

actual size

Quartz Crystal JTX110

- SMD Tuning Fork Crystal • 1.6 x 1.0 mm
- 32.768 kHz
- package height 0.5 mm max.



RoHS compliant



Pb free



REACH compliant



Conflict mineral free

GENERAL DATA	
TYPE	JTX110
frequency	32.768 kHz
frequency tolerance at 25 °C ± 5 °C	± 20 ppm
load capacitance C_L	12.5 pF std. / 10 pF / 9 pF / 7 pF / 6 pF
temperature constant (T_C)	$T_C = -0.04 \text{ ppm} / ^\circ\text{C}^2 \text{ max.}$ $T_C = -0.034 \text{ ppm} / ^\circ\text{C}^2 \text{ typical}$
frequency temperature characteristic	$\Delta f = T_C \cdot (T_A - T_{TP})^2 \text{ in [ppm]}$ $T_A = \text{actual ambient temperature}$ $T_{TP} = 25 \text{ }^\circ\text{C} \pm 5 \text{ }^\circ\text{C}$ $T_{TP} = \text{turning point temperature}$
operating temperature range	-20 °C ~ +70 °C ~ -40 °C ~ +105 °C
shunt capacitance C_0	1.3 pF typical
series resistance typ. (ESR)	70 kΩ at +25 °C
series resistance max. (ESR)	80 kΩ / 90 kΩ (for T1) / 110 kΩ (for T2)
storage temperature	-40 °C ~ +105 °C
drive level max.	0.5 μW
aging first year	< ± 3 ppm

TABLE 1: FREQUENCY STABILITY VS. TEMPERATURE				
frequency stability		-80 ppm	-160 ppm	-250 ppm
-20 °C ~ +70 °C	STD.	●		
-40 °C ~ +85 °C	T1		●	
-40 °C ~ +105 °C	T2			●

● available

MARKING

internal code / CL code / datecode
 date code = YWW
 Y = year
 WW = week

CL code:
 A = 12.5pF
 B = 9pF
 C = 7pF
 D = 6pF

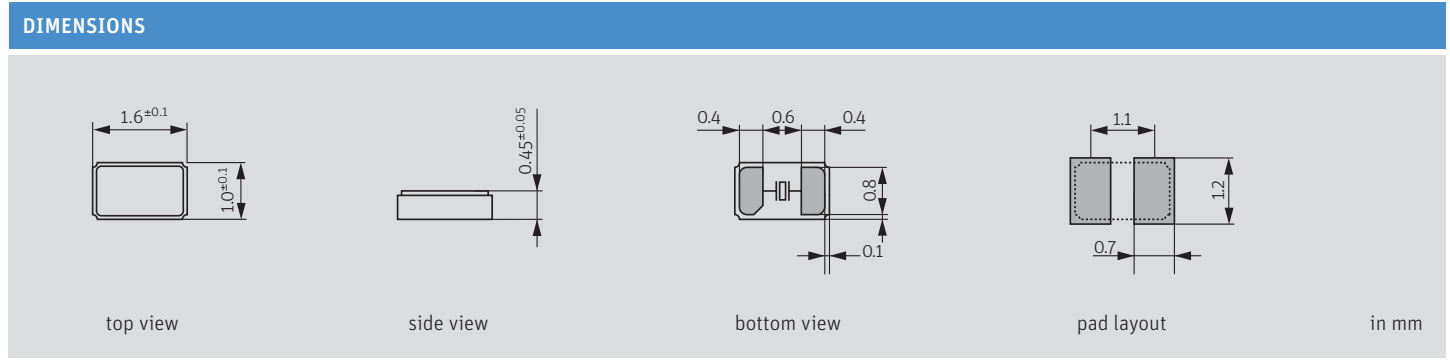

ORDER INFORMATION

Q	frequency	type	load capacitance	tolerance at 25 °C	temperature range options	ESR option
Quartz	0.032768 MHz	JTX110	12.5 pF standard 10 pF 9 pF 7 pF 6 pF	20 = ±20 ppm	blank = -20 °C ~ +70 °C T1 = -40 °C ~ +85 °C T2 = -40 °C ~ +105 °C	blank = 80 kΩ 90k = 90 kΩ 110k = 110 kΩ (for T2)

Example: Q 0.032768-JTX110-12.5-20-T1-90k-LF (Suffix LF = RoHS compliant / Pb free)

Quartz Crystal JTX110

FREQUENCY ERROR VS. TEMPERATURE IN PPM OR SECONDS PER DAY

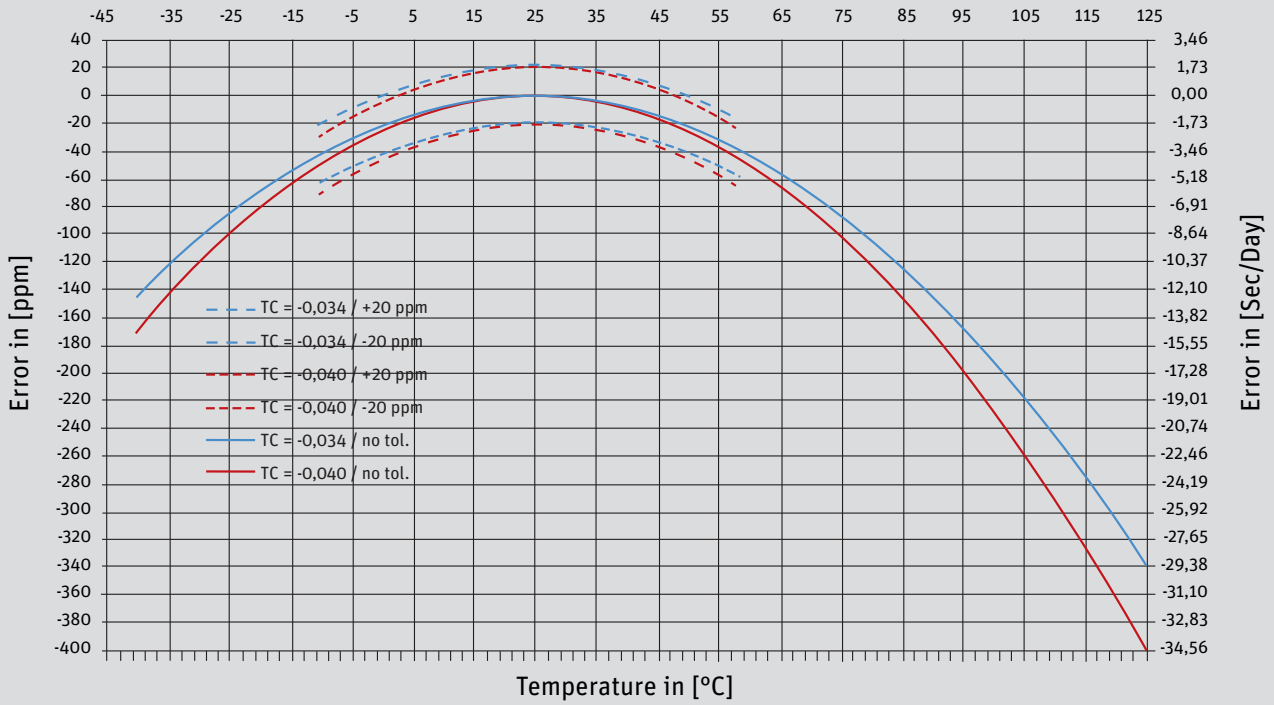

TAPING SPECIFICATION

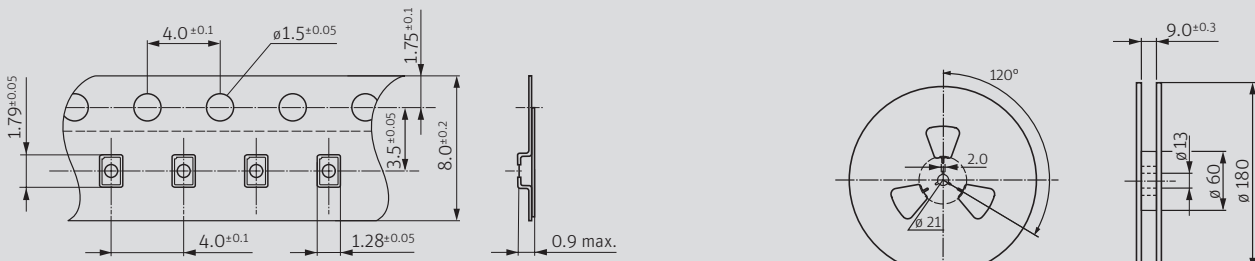

3000 pcs per reel (standard)
1000 pcs per reel (on request)

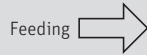

in mm

REFLOW SOLDERING PROFILE

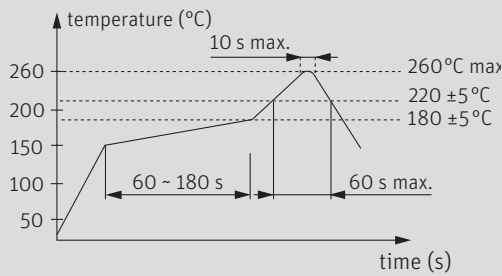

note: parts are also suitable for soldering systems with lead (Pb) content