

SnapN
50 Ω STRAIGHT PLUG

53QS101-272B5

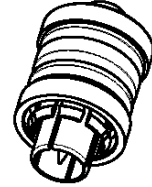
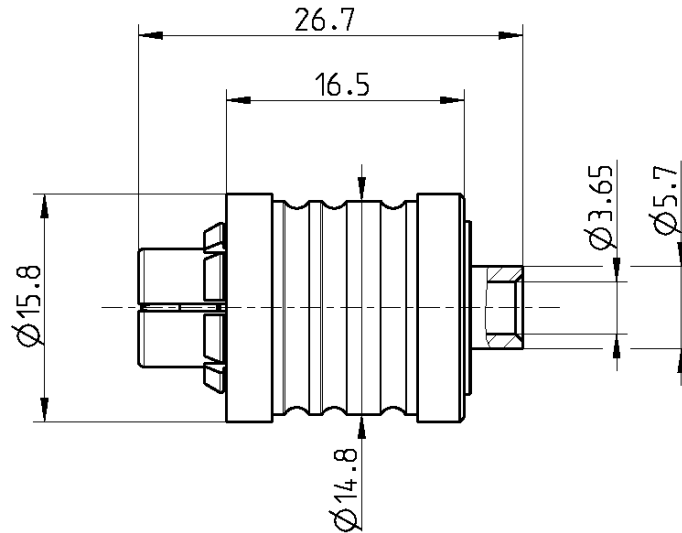

All dimensions are in mm; tolerances according to ISO 2768 m-H

Interface

Compatible to IEC 60169-16, MIL-PRF-39012, CECC 22210

Documents

Assembly instruction 53 T14

Material and plating

Connector parts	Material	Plating
Center contact	Brass	Auro Dur, gold plated
Outer contact	Brass	Silver, 3-6 μm
Body	Brass	Silver, 3-6 μm
Dielectric	PTFE	
Crimping ferrule	N/A	N/A

SnapN
50 Ω STRAIGHT PLUG

53QS101-272B5

Electrical data

Impedance	50 Ω
Frequency	DC to 11 GHz
Return loss	≥ 35 dB, DC to 2.5 GHz ≥ 23 dB, 2.5 to 8 GHz
Insertion loss	≤ 0.05 dB x √ f [GHz]
Insulation resistance	≥ 5 x10 ³ MΩ
Center contact resistance	≤ 1.0 mΩ
Outer contact resistance	≤ 1.0 mΩ
Test voltage	2500 V rms
Working voltage	1400 V rms
RF-leakage	≤ -90 dB, 100 MHz to 3 GHz ≤ -80 dB, 3 GHz to 6 GHz
Intermodulation (3 rd order)	≤ -155 dBc @ 1.8 GHz (2 x 43 dBm)

- Limitations are possible due to the used cable type -

Mechanical data

Mating cycles	min. 200
Engagement force	30 N (typ.)
Disengagement force	30 N (typ.)

Please always use the latching sleeve for locking and unlocking units

Environmental data

Temperature range	-40°C to +125°C
Thermal shock	MIL-STD-202, Meth. 107, Cond. B
Corrosion	MIL-STD-202, Meth. 101, Cond. B
Vibration	MIL-STD-202, Meth. 204, Cond. A
Shock	MIL-STD-202, Meth. 213, Cond. I
Moisture resistance 2002/95/EC (RoHS)	MIL-STD-202, Meth. 106 compliant

Tooling

Crimping tool	N/A
Crimp insert	N/A

Suitable cables

UT 141

Packing

Standard	50 pcs in bag
Weight	18.8 g/pce

While the information has been carefully compiled to the best of our knowledge, nothing is intended as representation or warranty on our part and no statement herein shall be construed as recommendation to infringe existing patents. In the effort to improve our products, we reserve the right to make changes judged to be necessary.

Draft	Date	Approved	Date	Rev.	Engineering change number	Name	Date
Andreas Fellner	17.03.05	A. Fellner	12/04/07	c00	07-0154	S. Huber-Siegl	12/04/07
Rosenberger Hochfrequenztechnik GmbH & Co. KG P.O.Box 1260 D-84526 Tittmoning Germany www.rosenberger.de						Tel.: +49 8684 18-0 Fax: +49 8684 18-499 email: info@rosenberger.de	
						Page 2 / 2	