

UM10664

PCA8885 and PCF8885 evaluation board OM11056

Rev. 1 — 29 January 2013

User manual

Document information

Info	Content
Keywords	Capacitive touch switch, touch sensor, proximity switch, PCF8885, PCA8885, OM11056, evaluation board, I ² C interface
Abstract	The OM11056 is a PCA8885 and PCF8885 evaluation board which can be used to demonstrate and evaluate the 8-channel capacitive touch and proximity switch. The PCB is designed to make it easy to adjust the switch's sensitivity. The board can be powered with 3.3 V or 5 V and the communication will be made through the I ² C interface.



Revision history

Rev	Date	Description
1	20130129	New user manual, first revision

Contact information

For more information, please visit: <http://www.nxp.com>

For sales office addresses, please send an email to: salesaddresses@nxp.com

1. Introduction

The PCx8885 is a capacitive touch and proximity sensor with 8 sensor channels. In order to help customers to evaluate NXP’s sensor technology and help to optimize their sensor structures, this evaluation board OM11056 has been designed.

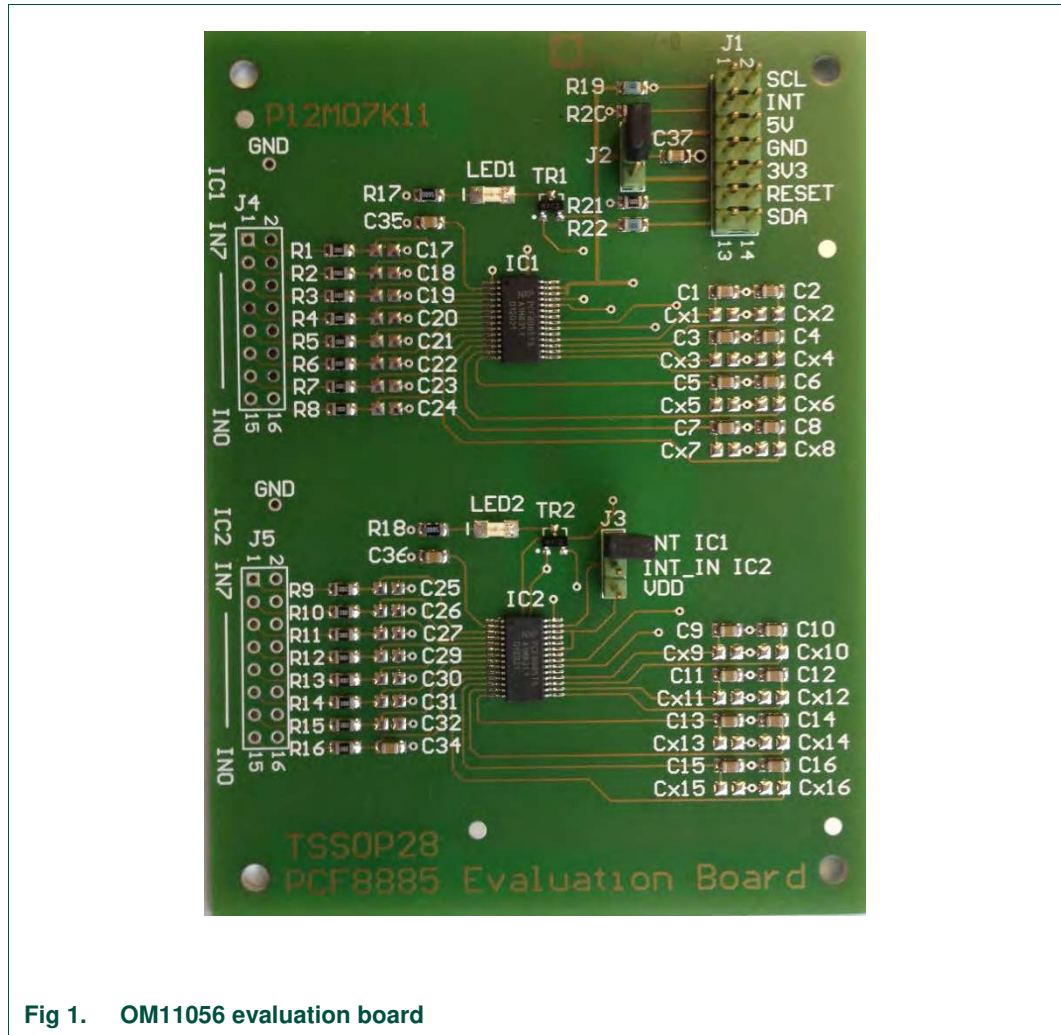

Fig 1. OM11056 evaluation board

1.1 Key features

1. PCB with two PCF8885 packages
2. Sensitivity for each channel can be set individually
3. LEDs to indicate channel activated
4. I²C interface

1.1.1 Schematics

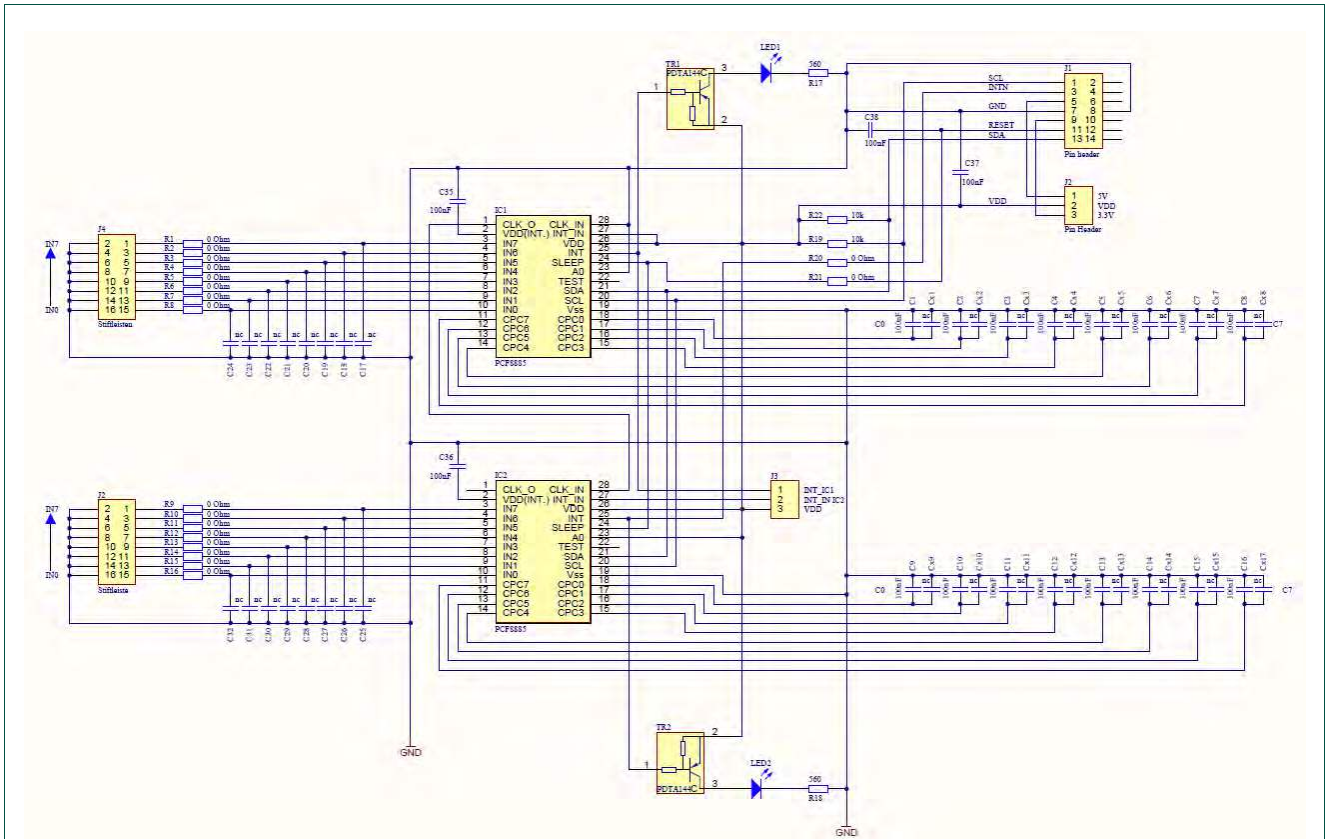

Fig 2. Schematic board layout

1.1.2 I²C interface and supply voltage

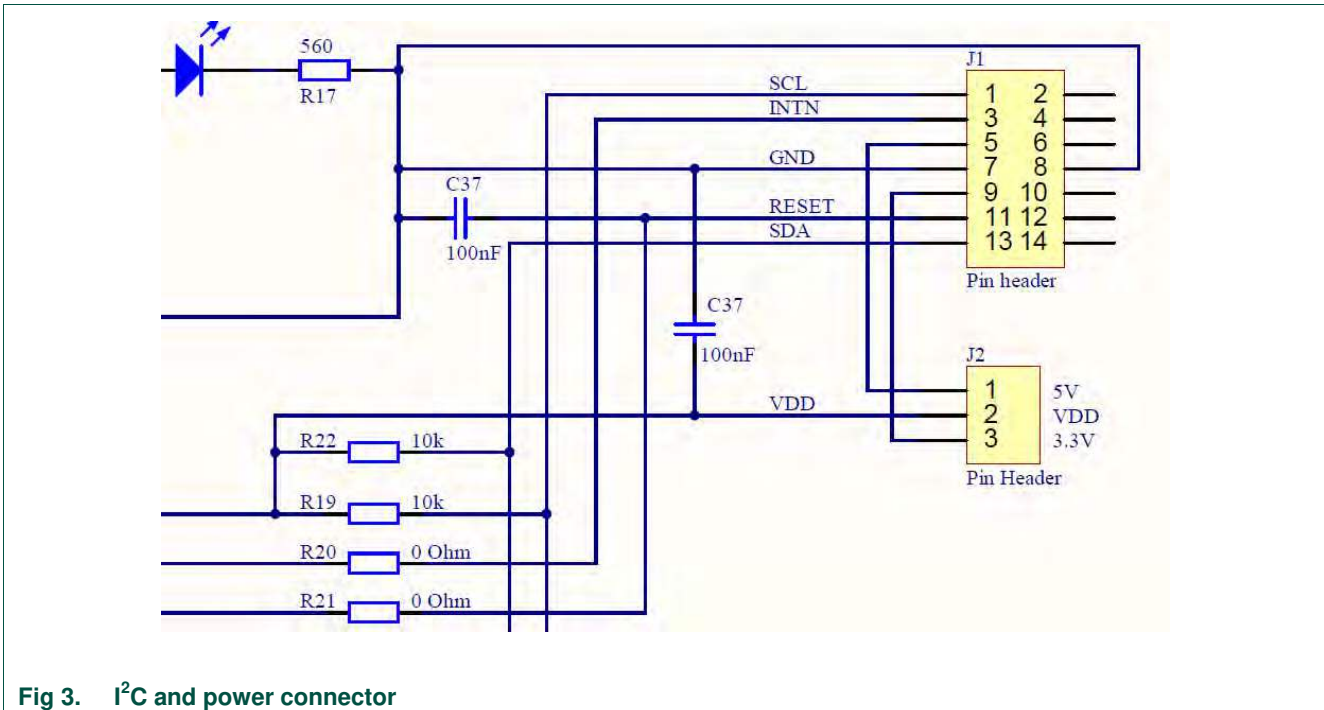

Fig 3. I²C and power connector

Table 1. J1 pin description

Pin	Description
1	I ² C, clock line
3	INT_N, Interrupt output from sensor ICs
5	Supply voltage 5 V
7, 8	GND
9	Supply voltage 3.3 V
11	RESET, this pin is wired to the SLEEP pin of the sensor ICs
13	I ² C, data line
2,4,6, 10, 12, 14	Not used

J2 allows use of two different supply sources.

1.1.3 Cascading two sensor ICs

Two PCF8885 packages can be cascaded to drive either an 8 x 8 matrix key pad or 16 simple touch keys. Cascading means that the sampling clock from the primary IC is fed into the secondary IC for synchronized sampling and the INT_N signals are ORed through the secondary IC. The primary IC will sample at the rising edge of the clock and the secondary IC on the falling edge of the clock. A high sampling rate can be maintained.

A jumper has to be inserted on J3, (pin1-2) to connect the INT_N signal from the primary IC to the secondary IC.

For single chip configuration pin2 should be connected to VDD (pin2-3).

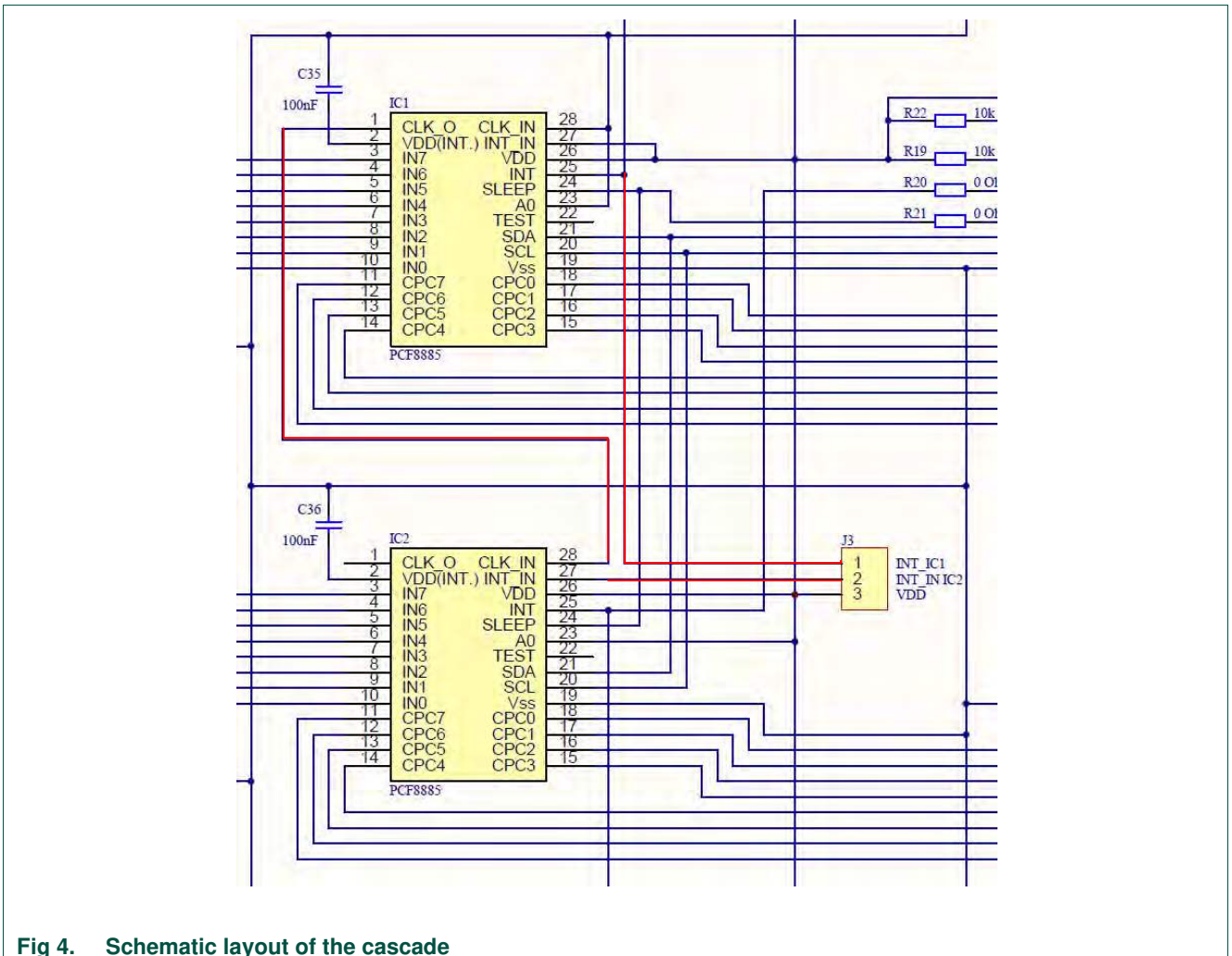

Fig 4. Schematic layout of the cascade

1.1.4 Sensor inputs and sensitivity

Capacitive loads through the entire specification range can be connected to the sensor inputs for the two ICs on the board. For capacitive loads beyond the specification (> 40 pF), resistors can be mounted in parallel to the sensor input to help the auto-calibration mechanism. In the latter case, the resistor value can start from 100 kOhm and down till optimal operation is obtained.

For applications where remote sensor pads are exposed to RF noise, low-pass filters can be built by using the resistors in series (R1 to R8) and the capacitors in parallel (C17 to C24).

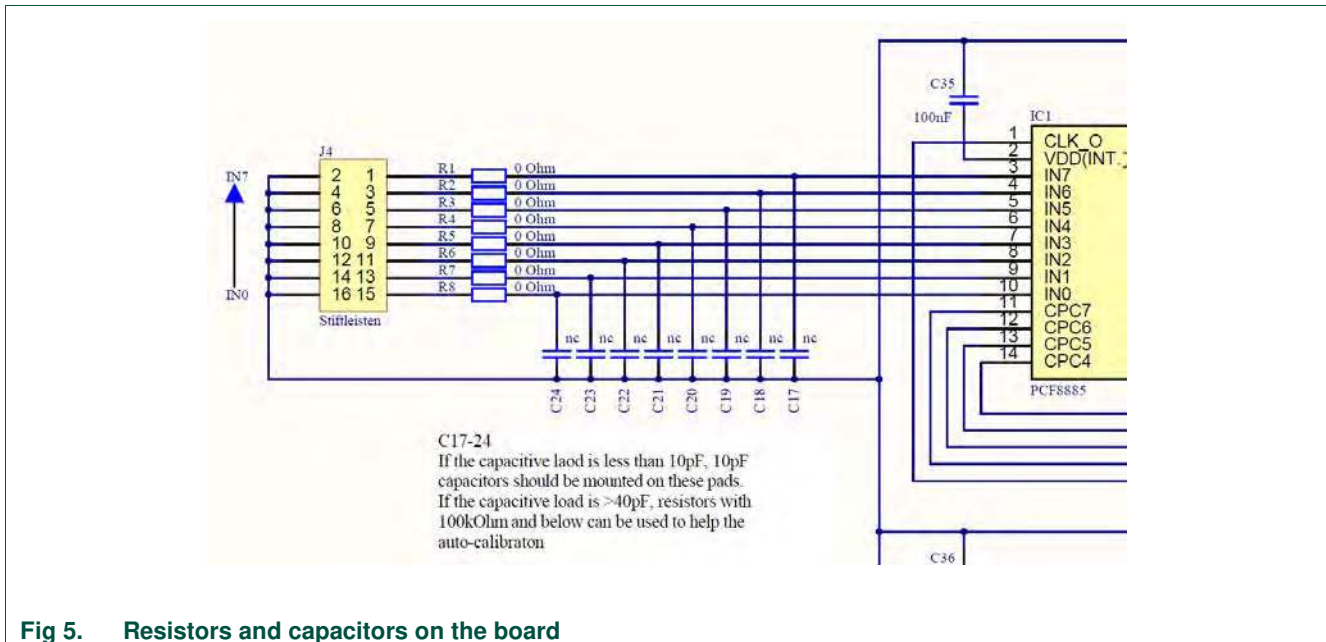

Fig 5. Resistors and capacitors on the board

1.1.5 Setting the sensitivity

The sensitivity is proportional to the CPC capacitor value for each channel. Default capacitance is 100 nF and there are additional pads for capacitors in parallel in case higher sensitivity is required. The CPC capacitors are specified in the range of 100 nF to 470 nF in the datasheet. These limits are only indicative, expected to cover entire range for sensitivity. Based on the size of the sensor pads and surrounding conductors, the CPC capacitance range can be extended both in lower and higher limits to 20 nF to 800 nF.

2. Legal information

2.1 Definitions

Draft — The document is a draft version only. The content is still under internal review and subject to formal approval, which may result in modifications or additions. NXP Semiconductors does not give any representations or warranties as to the accuracy or completeness of information included herein and shall have no liability for the consequences of use of such information.

2.2 Disclaimers

Limited warranty and liability — Information in this document is believed to be accurate and reliable. However, NXP Semiconductors does not give any representations or warranties, expressed or implied, as to the accuracy or completeness of such information and shall have no liability for the consequences of use of such information.

In no event shall NXP Semiconductors be liable for any indirect, incidental, punitive, special or consequential damages (including - without limitation - lost profits, lost savings, business interruption, costs related to the removal or replacement of any products or rework charges) whether or not such damages are based on tort (including negligence), warranty, breach of contract or any other legal theory.

Notwithstanding any damages that customer might incur for any reason whatsoever, NXP Semiconductors' aggregate and cumulative liability towards customer for the products described herein shall be limited in accordance with the Terms and conditions of commercial sale of NXP Semiconductors.

Right to make changes — NXP Semiconductors reserves the right to make changes to information published in this document, including without limitation specifications and product descriptions, at any time and without notice. This document supersedes and replaces all information supplied prior to the publication hereof.

Suitability for use — NXP Semiconductors products are not designed, authorized or warranted to be suitable for use in life support, life-critical or safety-critical systems or equipment, nor in applications where failure or malfunction of an NXP Semiconductors product can reasonably be expected to result in personal injury, death or severe property or environmental damage. NXP Semiconductors accepts no liability for inclusion and/or use of NXP Semiconductors products in such equipment or applications and therefore such inclusion and/or use is at the customer's own risk.

Applications — Applications that are described herein for any of these products are for illustrative purposes only. NXP Semiconductors makes no representation or warranty that such applications will be suitable for the specified use without further testing or modification.

Customers are responsible for the design and operation of their applications and products using NXP Semiconductors products, and NXP Semiconductors accepts no liability for any assistance with applications or customer product design. It is customer's sole responsibility to determine whether the NXP Semiconductors product is suitable and fit for the

customer's applications and products planned, as well as for the planned application and use of customer's third party customer(s). Customers should provide appropriate design and operating safeguards to minimize the risks associated with their applications and products.

NXP Semiconductors does not accept any liability related to any default, damage, costs or problem which is based on any weakness or default in the customer's applications or products, or the application or use by customer's third party customer(s). Customer is responsible for doing all necessary testing for the customer's applications and products using NXP Semiconductors products in order to avoid a default of the applications and the products or of the application or use by customer's third party customer(s). NXP does not accept any liability in this respect.

Export control — This document as well as the item(s) described herein may be subject to export control regulations. Export might require a prior authorization from competent authorities.

Evaluation products — This product is provided on an "as is" and "with all faults" basis for evaluation purposes only. NXP Semiconductors, its affiliates and their suppliers expressly disclaim all warranties, whether express, implied or statutory, including but not limited to the implied warranties of non-infringement, merchantability and fitness for a particular purpose. The entire risk as to the quality, or arising out of the use or performance, of this product remains with customer.

In no event shall NXP Semiconductors, its affiliates or their suppliers be liable to customer for any special, indirect, consequential, punitive or incidental damages (including without limitation damages for loss of business, business interruption, loss of use, loss of data or information, and the like) arising out of the use of or inability to use the product, whether or not based on tort (including negligence), strict liability, breach of contract, breach of warranty or any other theory, even if advised of the possibility of such damages.

Notwithstanding any damages that customer might incur for any reason whatsoever (including without limitation, all damages referenced above and all direct or general damages), the entire liability of NXP Semiconductors, its affiliates and their suppliers and customer's exclusive remedy for all of the foregoing shall be limited to actual damages incurred by customer based on reasonable reliance up to the greater of the amount actually paid by customer for the product or five dollars (US\$5.00). The foregoing limitations, exclusions and disclaimers shall apply to the maximum extent permitted by applicable law, even if any remedy fails of its essential purpose.

Translations — A non-English (translated) version of a document is for reference only. The English version shall prevail in case of any discrepancy between the translated and English versions.

2.3 Trademarks

Notice: All referenced brands, product names, service names and trademarks are property of their respective owners.

3. List of figures

Fig 1.	OM11056 evaluation board.....	3
Fig 2.	Schematic board layout.....	4
Fig 3.	I ² C and power connector.....	5
Fig 4.	Schematic layout of the cascade	6
Fig 5.	Resistors and capacitors on the board.....	7

4. List of tables

Table 1. J1 pin description5

5. Contents

1.	Introduction	3	2.1	Definitions.....	8
1.1	Key features	3	2.2	Disclaimers.....	8
1.1.1	Schematics.....	4	2.3	Trademarks	8
1.1.2	I ² C interface and supply voltage.....	5	3.	List of figures.....	9
1.1.3	Cascading two sensor ICs.....	6	4.	List of tables	10
1.1.4	Sensor inputs and sensitivity.....	7	5.	Contents	11
1.1.5	Setting the sensitivity	7			
2.	Legal information	8			

Please be aware that important notices concerning this document and the product(s) described herein, have been included in the section 'Legal information'.

© NXP B.V. 2013.

All rights reserved.

For more information, please visit: <http://www.nxp.com>
 For sales office addresses, please send an email to: salesaddresses@nxp.com

Date of release: 29 January 2013
 Document identifier: UM10664