



ANATECH ELECTRONICS INC
RF & Microwave Filters & Products

1000 MHz LC Band Pass Filter

Part Number: AE1000B6333



Electrical Specifications

Center Frequency: 1000 MHz
Passband: 750-1250 MHz
Insertion Loss: 2.0dB Max.
Return Loss: 14dB Min.
Rejection: $\geq 68\text{dB}$ @ 583 MHz
Rejection2: $\geq 60\text{dB}$ @ 1416 MHz

Mechanical

Mounting Method: Through Holes
Connector Type: SMA(F)
Dimensions: 4.0" X 1.25" x 0.75" .

Environmental

Operating Temperature: -25°C to +70°C
Storage Temperature: -40°C to +90°C
Shock: 10 G. 11ms
Vibration: 10 G. 5 to 200Hz

Outline Drawing:

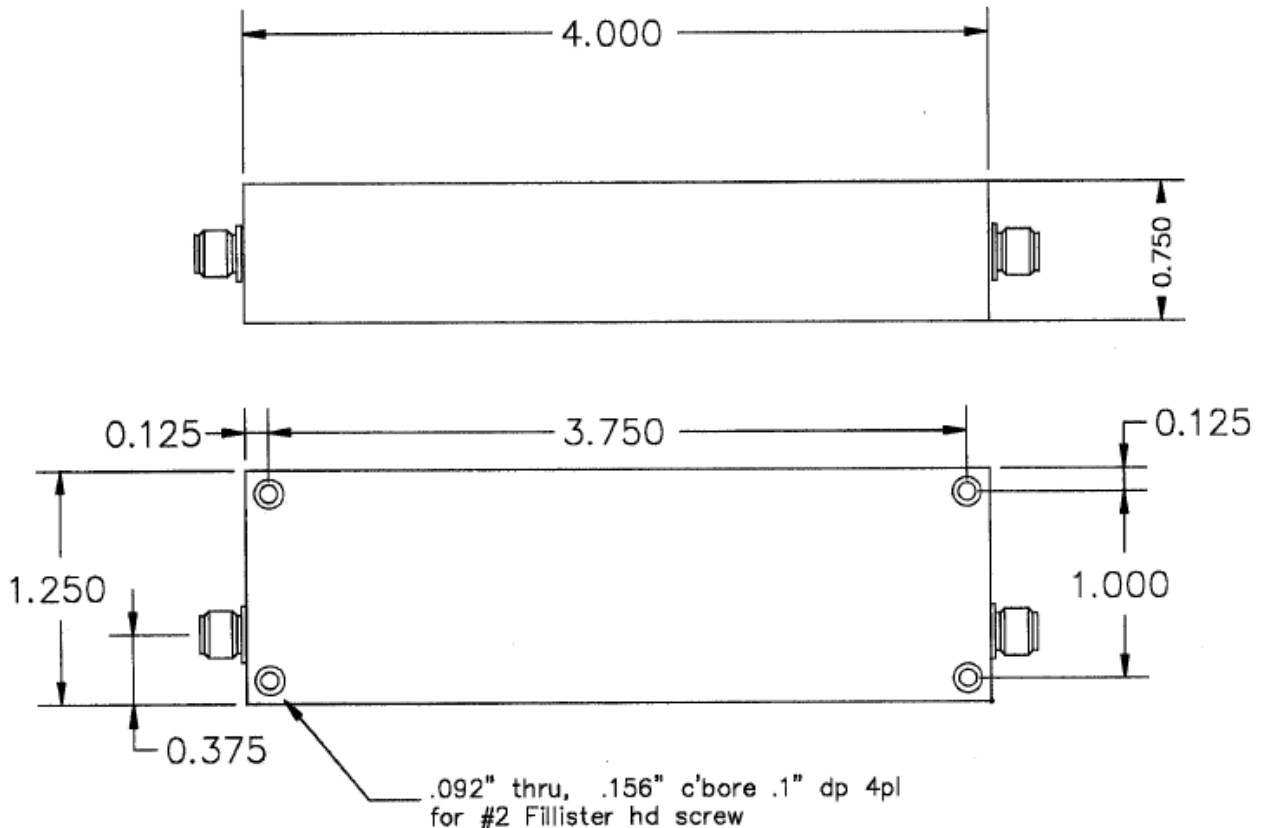



ANATECH ELECTRONICS INC
RF & Microwave Filters & Products

1000 MHz LC Band Pass Filter

Part Number: AE1000B6333



Response Plot:

