



MADE IN THE USA

### Product Description:

- Glove Box Dispenser - Single with Flexible Spring
- Holds one box of gloves
- Two-way keyholes for vertical or horizontal wall mounting
- White Sintra® Plastic

### Primary Area for Product Usage:

- Anywhere glove boxes are needed

### Dispenses:

- Box(es) no larger than 5.50"W x 11.00"H x 3.75"D (14.0 cm x 27.9 cm x 9.5 cm)
- Box(es) no smaller than 3.75"W x 8.00"H x 3.00"D (9.5 cm x 20.3 cm x 7.6 cm)

### Package Specifications:

- Package Quantity: 12 per case
- 18"L x 16"W x 10"H (45.7 cm x 40.6 cm x 25.4 cm)
- 9.0 lbs (4.1 kg) - approximated

### Product Specifications (overall external dimensions):

- 5.80"W x 10.06"H x 4.07"D (14.7 cm x 25.6 cm x 10.3 cm)
- 0.5 lbs (0.2 kg) - approximated

### Mounting Specifications:

### Related Products (each sold separately):

- GB-001: Glove Box Dispenser - Single with Flexible Spring, Powder-Coated Steel (shown below)

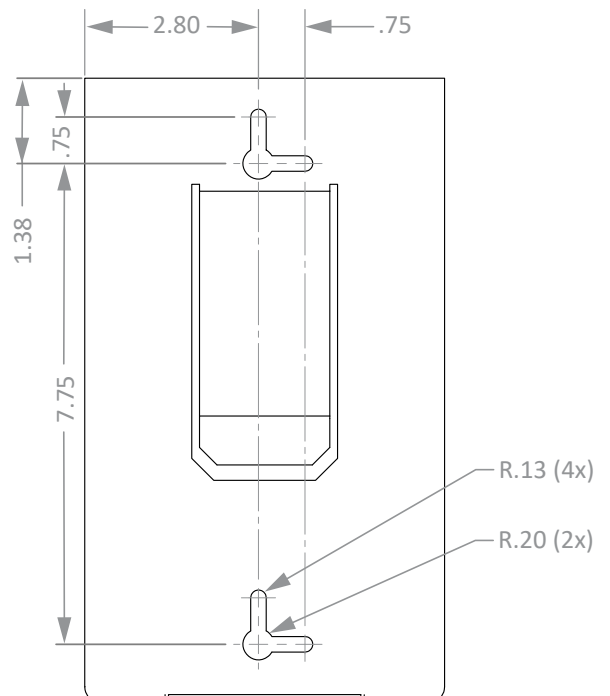



## Installation

Always mount dispensers securely *prior* to loading with product.

- Built-in flexible spring holes boxes securely even as supply diminishes.

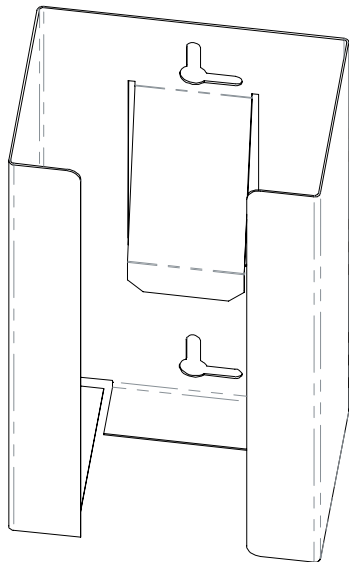

- Mount securely to a wall with screws approved and supplied by building maintenance.

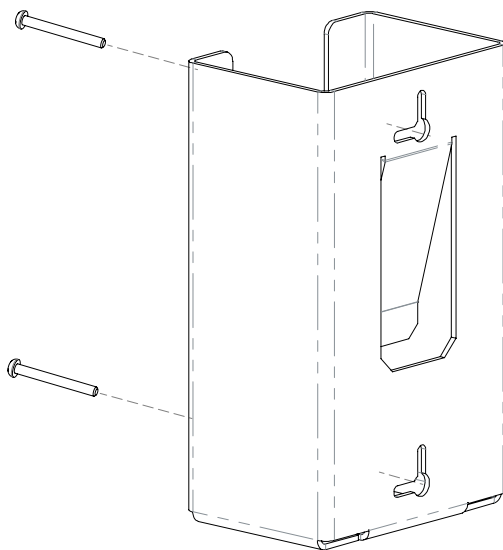

### Parts included:

- Dispenser

### Tools Required:

- No tools required to assemble dispenser

## Care and Construction

Sintra® Plastic

### Material Characteristics

### Designed for Long-Term Applications

Sintra® plastic is a lightweight, yet rigid, board of moderately expanded closed-cell polyvinyl chloride (PVC). It is dent resistant and provides an excellent combination of rigidity and durability.

Sintra® has a high strength-to-weight ratio and offers excellent corrosion, dent, and scratch resistance. It's resistance to moisture makes it an excellent choice for locations prone to high humidity. Products constructed of Sintra® should not be located in areas subject to high temperatures (above 140° F).

The surface of Sintra® has a low gloss, matte finish.

### Care and Cleaning

Sintra® can be wiped clean with a mild cleaner or soap and lukewarm water. Isopropyl alcohol is recommended to remove grease or oil. Ammonia and acetone should not be used.

Standard hospital cleaning supplies are approved for use on our Sintra® products.