

Amphenol

Advanced Sensors

THERMISTOR SPECIFICATION NTC THERMISTOR TYPE: A-1217	Originated by: S. Schneider THM Ref. No. 14425800	PAGE 1 of 1 DATE: 05/09/2019
CUSTOMER: N/A	CUSTOMER SPECIFICATION No. N/A	

DESCRIPTION: 1/8" NPTF Brass Temperature Sensor

ELECTRICAL SPECIFICATION

Resistance specification:
 402,392Ω ± 12.42% @ -40°C (352,415Ω - 452,369Ω)
 11,150Ω ± 7.45% @ 25°C (10,319Ω - 11,981Ω)
 710.2Ω ± 3.85% @ 100°C (682.8Ω - 737.5Ω)
 150.6Ω ± 2.60% @ 160°C (146.7Ω - 154.5Ω)

MECHANICAL SPECIFICATION

Connector: 2 Pin Metri-Pack 150 Unsealed, Nylon 66 – Black
 Mating Connector: Aptiv (Delphi) 12047662
 Installation Torque: 6.0-9.0 N·m REF dynamic
 Sensor must be hand started into threaded hole 1/8:-27 PTF or PSF
 Max installation speed using an pneumatic driver: 400 RPM REF no load speed.

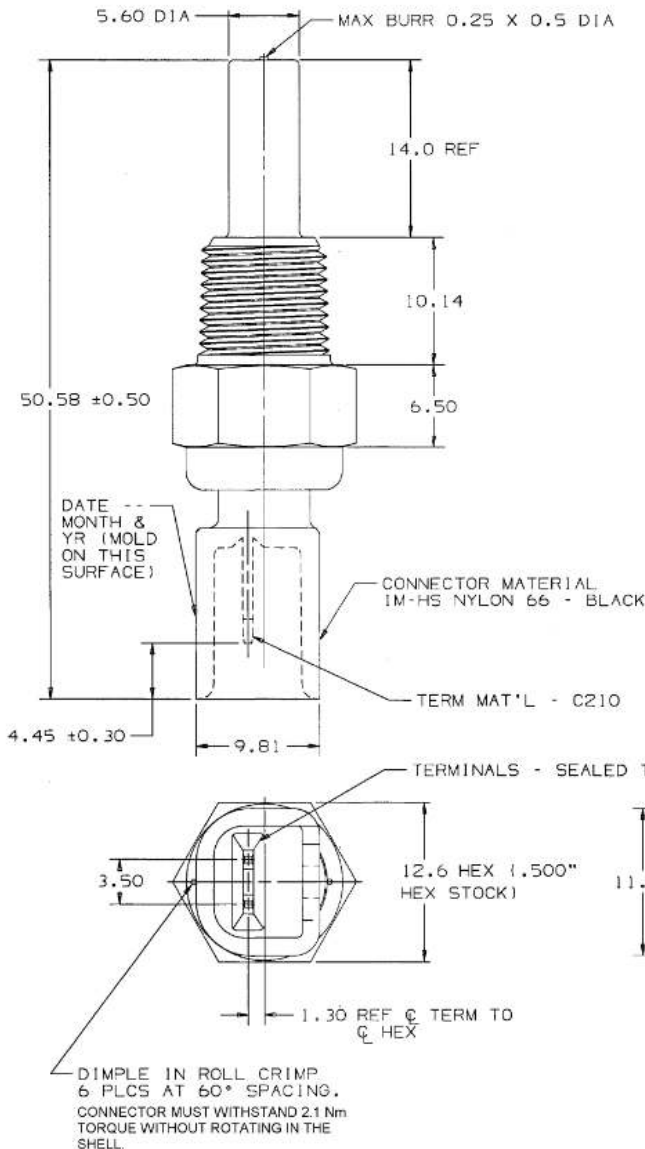

Dimensions are in millimeters
(not to scale)

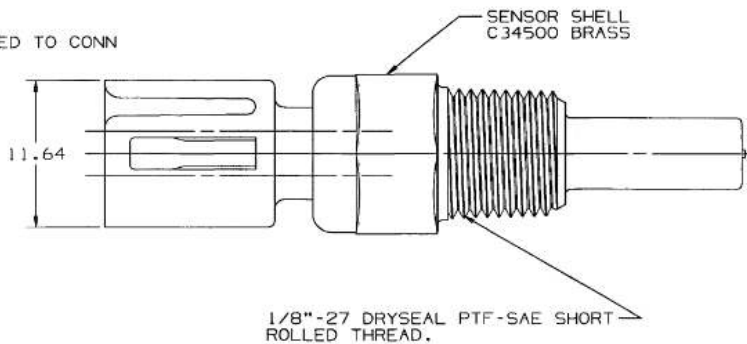

967 WINDFALL RD, ST MARYS, PA 15857 Ph (814) 834-9140 Fx (814) 781-7969