

FEATURES**44 V supply maximum ratings** **V_{SS} to V_{DD} analog signal range****Low on resistance (12 Ω typ)****Low ΔR_{ON} (3 Ω max)****Low R_{ON} match (2.5 Ω max)****Low power dissipation****Fast switching times** **$t_{ON} < 175$ ns** **$t_{OFF} < 145$ ns****Low leakage currents (5 nA max)****Low charge injection (10 pC)****Break-before-make switching action****APPLICATIONS****Audio and video switching****Battery-powered systems****Test equipment****Communications systems****GENERAL DESCRIPTION**

The ADG436 is a monolithic CMOS device comprising two independently selectable SPDT switches. It is designed on an LC²MOS process, which provides low power dissipation yet gives high switching speed and low on resistance.

The on resistance profile is very flat over the full analog input range, ensuring good linearity and low distortion when switching audio signals. High switching speed also makes the part suitable for video signal switching. CMOS construction ensures ultralow power dissipation, making the part ideally suited for portable and battery-powered instruments.

Each switch conducts equally well in both directions when on and has an input signal range which extends to the power supplies. In the off condition, signal levels up to the supplies are blocked. All switches exhibit break-before-make switching action for use in multiplexer applications. Inherent in the design is low charge injection for minimum transients when switching the digital inputs.

Rev. B

Information furnished by Analog Devices is believed to be accurate and reliable. However, no responsibility is assumed by Analog Devices for its use, nor for any infringements of patents or other rights of third parties that may result from its use. Specifications subject to change without notice. No license is granted by implication or otherwise under any patent or patent rights of Analog Devices. Trademarks and registered trademarks are the property of their respective owners.

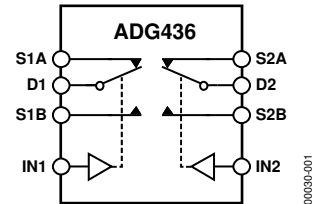
FUNCTIONAL BLOCK DIAGRAM*Figure 1.***PRODUCT HIGHLIGHTS**

1. Extended signal range.
The ADG436 is fabricated on an enhanced LC²MOS process, giving an increased signal range that extends to the supply rails.
2. Low power dissipation.
3. Low R_{ON} .
4. Single-supply operation.
For applications where the analog signal is unipolar, the ADG436 can be operated from a single rail power supply.

TABLE OF CONTENTS

Specifications.....	3	Typical Performance Characteristics	8
Dual Supply	3	Test Circuits.....	10
Single Supply	4	Applications Information	11
Absolute Maximum Ratings.....	5	ADG436 Supply Voltages	11
ESD Caution.....	5	Power-Supply Sequencing.....	11
Pin Configuration and Function Descriptions.....	6	Outline Dimensions	12
Terminology	7	Ordering Guide	12

REVISION HISTORY

3/05—Rev. A to Rev. B

Updated Format.....	Universal
Changes to Specifications Tables.....	3
Changes to Figure 11.....	8
Updated Outline Dimensions	12
Changes to Ordering Guide	12

11/98—Rev. 0 to Rev. A

1/96—Revision 0: Initial Version

SPECIFICATIONS

DUAL SUPPLY¹

$V_{DD} = +15\text{ V}$, $V_{SS} = -15\text{ V}$, $GND = 0\text{ V}$, unless otherwise noted.

Table 1.

Parameter	+25°C	-40°C to +85°C	Unit	Test Conditions/ Comments
ANALOG SWITCH				
Analog Signal Range		V_{SS} to V_{DD}	V	
R_{ON}	12		Ω typ Ω max	$V_D = \pm 10\text{ V}$, $I_S = -1\text{ mA}$
ΔR_{ON}	1	25	Ω typ Ω max	$V_D = -5\text{ V}$, 5 V , $I_S = -10\text{ mA}$
$R_{ONMatch}$	1	3	Ω typ Ω max	$V_D = \pm 10\text{ V}$, $I_S = -10\text{ mA}$
		2.5	Ω max	
LEAKAGE CURRENTS				
Source OFF Leakage I_S (OFF)	± 0.005		nA typ nA max	$V_{DD} = 16.5\text{ V}$, $V_{SS} = -16.5\text{ V}$ $V_D = \pm 15.5\text{ V}$, $V_S = \pm 15.5\text{ V}$ Figure 13
Channel ON Leakage I_D , I_S (ON)	± 0.05 ± 0.4	± 5 ± 5	nA typ nA max	$V_S = V_D = \pm 15.5\text{ V}$ Figure 14
DIGITAL INPUTS				
Input High Voltage, V_{INH}		2.4	V min	
Input Low Voltage, V_{INL}		0.8	V max	
Input Current, I_{INL} or I_{INH}		± 0.005 ± 0.5	μA typ μA max	$V_{IN} = 0\text{ V}$ or V_{DD}
DYNAMIC CHARACTERISTICS²				
t_{ON}	70		ns typ ns max	$R_L = 300\ \Omega$, $C_L = 35\text{ pF}$; $V_S = \pm 10\text{ V}$; Figure 15
t_{OFF}	60	125	ns typ ns max	$R_L = 300\ \Omega$, $C_L = 35\text{ pF}$; $V_S = \pm 10\text{ V}$; Figure 15
Break-Before-Make Delay, t_{OPEN}	10	120	ns max ns min	$R_L = 300\ \Omega$, $C_L = 35\text{ pF}$; $V_S = +5\text{ V}$; Figure 16
Charge Injection	10		pC typ	$V_D = 0\text{ V}$, $R_D = 0\ \Omega$, $C_L = 10\text{ nF}$; Figure 17
OFF Isolation	72		dB typ	$R_L = 75\ \Omega$, $C_L = 5\text{ pF}$, $f = 1\text{ MHz}$; $V_S = 2.3\text{ V rms}$, Figure 18
Channel-to-Channel Crosstalk	90		dB typ	$R_L = 75\ \Omega$, $C_L = 5\text{ pF}$, $f = 1\text{ MHz}$; $V_S = 2.3\text{ V rms}$, Figure 19
C_S (OFF)	13		pF typ	
C_D , C_S (ON)	49		pF typ	
POWER REQUIREMENTS				
I_{DD}	0.05		mA typ mA max	Digital inputs = 0 V or 5 V
I_{SS}	0.01	0.35	μA typ μA max	
V_{DD}/V_{SS}	1	5	V min/V max	$ V_{DD} = V_{SS} $
		$\pm 3/\pm 20$		

¹ Temperature range is as follows: B version, -40°C to $+85^\circ\text{C}$.

² Guaranteed by design; not subject to production test.

ADG436

SINGLE SUPPLY¹

$V_{DD} = 12\text{ V}$, $V_{SS} = 0\text{ V}$, $GND = 0\text{ V}$, unless otherwise noted.

Table 2.

Parameter	+25°C	−40°C to +85°C	Unit	Test Conditions/ Comments
ANALOG SWITCH				
Analog Signal Range		0 to V_{DD}	V	
R_{ON}	20	40	Ω typ	$V_D = 1\text{ V}$, 10 V, $I_S = -1\text{ mA}$
$R_{ONMatch}$		2.5	Ω max	
LEAKAGE CURRENTS				
Source OFF Leakage I_S (OFF)	± 0.005		nA typ	$V_{DD} = 13.2\text{ V}$ $V_D = 12.2\text{ V}/1\text{ V}$, $V_S = 1\text{ V}/12.2\text{ V}$
	± 0.25	± 5	nA max	Figure 13
Channel ON Leakage I_D , I_S (ON)	± 0.05		nA typ	$V_S = V_D = 12.2\text{ V}/1\text{ V}$
	± 4	± 5	nA max	Figure 14
DIGITAL INPUTS				
Input High Voltage, V_{INH}		2.4	V min	
Input Low Voltage, V_{INL}		0.8	V max	
Input Current, I_{INL} or I_{INH}		± 0.005	μA typ	$V_{IN} = 0\text{ V}$ or V_{DD}
		± 0.5	μA max	
DYNAMIC CHARACTERISTICS²				
t_{ON}	100	200	ns typ	$R_L = 300\ \Omega$, $C_L = 35\text{ pF}$;
			ns max	$V_S = 8\text{ V}$; Figure 15
t_{OFF}	90	180	ns typ	$R_L = 300\ \Omega$, $C_L = 35\text{ pF}$;
			ns max	$V_S = 8\text{ V}$; Figure 15
Break-Before-Make Delay, t_{OPEN}	10		ns typ	$R_L = 300\ \Omega$, $C_L = 35\text{ pF}$;
				$V_S = 5\text{ V}$; Figure 16
Charge Injection	10		pC typ	$V_D = 6\text{ V}$, $R_D = 0\ \Omega$, $C_L = 10\text{ nF}$; Figure 17
OFF Isolation	72		dB typ	$R_L = 75\ \Omega$, $C_L = 5\text{ pF}$, $f = 1\text{ MHz}$;
				$V_S = 1.15\text{ V rms}$; Figure 18
Channel-to-Channel Crosstalk	90		dB typ	$R_L = 75\ \Omega$, $C_L = 5\text{ pF}$, $f = 1\text{ MHz}$;
				$V_S = 1.15\text{ V rms}$, Figure 19
C_S (OFF)	22		pF typ	
C_D , C_S (ON)	46		pF typ	
POWER REQUIREMENTS				
I_{DD}	0.05	0.35	mA typ	$V_{DD} = 13.5\text{ V}$
			mA max	Digital inputs = 0 V or 5 V
V_{DD}		+3/+30	V min/V max	

¹ Temperature range is as follows: B version, -40°C to $+85^\circ\text{C}$.

² Guaranteed by design; not subject to production test.

ABSOLUTE MAXIMUM RATINGS

$T_A = 25^\circ\text{C}$ unless otherwise noted.

Table 3.

Parameter	Rating
V_{DD} to V_{SS}	+44 V
V_{DD} to GND	-0.3 V to +30 V
V_{SS} to GND	+0.3 V to -30 V
Analog, Digital Inputs ¹	$V_{SS} - 2\text{ V}$ to $V_{DD} + 2\text{ V}$ or 20 mA, whichever occurs first
Continuous Current, S or D	20 mA
Peak Current, S or D (pulsed at 1 ms, 10% Duty Cycle max)	40 mA
Operating Temperature Range Industrial (B Version)	-40°C to +85°C
Storage Temperature Range	-65°C to +125°C
Junction Temperature	150°C
θ_{JA} , Thermal Impedance	
PDIP Package	117°C/W
SOIC Package	77°C/W
Lead Temperature, Soldering (10 sec)	260°C
Lead Temperature, Soldering	
Vapor Phase (60 sec)	215°C
Infrared (15 sec)	220°C

¹ Overvoltages at IN, S, or D are clamped by internal diodes. Current should be limited to the maximum ratings given.

Stresses above those listed under Absolute Maximum Ratings may cause permanent damage to the device. This is a stress rating only; functional operation of the device at these or any other conditions above those listed in the operational sections of this specification is not implied. Exposure to absolute maximum rating conditions for extended periods may affect device reliability. Only one absolute maximum rating may be applied at any one time.

Table 4. Truth Table

Logic	Switch A	Switch B
0	Off	On
1	On	Off

ESD CAUTION

ESD (electrostatic discharge) sensitive device. Electrostatic charges as high as 4000 V readily accumulate on the human body and test equipment and can discharge without detection. Although this product features proprietary ESD protection circuitry, permanent damage may occur on devices subjected to high energy electrostatic discharges. Therefore, proper ESD precautions are recommended to avoid performance degradation or loss of functionality.



ADG436

PIN CONFIGURATION AND FUNCTION DESCRIPTIONS

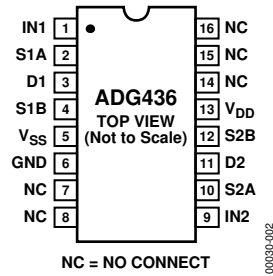

Figure 2. Pin Configuration

Table 5. Pin Function Descriptions

Pin No.	Mnemonic	Descriptions
1, 9	IN1, IN2	Logic Control Input.
2, 4, 10, 12	S1A, S1B, S2A, S2B	Source Terminal. Can be an input or output.
3, 11		Drain Terminal. C be an input or output.
5	V _{SS}	Most Negative Power Supply Potential in Dual Supplies. In single-supply applications, it can be connected to ground.
6	GND	Ground (0 V) Reference.
7, 8, 14, 15, 16	NC	No Connect.
13	V _{DD}	Most Positive Power Supply Potential.

TERMINOLOGY

Table 6.

Mnemonic	Descriptions
R_{ON}	Ohmic resistance between D and S.
ΔR_{ON}	R_{ON} variation due to a change in the analog input voltage with a constant load current.
$R_{ONMatch}$	Difference between the R_{ON} of any two channels.
I_S (OFF)	Source leakage current with the switch off.
I_D, I_S (ON)	Channel leakage current with the switch on.
V_D (V_S)	Analog voltage on terminals D, S.
C_S (OFF)	OFF switch source capacitance.
C_D, C_S (ON)	ON switch capacitance.
t_{ON}	Delay between applying the digital control input and the output switching on.
t_{OFF}	Delay between applying the digital control input and the output switching off.
t_{OPEN}	Break-before-make delay when switches are configured as a multiplexer.
V_{INL}	Maximum input voltage for Logic 0.
V_{INH}	Minimum input voltage for Logic 1.
I_{INL} (I_{INH})	Input current of the digital input.
Crosstalk	A measure of unwanted signal that is coupled through from one channel to another as a result of parasitic capacitance.
Off Isolation	A measure of unwanted signal coupling through an OFF switch.
Charge Injection	A measure of the glitch impulse transferred from the digital input to the analog output during switching.
I_{DD}	Positive supply current.
I_{SS}	Negative supply current.

TYPICAL PERFORMANCE CHARACTERISTICS

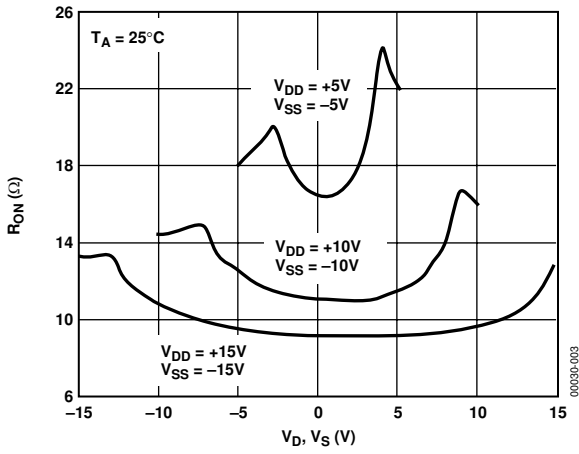

Figure 3. R_{ON} as a Function of $V_D (V_S)$: Dual Supply

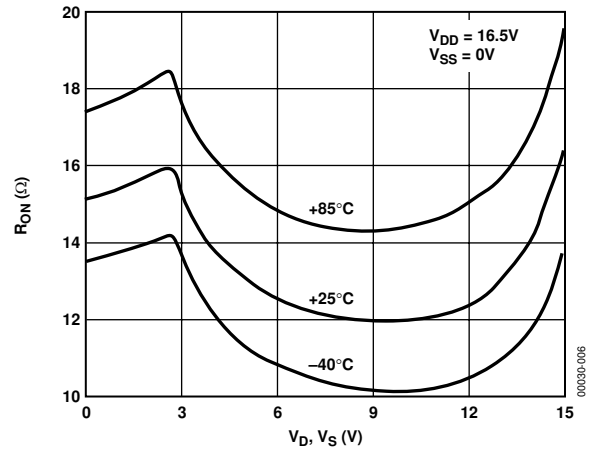

Figure 6. R_{ON} as a Function of $V_D (V_S)$ for Different Temperatures: Single Supply

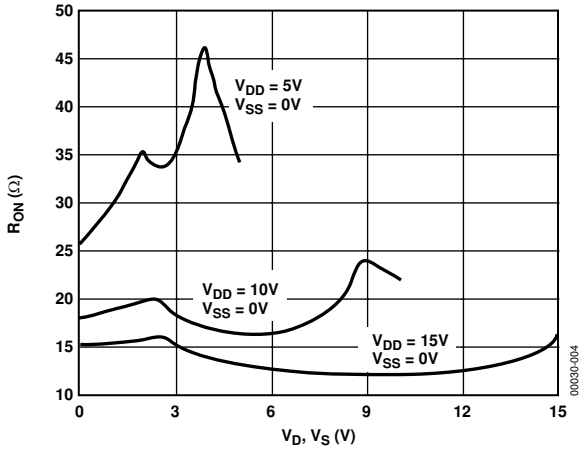

Figure 4. R_{ON} as a Function of $V_D (V_S)$: Single Power Supply

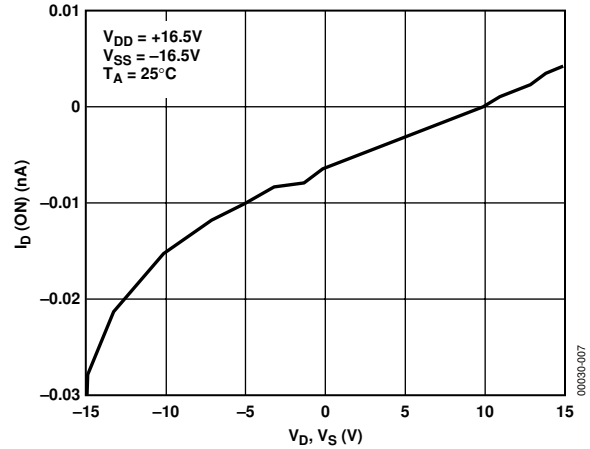

Figure 7. I_D (ON) Leakage Current as a Function of $V_D (V_S)$: Dual Supply

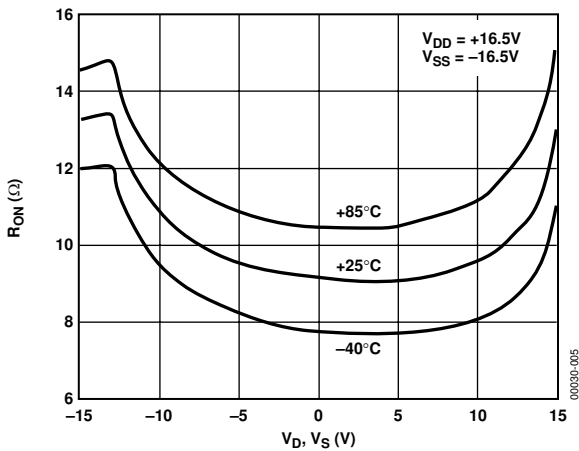

Figure 5. R_{ON} as a Function of $V_D (V_S)$ for Different Temperatures: Dual Supply

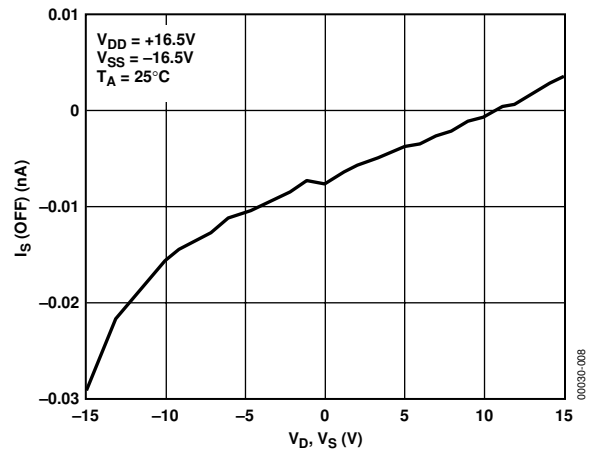

Figure 8. I_S (OFF) Leakage Current as a Function of $V_D (V_S)$: Dual Supply

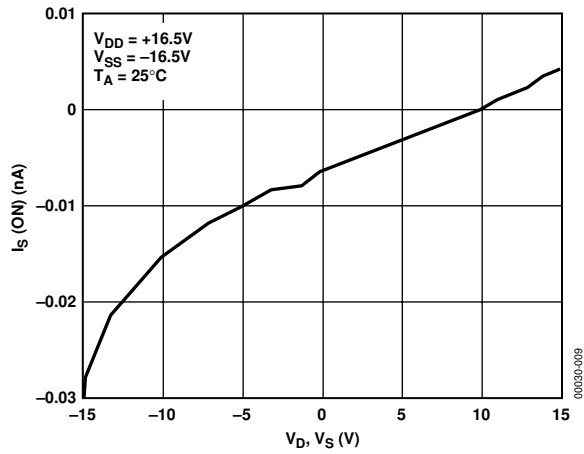

Figure 9. I_S (ON) Leakage Current as a Function of V_D (V_S): Dual Supply

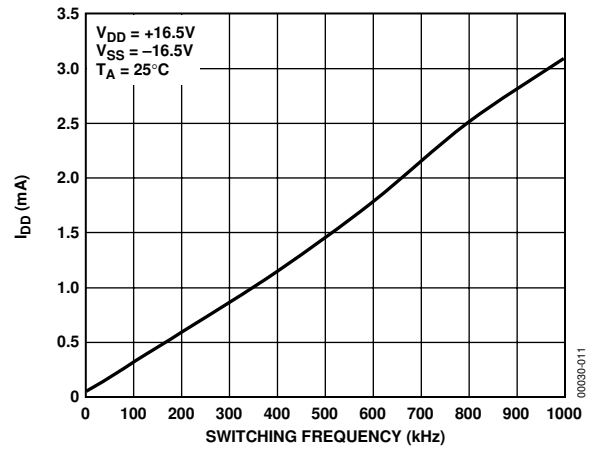

Figure 11. I_{DD} as a Function of Switching Frequency: Dual Supply

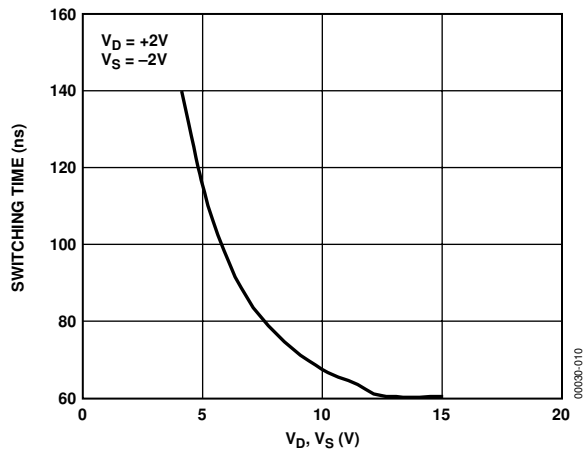

Figure 10. Switching Time as a Function of V_D (V_S): Dual Supply

TEST CIRCUITS

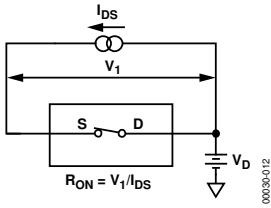

Figure 12. On Resistance

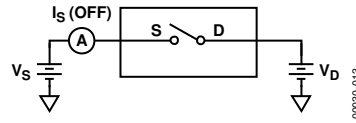

Figure 13. Off Leakage

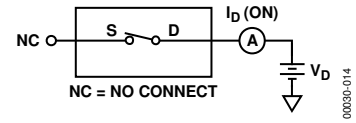

Figure 14. On Leakage

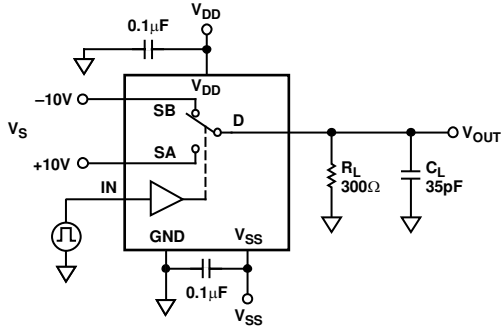

Figure 15. Switching Times

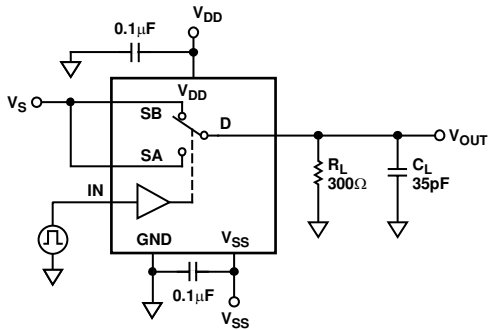

Figure 16. Break-Before-Make Delay, t_{open}

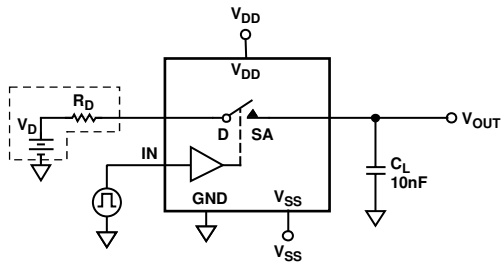

Figure 17. Charge Injection

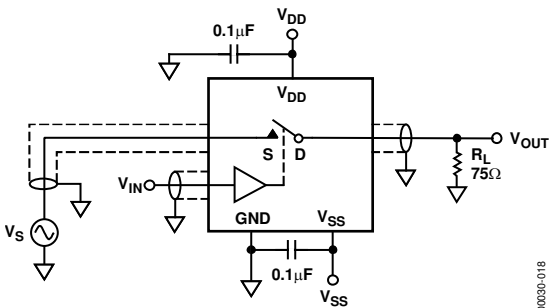

Figure 18. Off Isolation

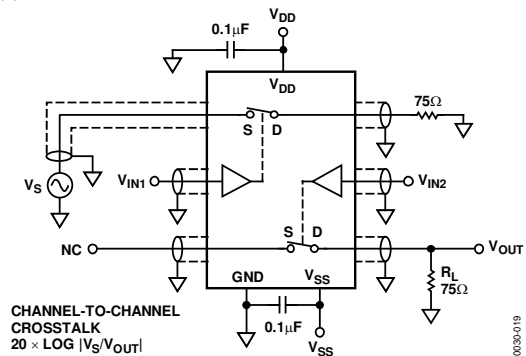

Figure 19. Channel-to Channel Crosstalk

APPLICATIONS INFORMATION

ADG436 SUPPLY VOLTAGES

The ADG436 can operate from a dual or single supply. V_{SS} should be connected to GND when operating with a single supply. When using a dual supply, the ADG436 can also operate with unbalanced supplies, for example $V_{DD} = 20\text{ V}$ and $V_{SS} = -5\text{ V}$. The only restrictions are that V_{DD} to GND must not exceed 30 V, V_{SS} to GND must not drop below -30 V , and V_{DD} to V_{SS} must not exceed +44 V. It is important to remember that the ADG436 supply voltage directly affects the input signal range, the switch on resistance and the switching times of the part. The effects of the power supplies on these characteristics can be clearly seen from the Typical Performance Characteristics curves.

POWER-SUPPLY SEQUENCING

When using CMOS devices, care must be taken to ensure correct power-supply sequencing. Incorrect power-supply sequencing can result in the device being subjected to stresses beyond those listed in the Absolute Maximum Ratings. Always sequence V_{DD} on first followed by V_{SS} and the logic signals. An external signal can then be safely presented to the source or drain of the switch.

OUTLINE DIMENSIONS

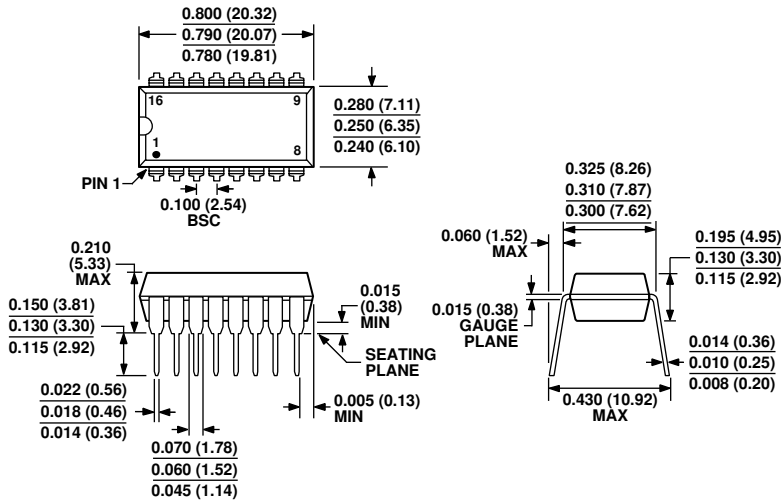

COMPLIANT TO JEDEC STANDARDS MS-001-AB
CONTROLLING DIMENSIONS ARE IN INCHES; MILLIMETER DIMENSIONS (IN PARENTHESES) ARE ROUNDED-OFF INCH EQUIVALENTS FOR REFERENCE ONLY AND ARE NOT APPROPRIATE FOR USE IN DESIGN. CORNER LEADS MAY BE CONFIGURED AS WHOLE OR HALF LEADS.

Figure 20. 16-Lead Plastic Dual In-Line Package [PDIP] (N-16)
Dimensions are shown in inches and (millimeters)

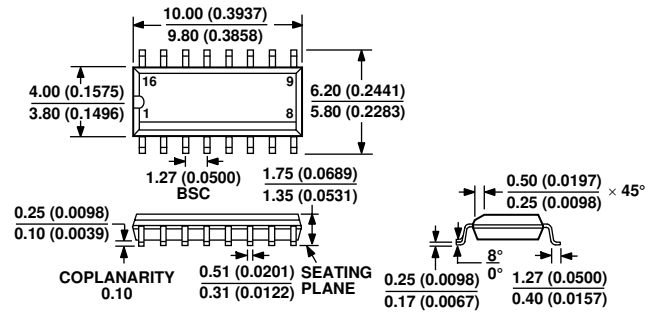

COMPLIANT TO JEDEC STANDARDS MS-012-AC
CONTROLLING DIMENSIONS ARE IN MILLIMETERS; INCH DIMENSIONS (IN PARENTHESES) ARE ROUNDED-OFF MILLIMETER EQUIVALENTS FOR REFERENCE ONLY AND ARE NOT APPROPRIATE FOR USE IN DESIGN

Figure 21. 16-Lead Narrow Body Standard Small Outline Package [SOIC] (R-16)
Dimensions are shown in millimeters and (inches)

ORDERING GUIDE

Model	Temperature Range	Package Description	Package Option
ADG436BN	-40°C to +85°C	16-Lead PDIP	N-16
ADG436BNZ ¹	-40°C to +85°C	16-Lead PDIP	N-16
ADG436BR	-40°C to +85°C	16-Lead 0.15" Narrow Body SOIC	R-16
ADG436BR-REEL	-40°C to +85°C	16-Lead 0.15" Narrow Body SOIC	R-16
ADG436BRZ	-40°C to +85°C	16-Lead 0.15" Narrow Body SOIC	R-16
ADG436BRZ-REEL	-40°C to +85°C	16-Lead 0.15" Narrow Body SOIC	R-16

¹ Z = Pb-free part.