

1.2A, 24V, 700kHz Step-Down Converter

General Description

The RT8258 is a high voltage buck converter that can support the input voltage range from 4.5V to 24V and the output current can be up to 1.2A. Current Mode operation provides fast transient response and eases loop stabilization.

The chip also provides protection functions such as cycle-by-cycle current limiting and thermal shutdown protection. The RT8258 is available in a SOT-23-6 and TSOT-23-6 packages.

Ordering Information

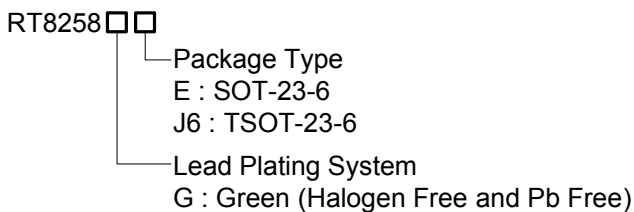

Note :

Richtek products are :

- ▶ RoHS compliant and compatible with the current requirements of IPC/JEDEC J-STD-020.
- ▶ Suitable for use in SnPb or Pb-free soldering processes.

Marking Information

For marking information, contact our sales representative directly or through a Richtek distributor located in your area.

Features

- Wide Operating Input Voltage Range : 4.5V to 24V
- Adjustable Output Voltage Range : 0.8V to 15V
- 1.2A Output Current
- 0.3Ω Internal Power MOSFET Switch
- High Efficiency up to 92%
- 700kHz Fixed Switching Frequency
- Stable with Low ESR Output Ceramic Capacitors
- Thermal Shutdown
- Cycle-By-Cycle Over Current Protection
- RoHS Compliant and Halogen Free

Applications

- Distributed Power Systems
- Battery Charger
- Pre-Regulator for Linear Regulators
- WLED Drivers

Pin Configurations

(TOP VIEW)

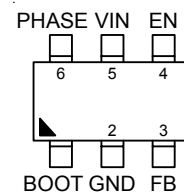

SOT-23-6/TSOT-23-6

Typical Application Circuit

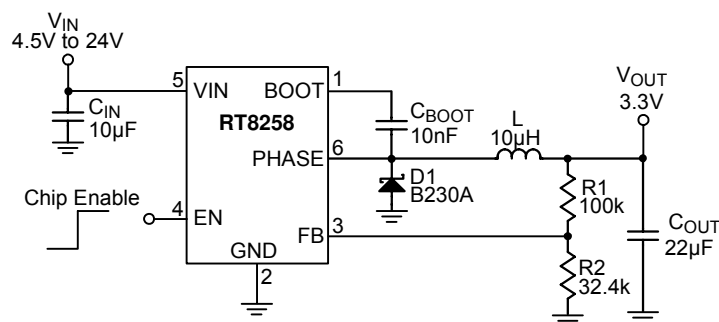
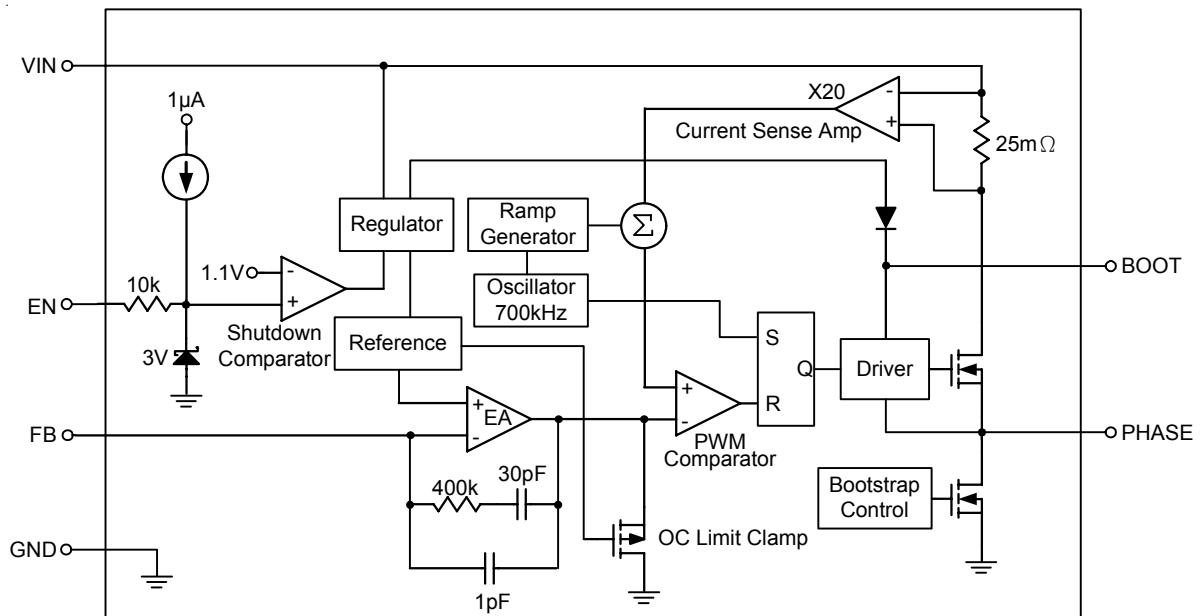

Table 1. Recommended Component Selection

V _{OUT}	1.2V	1.5V	1.8V	2.5V	3.3V	5V	8V	10V	15V
R1 (kΩ)	100	91	91	100	100	91	91	91	120
R2 (kΩ)	200	100	75	47	32.4	17.4	10	7.87	6.8
L (μH)	3.6	3.6	4.7	6.8	10	15	22	22	33
C _{OUT} (μF)	22	22	22	22	22	22	22	22	22

Note : The value of R1 is related to the loop bandwidth of the RT8258. It is strongly recommended to follow the parameters in above table for the specific output voltage.

Function Block Diagram



Functional Pin Description

Pin No.	Pin Name	Pin Function
1	BOOT	Gate Driver Bootstrap Input Pin. Connect a 10nF or greater capacitor between PHASE and BOOT pins to supply the MOSFET driver.
2	GND	Ground Pin. This pin should be connected to the (-) terminal of the output capacitor and it should be kept away from the D1 and input capacitor for noise prevention.
3	FB	Output Voltage Feedback Input Pin. An external resistor divider from the output to GND tapped to the FB pin sets the output voltage. The value of the divider resistors also set loop bandwidth.
4	EN	Chip Enable (Active High). If the EN pin is open, it will be pulled to high by internal circuit.
5	VIN	Power Supply Input Pin. Bypass VIN to GND with a suitable large capacitor to prevent large voltage spikes from appearing at the input.
6	PHASE	Power Switching Output Pin. Connect this pin to the output inductor.

Absolute Maximum Ratings (Note 1)

- Supply Voltage, V_{IN} ----- 26V
- PHASE Voltage ----- $-0.3V$ to $(V_{IN} + 0.3V)$
- BOOT Voltage ----- $V_{PHASE} + 6V$
- All Other Pins ----- 0.3V to 6V
- Power Dissipation, P_D @ $T_A = 25^\circ C$
 T/SOT-23-6 ----- 0.4W
- Package Thermal Resistance (Note 2)
 T/SOT-23-6, θ_{JA} ----- $250^\circ C/W$
- Junction Temperature ----- $150^\circ C$
- Lead Temperature (Soldering, 10 sec.) ----- $260^\circ C$
- Storage Temperature Range ----- $-65^\circ C$ to $150^\circ C$
- ESD Susceptibility (Note 3)
 HBM (Human Body Mode) ----- 2kV
 MM (Machine Mode) ----- 200V

Recommended Operating Conditions (Note 4)

- Supply Voltage, V_{IN} ----- 4.5V to 24V
- Output Voltage, V_{OUT} ----- 0.8V to 15V
- EN Voltage, V_{EN} ----- 0V to 5.5V
- Junction Temperature Range ----- $-40^\circ C$ to $125^\circ C$
- Ambient Temperature Range ----- $-40^\circ C$ to $85^\circ C$

Electrical Characteristics

($V_{IN} = 12V$, $T_A = 25^\circ C$ unless otherwise specified)

Parameter	Symbol	Test Conditions	Min	Typ	Max	Unit
Feedback Reference Voltage	V_{FB}	$4.5V \leq V_{IN} \leq 24V$	0.784	0.8	0.816	V
Feedback Current	I_{FB}	$V_{FB} = 0.8V$	--	0.1	0.3	μA
Switch On Resistance	$R_{DS(ON)}$		--	0.3	--	Ω
Switch Leakage		$V_{EN} = 0V$, $V_{PHASE} = 0V$	--	--	10	μA
Current Limit	I_{LIM}	$V_{BOOT} - V_{PHASE} = 4.8V$	1.6	2.1	--	A
Oscillator Frequency	f_{SW}		600	700	800	kHz
Maximum Duty Cycle			--	90	--	%
Minimum On-Time	t_{ON}		--	100	--	ns
Under Voltage Lockout Threshold Voltage		Rising	3.9	4.2	4.5	V
Under Voltage Lockout Threshold Hysteresis			--	270	--	mV
EN Input Voltage	Logic High		1.4	--	--	V
	Logic Low		--	--	0.4	
EN Pull Up Current		$V_{EN} = 0V$	--	1	--	μA
Shutdown Current	I_{SHDN}	$V_{EN} = 0V$	--	25	--	μA
Quiescent Current	I_Q	$V_{EN} = 2V$, $V_{FB} = 1V$ (No Switching)	--	0.55	1	mA
Thermal Shutdown	T_{SD}		--	150	--	$^\circ C$

Note 1. Stresses listed as the above "Absolute Maximum Ratings" may cause permanent damage to the device. These are for stress ratings. Functional operation of the device at these or any other conditions beyond those indicated in the operational sections of the specifications is not implied. Exposure to absolute maximum rating conditions for extended periods may remain possibility to affect device reliability.

Note 2. θ_{JA} is measured in the natural convection at $T_A = 25^\circ\text{C}$ on a low effective single layer thermal conductivity test board of JEDEC 51-3 thermal measurement standard.

Note 3. Devices are ESD sensitive. Handling precaution is recommended.

Note 4. The device is not guaranteed to function outside its operating conditions.

Typical Operating Characteristics

Efficiency vs. Output Current

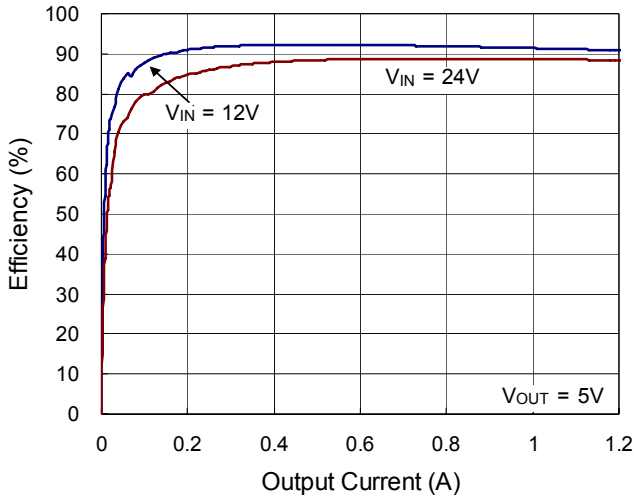

Efficiency vs. Output Current

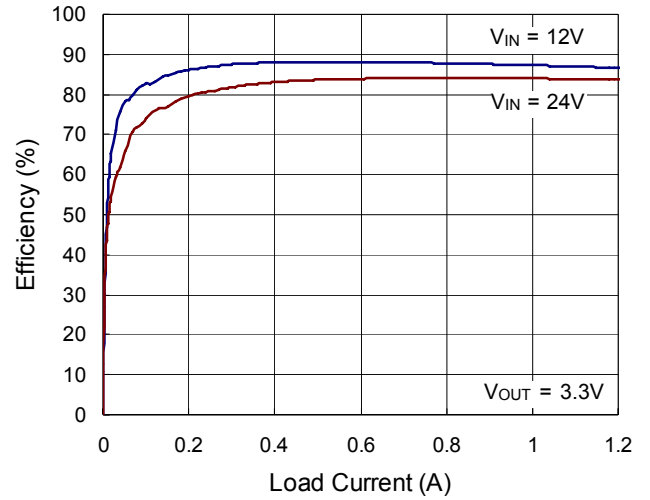

Output Voltage vs. Output Current

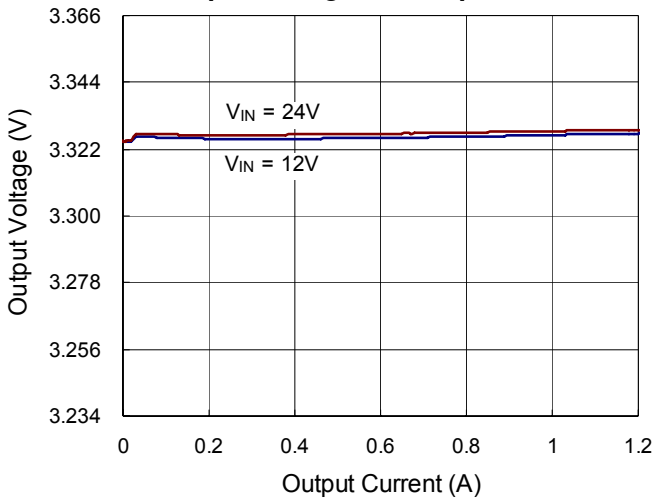

Output Voltage vs. Temperature

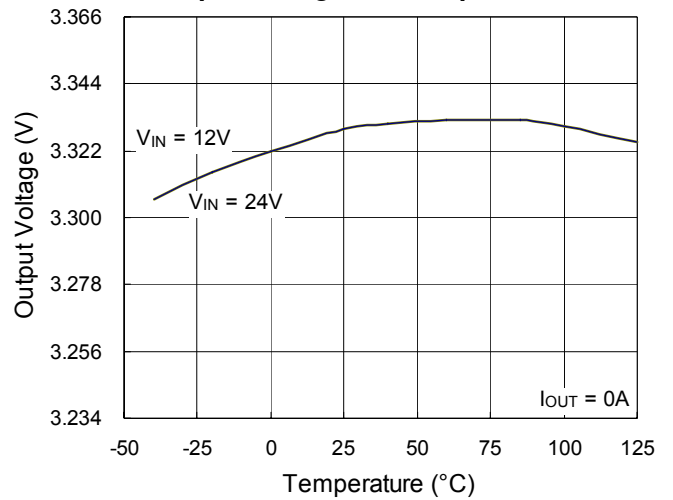

Frequency vs. Temperature

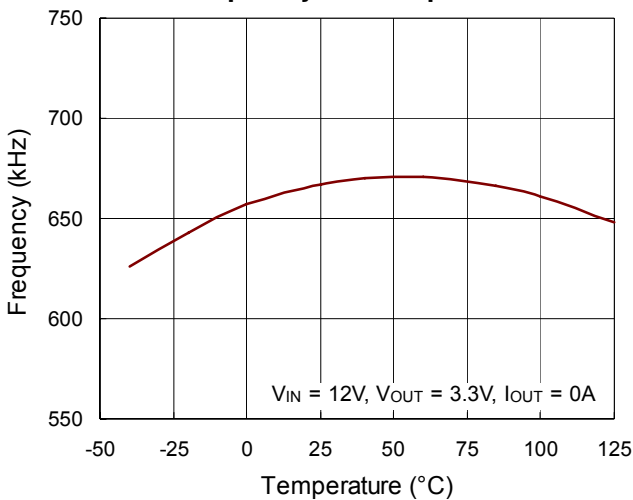

Quiescent Current vs. Temperature

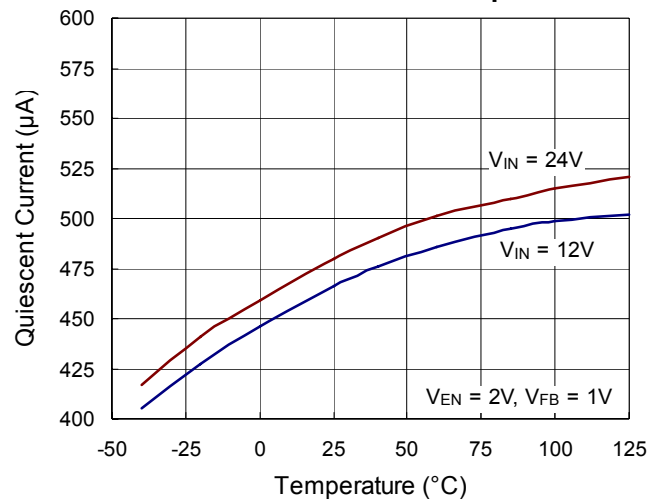

Power On from EN

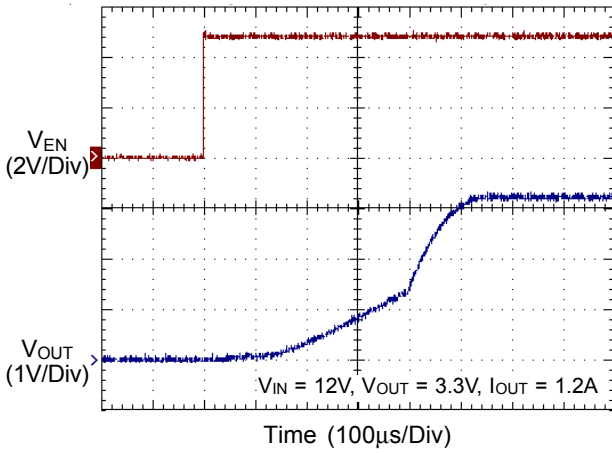

Power Off from EN

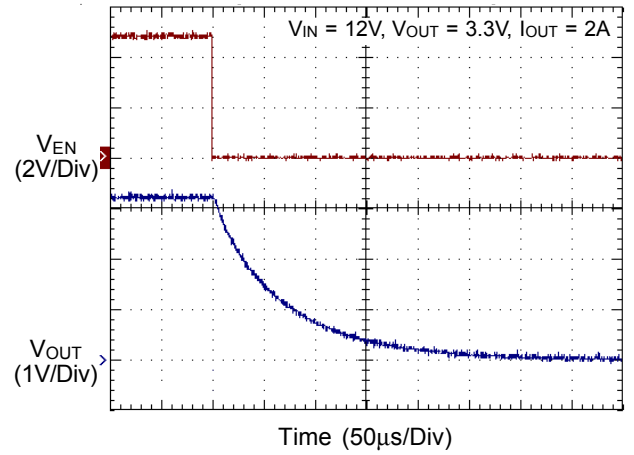

Output Ripple Voltage

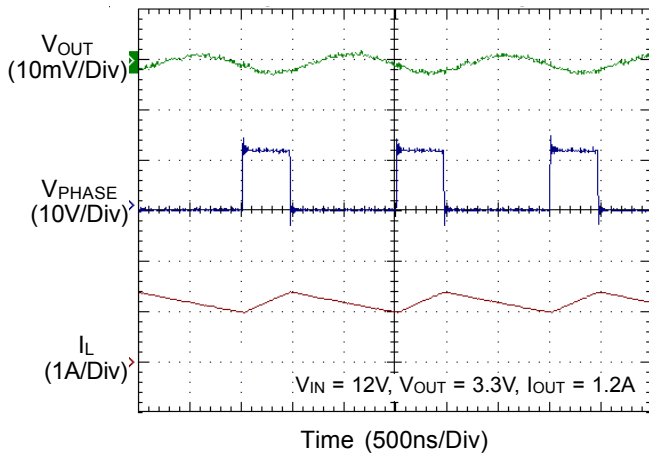

Output Ripple Voltage

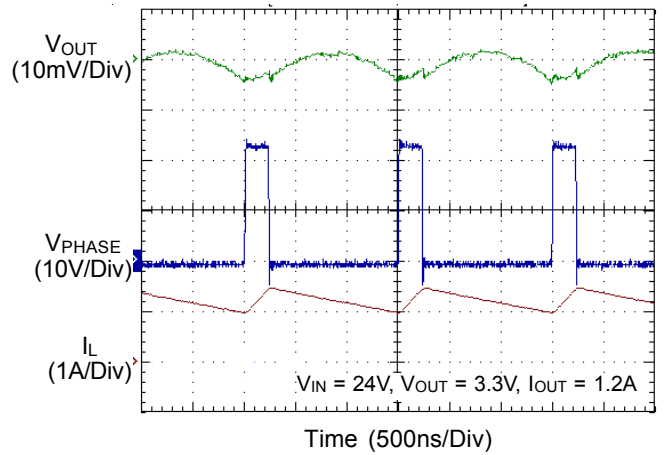

Load Transient Response

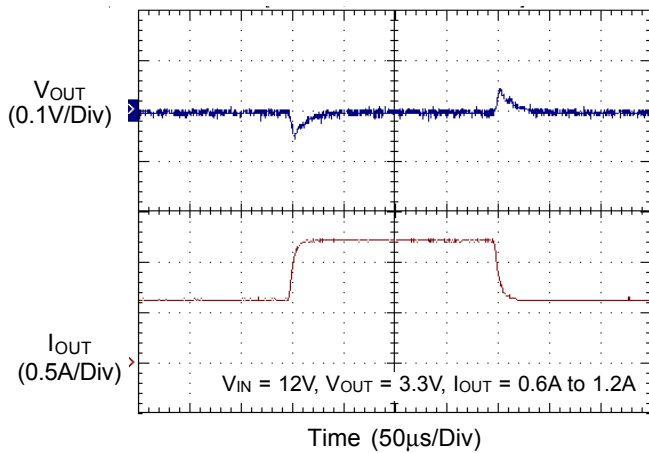

Load Transient Response

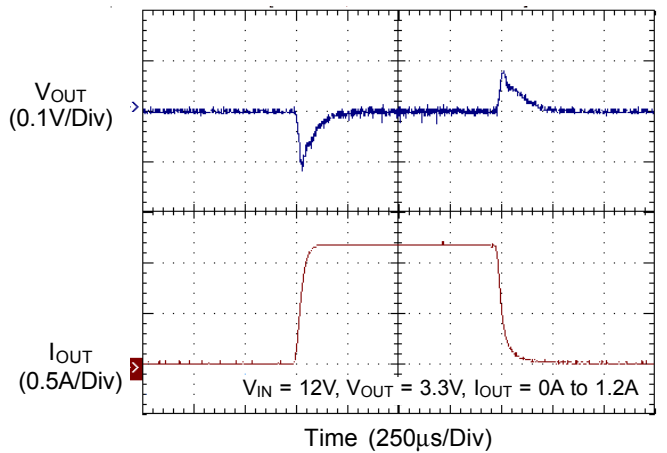

Application Information

The RT8258 is an asynchronous high voltage buck converter that can support the input voltage range from 4.5V to 24V and the output current can be up to 1.2A.

Output Voltage Setting

The resistive voltage divider allows the FB pin to sense a fraction of the output voltage as shown in Figure 1.

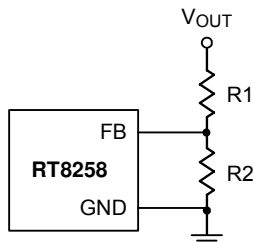

Figure 1. Output Voltage Setting

For adjustable voltage mode, the output voltage is set by an external resistive voltage divider according to the following equation :

$$V_{OUT} = V_{FB} \left(1 + \frac{R1}{R2} \right)$$

Where V_{FB} is the feedback reference voltage (0.8V typ.).

External Bootstrap Diode

Connect a 10nF low ESR ceramic capacitor between the BOOT pin and PHASE pin. This capacitor provides the gate driver voltage for the high side MOSFET.

It is recommended to add an external bootstrap diode between an external 5V and the BOOT pin for efficiency improvement when input voltage is lower than 5.5V or duty ratio is higher than 65%. The bootstrap diode can be a low cost one such as 1N4148 or BAT54.

The external 5V can be a 5V fixed input from system or a 5V output of the RT8268.

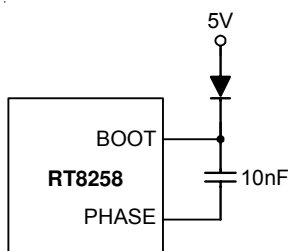

Figure 2. External Bootstrap Diode

Inductor Selection

The inductor value and operating frequency determine the ripple current according to a specific input and output voltage. The ripple current ΔI_L increases with higher V_{IN} and decreases with higher inductance.

$$\Delta I_L = \left[\frac{V_{OUT}}{f \times L} \right] \times \left[1 - \frac{V_{OUT}}{V_{IN}} \right]$$

Having a lower ripple current reduces not only the ESR losses in the output capacitors but also the output voltage ripple. High frequency with small ripple current can achieve highest efficiency operation. However, it requires a large inductor to achieve this goal.

For the ripple current selection, the value of $\Delta I_L = 0.34(I_{MAX})$ will be a reasonable starting point. The largest ripple current occurs at the highest V_{IN} . To guarantee that the ripple current stays below the specified maximum, the inductor value should be chosen according to the following equation :

$$L = \left[\frac{V_{OUT}}{f \times \Delta I_L(MAX)} \right] \times \left[1 - \frac{V_{OUT}}{V_{IN(MAX)}} \right]$$

Inductor Core Selection

The inductor type must be selected once the value for L is known. Generally speaking, high efficiency converters can not afford the core loss found in low cost powdered iron cores. So, the more expensive ferrite or mollypermalloy cores will be a better choice.

The selected inductance rather than the core size for a fixed inductor value is the key for actual core loss. As the inductance increases, core losses decrease. Unfortunately, increase of the inductance requires more turns of wire and therefore the copper losses will increase.

Ferrite designs are preferred at high switching frequency due to the characteristics of very low core losses. So, design goals can focus on the reduction of copper loss and the saturation prevention.

Ferrite core material saturates “hard”, which means that inductance collapses abruptly when the peak design current is exceeded. The previous situation results in an abrupt increase in inductor ripple current and consequent output voltage ripple.

Do not allow the core to saturate!

Different core materials and shapes will change the size/current and price/current relationship of an inductor.

Toroid or shielded pot cores in ferrite or permalloy materials are small and do not radiate energy. However, they are usually more expensive than the similar powdered iron inductors. The rule for inductor choice mainly depends on the price vs. size requirement and any radiated field/EMI requirements.

Diode Selection

When the power switch turns off, the path for the current is through the diode connected between the switch output and ground. This forward biased diode must have a minimum voltage drop and recovery times. Schottky diode is recommended and it should be able to handle those current. The reverse voltage rating of the diode should be greater than the maximum input voltage, and current rating should be greater than the maximum load current. For more detail, please refer to Table 3.

C_{IN} and C_{OUT} Selection

The input capacitance, C_{IN}, is needed to filter the trapezoidal current at the source of the top MOSFET. To prevent large ripple current, a low ESR input capacitor sized for the maximum RMS current should be used. The RMS current is given by :

$$I_{RMS} = I_{OUT(MAX)} \frac{V_{OUT}}{V_{IN}} \sqrt{\frac{V_{IN}}{V_{OUT}} - 1}$$

This formula has a maximum at V_{IN} = 2V_{OUT}, where I_{RMS} = I_{OUT}/2. This simple worst-case condition is commonly used for design because even significant deviations do not offer much relief.

Choose a capacitor rated at a higher temperature than required. Several capacitors may also be paralleled to meet size or height requirements in the design.

The selection of C_{OUT} is determined by the required Effective Series Resistance (ESR) to minimize voltage ripple.

Moreover, the amount of bulk capacitance is also a key for C_{OUT} selection to ensure that the control loop is stable. Loop stability can be checked by viewing the load transient response as described in a later section.

The output ripple, ΔV_{OUT}, is determined by :

$$\Delta V_{OUT} \leq \Delta I_L \left[ESR + \frac{1}{8fC_{OUT}} \right]$$

The output ripple will be highest at the maximum input voltage since ΔI_L increases with input voltage. Multiple capacitors placed in parallel may be needed to meet the ESR and RMS current handling requirement. Dry tantalum, special polymer, aluminum electrolytic and ceramic capacitors are all available in surface mount packages. Special polymer capacitors offer very low ESR value. However, it provides lower capacitance density than other types. Although Tantalum capacitors have the highest capacitance density, it is important to only use types that pass the surge test for use in switching power supplies. Aluminum electrolytic capacitors have significantly higher ESR. However, it can be used in cost-sensitive applications for ripple current rating and long term reliability considerations. Ceramic capacitors have excellent low ESR characteristics but can have a high voltage coefficient and audible piezoelectric effects. The high Q of ceramic capacitors with trace inductance can also lead to significant ringing.

Higher values, lower cost ceramic capacitors are now becoming available in smaller case sizes. Their high ripple current, high voltage rating and low ESR make them ideal for switching regulator applications. However, care must be taken when these capacitors are used at input and output. When a ceramic capacitor is used at the input and the power is supplied by a wall adapter through long wires, a load step at the output can induce ringing at the input, V_{IN}. At best, this ringing can couple to the output and be mistaken as loop instability. At worst, a sudden inrush of current through the long wires can potentially cause a voltage spike at V_{IN} large enough to damage the part.

Checking Transient Response

The regulator loop response can be checked by looking at the load transient response. Switching regulators take several cycles to respond to a step in load current. When a load step occurs, V_{OUT} immediately shifts by an amount equal to ΔI_{LOAD} (ESR) and also begins to charge or discharge C_{OUT} generating a feedback error signal for the regulator to return V_{OUT} to its steady-state value. During this recovery time, V_{OUT} can be monitored for overshoot or ringing that would indicate a stability problem.

Thermal Considerations

For continuous operation, do not exceed the maximum operation junction temperature 125°C. The maximum power dissipation depends on the thermal resistance of IC package, PCB layout, the rate of surroundings airflow and temperature difference between junction to ambient. The maximum power dissipation can be calculated by following formula :

$$P_{D(MAX)} = (T_{J(MAX)} - T_A) / \theta_{JA}$$

where $T_{J(MAX)}$ is the maximum operation junction temperature, T_A is the ambient temperature and the θ_{JA} is the junction to ambient thermal resistance.

For recommended operating conditions specification of the RT8258, the maximum junction temperature of the die is 125°C. The junction to ambient thermal resistance θ_{JA} is layout dependent. For T/SOT-23-6 package, the thermal resistance θ_{JA} is 250°C/W on standard JEDEC 51-3 single layer thermal test board. The maximum power dissipation at $T_A = 25^\circ\text{C}$ can be calculated by following formula :

$$P_{D(MAX)} = (125^\circ\text{C} - 25^\circ\text{C}) / (250^\circ\text{C/W}) = 0.4\text{W for T/SOT-23-6 package}$$

The maximum power dissipation depends on operating ambient temperature for fixed $T_{J(MAX)}$ and thermal resistance θ_{JA} . For RT8258 package, the Figure 3 of derating curve allows the designer to see the effect of rising ambient temperature on the maximum power dissipation allowed.

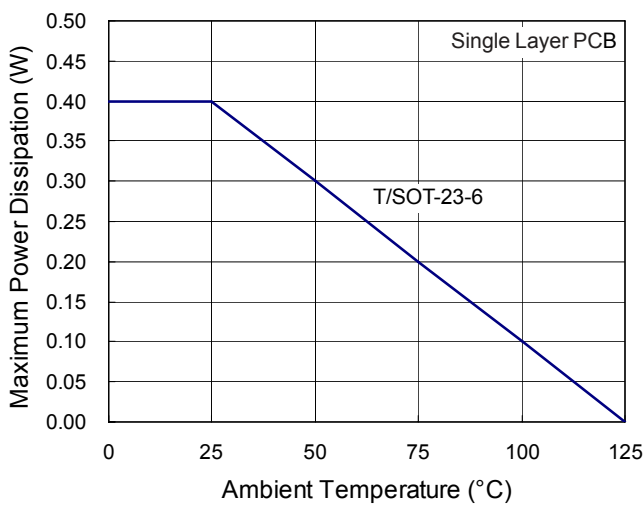

Figure 3. Derating Curve for RT8258 Package

Layout Consideration

Follow the PCB layout guidelines for optimal performance of RT8258.

- ▶ Keep the traces of the main current paths as short and wide as possible.
- ▶ Put the input capacitor as close as possible to the device pins (VIN and GND).
- ▶ PHASE node is with high frequency voltage swing and should be kept at small area. Keep sensitive components away from the PHASE node to prevent stray capacitive noise pick-up.
- ▶ Place the feedback components to the FB pin as close as possible.
- ▶ Connect the GND to a ground plane for noise reduction and thermal dissipation.

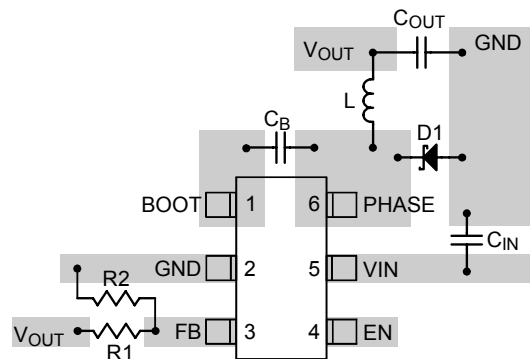

Figure 4. PCB Layout Guide

Table 2. Suggested Inductors for L

Component Supplier	Series	Dimensions (mm)
TDK	SLF12555T	12.5x12.5x5.5
TAIYO YUDEN	NR8040	8x8x4
TDK	SLF12565T	12.5x12.5x6.5

Table 3. Suggested Capacitors for C_{IN} and C_{OUT}

Location	Component Supplier	Part No.	Capacitance (μF)	Case Size
C _{IN}	MURATA	GRM31CR61E106K	10	1206
C _{IN}	TDK	C3225X5R1E106K	10	1206
C _{IN}	TAIYO YUDEN	TMK316BJ106ML	10	1206
C _{OUT}	MURATA	GRM31CR61C226M	22	1206
C _{OUT}	TDK	C3225X5R1C226M	22	1206
C _{OUT}	TAIYO YUDEN	EMK316BJ226ML	22	1206

Table 4. Suggested Diode for D1

Component Supplier	Series	V _{RRM} (V)	I _{OUT} (A)	Package
DIODES	B230A	30	2	DO-214AC
DIODES	B330A	30	3	DO-214AC
PANJIT	SK23	30	2	DO-214AC
PANJIT	SK33	30	3	DO-214AB

Outline Dimension

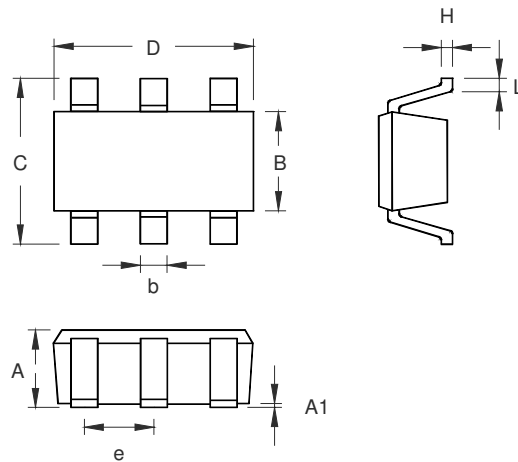

Symbol	Dimensions In Millimeters		Dimensions In Inches	
	Min	Max	Min	Max
A	0.889	1.295	0.031	0.051
A1	0.000	0.152	0.000	0.006
B	1.397	1.803	0.055	0.071
b	0.250	0.560	0.010	0.022
C	2.591	2.997	0.102	0.118
D	2.692	3.099	0.106	0.122
e	0.838	1.041	0.033	0.041
H	0.080	0.254	0.003	0.010
L	0.300	0.610	0.012	0.024

SOT-23-6 Surface Mount Package

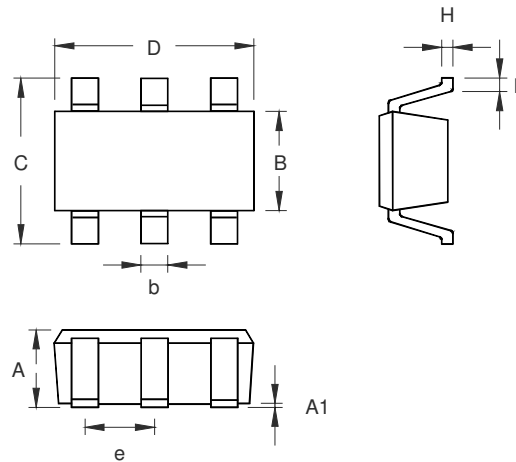

Symbol	Dimensions In Millimeters		Dimensions In Inches	
	Min	Max	Min	Max
A	0.700	1.000	0.028	0.039
A1	0.000	0.100	0.000	0.004
B	1.397	1.803	0.055	0.071
b	0.300	0.559	0.012	0.022
C	2.591	3.000	0.102	0.118
D	2.692	3.099	0.106	0.122
e	0.838	1.041	0.033	0.041
H	0.080	0.254	0.003	0.010
L	0.300	0.610	0.012	0.024

TSOT-23-6 Surface Mount Package

Richtek Technology Corporation

Headquarter
 5F, No. 20, Taiyuen Street, Chupei City
 Hsinchu, Taiwan, R.O.C.
 Tel: (8863)5526789 Fax: (8863)5526611

Richtek Technology Corporation

Taipei Office (Marketing)
 5F, No. 95, Minchiuan Road, Hsintien City
 Taipei County, Taiwan, R.O.C.
 Tel: (8862)86672399 Fax: (8862)86672377
 Email: marketing@richtek.com

Information that is provided by Richtek Technology Corporation is believed to be accurate and reliable. Richtek reserves the right to make any change in circuit design, specification or other related things if necessary without notice at any time. No third party intellectual property infringement of the applications should be guaranteed by users when integrating Richtek products into any application. No legal responsibility for any said applications is assumed by Richtek.