

NPN Silicon Phototransistor

OP600 Series



Features:

- Narrow receiving angle
- Variety of sensitivity ranges
- Enhanced temperature range
- PC Board Mounting
- Mechanically and spectrally matched to OP123 and OP223 LEDs
- TXV and S processing available (see Hi-Rel section)



Description:

Each device in this series is a NPN silicon phototransistor in a hermetically sealed pill package. The narrow receiving angle provides excellent on-axis coupling.

The **OP600** series devices are 100% production tested using infrared light for close correlation with OPTEK GaAs and GaAlAs emitters. Components in the OP600 series are mechanically and spectrally matched to the OP123 and OP233 series.

TXV and S components are available. For more information, please contact your local representative or OPTEK.

Please refer to Application Bulletins 208 and 210 for additional information and reliability (degradation) data, and to Application Bulletin 202 for pill-type soldering to PC Board.

Applications:

- Non-contact reflective object sensor
- Machine safety
- Assembly line automation
- End of travel sensor
- Machine automation
- Door sensor

Ordering Information				
Part Number	Sensor	Light Current $I_{C(ON)}$ (mA) Min / Max	Input Power E_E (mW/cm ²)	Viewing Angle
OP600A	Transistor	1.20 / NA	2.5	35°
OP600B		0.60 / 1.80		
OP600C		0.30 / NA		
OP643SL		4.00 / 8.00	20.0	
OP644SL		7.00 / 22.00		

Pin #	Sensor
1	Collector/Cathode
2	Emitter/Anode

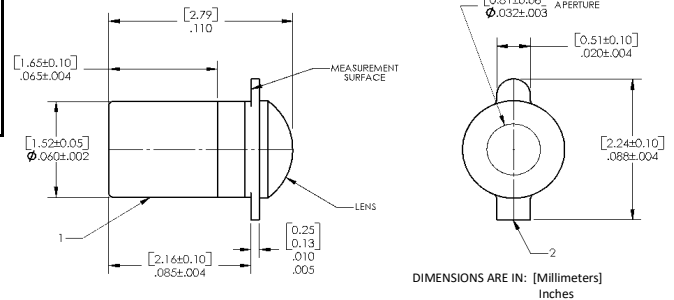
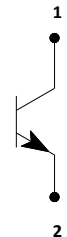

DO NOT LOOK DIRECTLY AT LED WITH UNSHIELDED EYES OR DAMAGE TO RETINA MAY OCCUR.

General Note

TT Electronics reserves the right to make changes in product specification without notice or liability. All information is subject to TT Electronics' own data and is considered accurate at time of going to print.

TT Electronics | OPTEK Technology
2900 E. Plano Pkwy, Plano, TX 75074 | Ph: +1 972 323 2200
www.ttelectronics.com | sensors@ttelectronics.com

Electrical Specifications

Absolute Maximum Ratings ($T_A = 25^\circ\text{C}$ unless otherwise noted)

Collector-Emitter Voltage	25 V
Emitter-Collector Voltage	5 V
Storage Temperature Range	-65° C to +150° C
Operating Temperature Range	-65° C to +125° C
Soldering Temperature (5 seconds with soldering iron)	260° C ⁽¹⁾⁽²⁾
Power Dissipation	50 mW ⁽³⁾
Continuous Collector Current	50 mA

Electrical Characteristics ($T_A = 25^\circ\text{C}$ unless otherwise noted)

SYMBOL	PARAMETER	MIN	TYP	MAX	UNITS	TEST CONDITIONS
$I_{C(ON)}$ ⁽⁴⁾	On-State Collector Current					
	OP600A	1.2	-	1.8	mA	$V_{CE} = 5\text{ V}, E_E = 2.5\text{ mW/cm}^{2(5)}$
	OP600B	0.6	-	1.8		
	OP600C	0.3	-	1.8		
OP643SL	4.0	-	8.0	$V_{CE} = 5\text{ V}, E_E = 20\text{ mW/cm}^{2(5)}$		
OP644SL	7.0	-	22.0			
I_{CEO}	Collector-Dark Current	-	-	100	nA	$V_{CE} = 10\text{ V}, E_E = 0$
$V_{(BR)CEO}$	Collector-Emitter Breakdown Voltage	25	-	-	V	$I_C = 100\ \mu\text{A}$
$V_{(BR)ECO}$	Emitter-Collector Breakdown Voltage	5	-	-	V	$I_E = 100\ \mu\text{A}$
$V_{CE(SAT)}$ ⁽⁴⁾	Collector-Emitter					
	OP600 (A, B, C) ⁽²⁾⁽⁷⁾ OP643-644 (SL) ⁽²⁾⁽⁷⁾	-	-	0.4	V	$I_C = 0.15\text{ mA}, E_E = 2.5\text{ mW/cm}^{2(5)}$ $I_C = 0.4\text{ mA}, E_E = 20\text{ mW/cm}^{2(5)}$
t_r	Rise Time	-	15	-	μs	$V_{CC} = 5\text{ V}, I_C = 0.80\text{ mA}, R_L = 1\text{ k}\Omega$, See Test Circuit
t_f	Fall Time	-	15	-	μs	$V_{CC} = 5\text{ V}, I_C = 0.80\text{ mA}, R_L = 1\text{ k}\Omega$, See Test Circuit

Notes:

- Refer to Application Bulletin 202, which discusses proper techniques for soldering pill-type devices to PCBoards.
- No clean or low solids. RMA flux is recommended. Duration can be extended to 10 seconds maximum when flow soldering.
- Derate linearly 0.5 mW/° C above 25° C.
- Junction temperature maintained at 25° C.
- For OP600A, OP600B and OP600C, light source is a GaAlAs LED, peak wavelength = 890 nm, that provides irradiance of 2.5 mW/cm². The source irradiance is not necessarily uniform over the entire lens area of the unit being tested.
- For OP643SL and OP644SL, light source is an unfiltered tungsten bulb operating at CT = 2870 K or equivalent infrared source.

General Note

TT Electronics reserves the right to make changes in product specification without notice or liability. All information is subject to TT Electronics' own data and is considered accurate at time of going to print.