

LEAD FINISH (SnPb) ARE IN EOL PROCESS - LAST TIME BUY EXPIRES JUNE 15, 2018

FEATURES:

- The IDT72801 is equivalent to two IDT72201 256 x 9 FIFOs
- The IDT72811 is equivalent to two IDT72211 512 x 9 FIFOs
- The IDT72821 is equivalent to two IDT72221 1,024 x 9 FIFOs
- The IDT72831 is equivalent to two IDT72231 2,048 x 9 FIFOs
- The IDT72841 is equivalent to two IDT72241 4,096 x 9 FIFOs
- The IDT72851 is equivalent to two IDT72251 8,192 x 9 FIFOs
- Offers optimal combination of large capacity, high speed, design flexibility and small footprint
- Ideal for prioritization, bidirectional, and width expansion applications
- 10 ns read/write cycle time for the IDT72801/72811/72821/72831/72841/72851
- Separate control lines and data lines for each FIFO
- Separate Empty, Full, Programmable Almost-Empty and Almost-Full flags for each FIFO
- Enable puts output data lines in high-impedance state
- Space-saving 64-pin Thin Quad Flat Pack (TQFP) and Slim Thin Quad Flatpack (STQFP)
- Industrial temperature range (-40°C to +85°C) is available
- Green parts available, see ordering information

DESCRIPTION:

The IDT72801/72811/72821/72831/72841/72851 are dual synchronous (clocked) FIFOs. The device is functionally equivalent to two IDT72201/72211/72221/72231/72241/72251 FIFOs in a single package with all associated control, data, and flag lines assigned to separate pins.

Each of the two FIFOs (designated FIFO A and FIFO B) contained in the IDT72801/72811/72821/72831/72841/72851 has a 9-bit input data port (DA0 - DA8, DB0 - DB8) and a 9-bit output data port (QA0 - QA8, QB0 - QB8). Each input port is controlled by a free-running clock (WCLKA, WCLKB), and two Write Enable pins ($\overline{WENA1}$, $\overline{WENA2}$, $\overline{WENB1}$, $\overline{WENB2}$). Data is written into each of the two arrays on every rising clock edge of the Write Clock (WCLKA, WCLKB) when the appropriate write enable pins are asserted.

The output port of each FIFO bank is controlled by its associated clock pin (RCLKA, RCLKB) and two Read Enable pins ($\overline{RENA1}$, $\overline{RENA2}$, $\overline{RENB1}$, $\overline{RENB2}$). The Read Clock can be tied to the Write Clock for single clock operation or the two clocks can run asynchronous of one another for dual clock operation. An Output Enable pin (\overline{OEA} , \overline{OEB}) is provided on the read port of each FIFO for three-state output control.

Each of the two FIFOs has two fixed flags, Empty (\overline{EFA} , \overline{EFB}) and Full (\overline{FFA} , \overline{FFB}). Two programmable flags, Almost-Empty (\overline{PAEA} , \overline{PAEB}) and Almost-Full (\overline{PAFA} , \overline{PAFB}), are provided for each FIFO bank to improve memory utilization. If not programmed, the programmable flags default to empty+7 for \overline{PAEA} and \overline{PAEB} , and full-7 for \overline{PAFA} and \overline{PAFB} .

The IDT72801/72811/72821/72831/72841/72851 architecture lends itself to many flexible configurations such as:

- 2-level priority data buffering
- Bidirectional operation
- Width expansion
- Depth expansion

These FIFOs are fabricated using high-performance submicron CMOS technology.

FUNCTIONAL BLOCK DIAGRAM

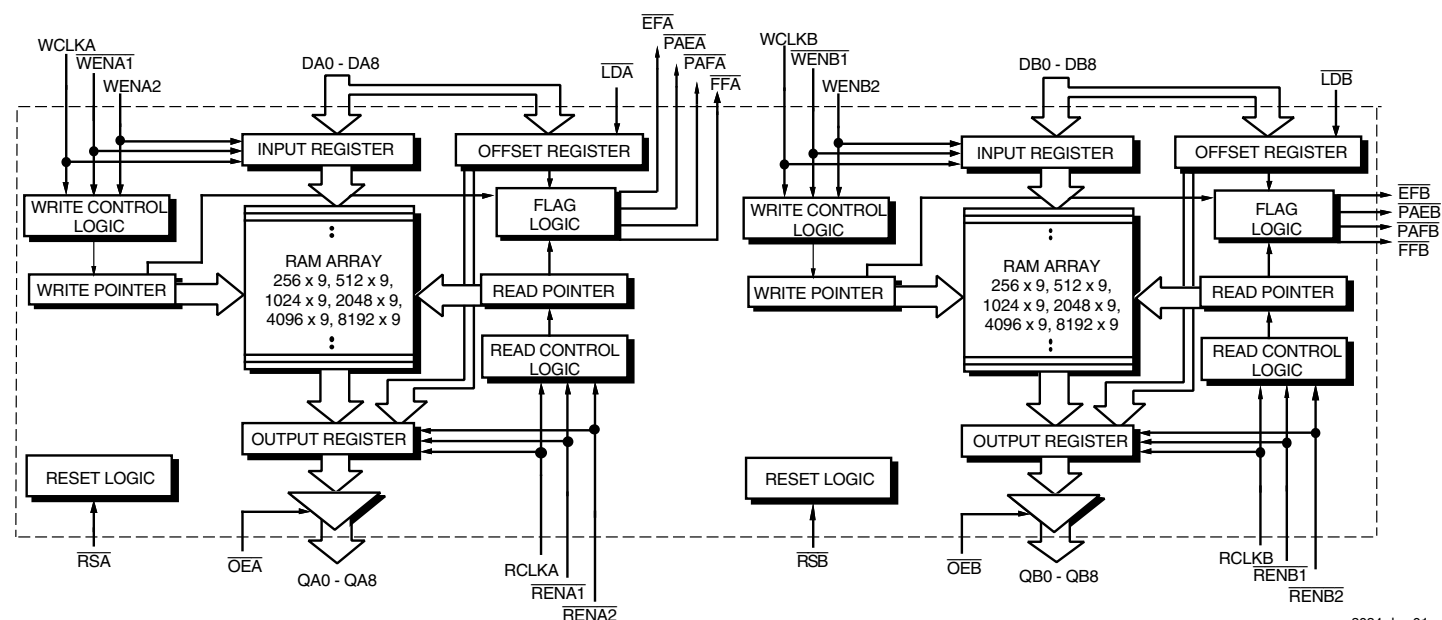

3034 drw 01

IDT, IDT logo and the SyncFIFO logo are registered trademarks of Integrated Device Technology, Inc.

COMMERCIAL AND INDUSTRIAL TEMPERATURE RANGE

FEBRUARY 2018

PIN CONFIGURATION

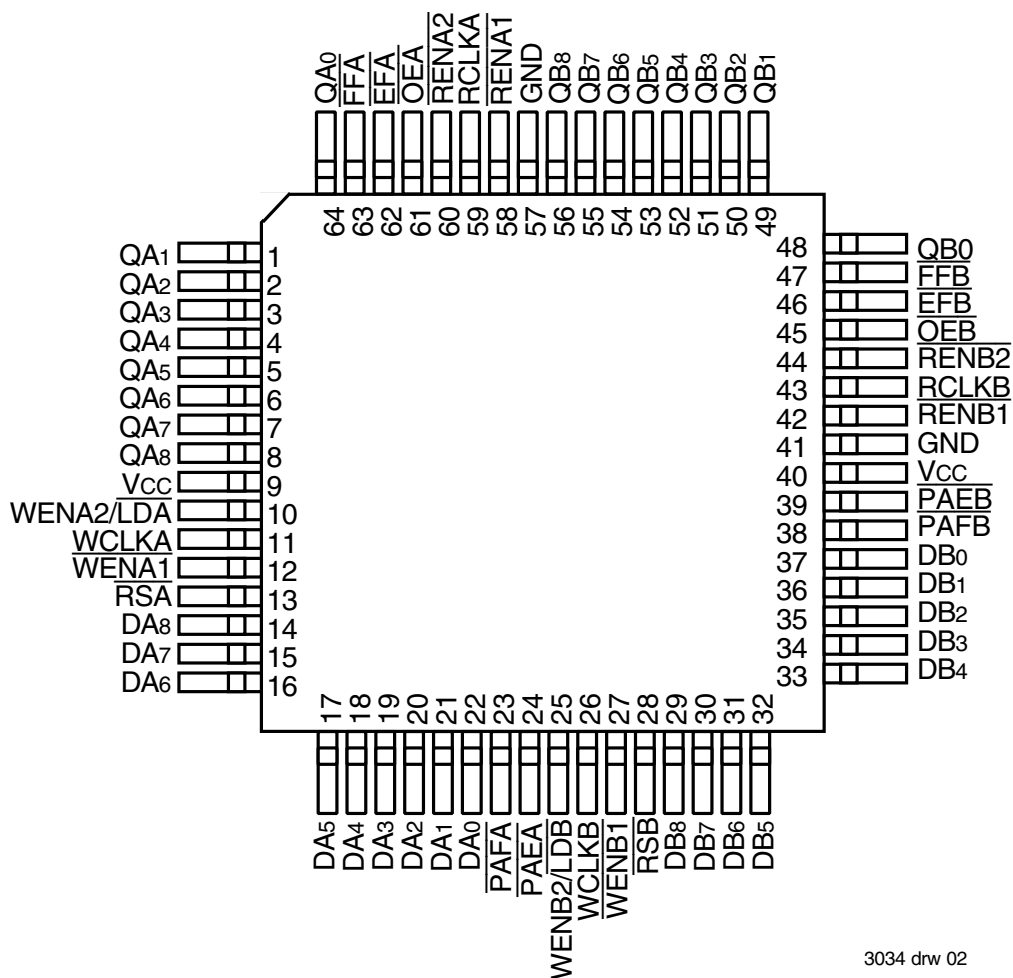

3034 drw 02

TQFP (PN64-1, order code: PF)
 STQFP (PP64-1, order code: TF)
 TOP VIEW

PIN DESCRIPTIONS

The IDT72801/72811/72821/72831/72841/72851s two FIFOs, referred to as FIFO A and FIFO B, are identical in every respect. The following description defines the input and output signals for FIFO A. The corresponding signal names for FIFO B are provided in parentheses.

Symbol	Name	I/O	Description
DA0-DA8	A Data Inputs	I	9-bit data inputs to RAM array A.
DB0-DB8	B Data Inputs	I	9-bit data inputs to RAM array B.
\overline{RSA} , \overline{RSB}	Reset	I	When \overline{RSA} (\overline{RSB}) is set LOW, the associated internal read and write pointers of array A (B) are set to the first location; \overline{FFA} (\overline{FFB}) and \overline{PAFA} (\overline{PAFB}) go HIGH, and \overline{PAEA} (\overline{PAEB}) and \overline{EFA} (\overline{EFB}) go LOW. After power-up, a reset of both FIFOs A and B is required before an initial Write.
WCLKA WCLKB	Write Clock	I	Data is written into the FIFO A (B) on a LOW-to-HIGH transition of WCLKA (WCLKB) when the write enable(s) are asserted.
$\overline{WENA1}$ $\overline{WENB1}$	Write Enable 1	I	If FIFO A (B) is configured to have programmable flags, $\overline{WENA1}$ ($\overline{WENB1}$) is the only Write Enable pin that can be used. When $\overline{WENA1}$ ($\overline{WENB1}$) is LOW, data A (B) is written into the FIFO on every LOW-to-HIGH transition WCLKA (WCLKB). If the FIFO is configured to have two write enables, $\overline{WENA1}$ ($\overline{WENB1}$) must be LOW and WENA2 (WENB2) must be HIGH to write data into the FIFO. Data will not be written into the FIFO if \overline{FFA} (\overline{FFB}) is LOW.
WENA2/ \overline{LDA} WENB2/ \overline{LDB}	Write Enable 2/ Load	I	FIFO A (B) is configured at reset to have either two write enables or programmable flags. If \overline{LDA} (\overline{LDB}) is HIGH at reset, this pin operates as a second write enable. If WENA2/ \overline{LDA} (WENB2/ \overline{LDB}) is LOW at reset this pin operates as a control to load and read the programmable flag offsets for its respective array. If the FIFO is configured to have two write enables, $\overline{WENA1}$ ($\overline{WENB1}$) must be LOW and WENA2 (WENB2) must be HIGH to write data into FIFO A (B). Data will not be written into FIFO A (B) if \overline{FFA} (\overline{FFB}) is LOW. If the FIFO is configured to have programmable flags, \overline{LDA} (\overline{LDB}) is held LOW to write or read the programmable flag offsets.
QA0-QA8	A Data Outputs	O	9-bit data outputs from RAM array A.
QB0-QB8	B Data Outputs	O	9-bit data outputs from RAM array B.
RCLKA RCLKB	Read Clock	I	Data is read from FIFO A (B) on a LOW-to-HIGH transition of RCLKA (RCLKB) when $\overline{RENA1}$ ($\overline{RENB1}$) and $\overline{RENA2}$ ($\overline{RENB2}$) are asserted.
$\overline{RENA1}$ $\overline{RENB1}$	Read Enable 1	I	When $\overline{RENA1}$ ($\overline{RENB1}$) and $\overline{RENA2}$ ($\overline{RENB2}$) are LOW, data is read from FIFO A (B) on every LOW-to-HIGH transition of RCLKA (RCLKB). Data will not be read from Array A (B) if \overline{EFA} (\overline{EFB}) is LOW.
$\overline{RENA2}$ $\overline{RENB2}$	Read Enable 2	I	When $\overline{RENA1}$ ($\overline{RENB1}$) and $\overline{RENA2}$ ($\overline{RENB2}$) are LOW, data is read from the FIFO A (B) on every LOW-to-HIGH transition of RCLKA (RCLKB). Data will not be read from array A (B) if the \overline{EFA} (\overline{EFB}) is LOW.
\overline{OEA} \overline{OEB}	Output Enable	I	When \overline{OEA} (\overline{OEB}) is LOW, outputs DA0-DA8 (DB0-DB8) are active. If \overline{OEA} (\overline{OEB}) is HIGH, the outputs DA0-DA8 (DB0-DB8) will be in a high-impedance state.
\overline{EFA} \overline{EFB}	Empty Flag	O	When \overline{EFA} (\overline{EFB}) is LOW, FIFO A (B) is empty and further data reads from the output are inhibited. When \overline{EFA} (\overline{EFB}) is HIGH, FIFO A (B) is not empty. \overline{EFA} (\overline{EFB}) is synchronized to RCLKA (RCLKB).
\overline{PAEA} \overline{PAEB}	Programmable Almost-Empty Flag	O	When \overline{PAEA} (\overline{PAEB}) is LOW, FIFO A (B) is almost-empty based on the offset programmed into the appropriate offset register. The default offset at reset is Empty+7. \overline{PAEA} (\overline{PAEB}) is synchronized to RCLKA (RCLKB).
\overline{PAFA} \overline{PAFB}	Programmable Almost-Full Flag	O	When \overline{PAFA} (\overline{PAFB}) is LOW, FIFO A (B) is almost-full based on the offset programmed into the appropriate offset register. The default offset at reset is Full-7. \overline{PAFA} (\overline{PAFB}) is synchronized to WCLKA (WCLKB).
\overline{FFA} \overline{FFB}	Full Flag	O	When \overline{FFA} (\overline{FFB}) is LOW, FIFO A (B) is full and further data writes into the input are inhibited. When \overline{FFA} (\overline{FFB}) is HIGH, FIFO A (B) is not full. \overline{FFA} (\overline{FFB}) is synchronized to WCLKA (WCLKB).
VCC	Power		+5V power supply pin.
GND	Ground		0V ground pin.

ABSOLUTE MAXIMUM RATINGS

Symbol	Rating	Com'l & Ind'l	Unit
VTERM	Terminal Voltage with Respect to GND	-0.5 to +7.0	V
TSTG	Storage Temperature	-55 to +125	°C
IOUT	DC Output Current	-50 to +50	mA

NOTE:

- Stresses greater than those listed under ABSOLUTE MAXIMUM RATINGS may cause permanent damage to the device. This is a stress rating only and functional operation of the device at these or any other conditions above those indicated in the operational sections of the specification is not implied. Exposure to absolute maximum rating conditions for extended periods may affect reliability.

RECOMMENDED OPERATING CONDITIONS

Symbol	Parameter	Min.	Typ.	Max.	Unit
VCC	Supply Voltage (Com'l & Ind'l)	4.5	5.0	5.5	V
GND	Supply Voltage (Com'l & Ind'l)	0	0	0	V
V _{IH}	Input High Voltage (Com'l & Ind'l)	2.0	—	—	V
V _{IL}	Input Low Voltage (Com'l & Ind'l)	—	—	0.8	V
T _A	Operating Temperature Commercial	0	—	70	°C
T _A	Operating Temperature Industrial	-40	—	85	°C

DC ELECTRICAL CHARACTERISTICS

(Commercial: VCC = 5V ± 10%, TA = 0°C to +70°C; Industrial: VCC = 5V ± 10%, TA = -40°C to +85°C)

Symbol	Parameter	IDT72801 IDT72811 IDT72821 IDT72831 IDT72841 Commercial and Industrial ⁽¹⁾ t _{CLK} = 10, 15, 25 ns			IDT72851 Commercial and Industrial ⁽¹⁾ t _{CLK} = 10, 15, 25 ns			Unit
		Min.	Typ.	Max.	Min.	Typ.	Max.	
I _{LI} ⁽²⁾	Input Leakage Current (Any Input)	-1	—	1	-1	—	1	μA
I _{LO} ⁽³⁾	Output Leakage Current	-10	—	10	-10	—	10	μA
V _{OH}	Output Logic "1" Voltage, I _{OH} = -2 mA	2.4	—	—	2.4	—	—	V
V _{OL}	Output Logic "0" Voltage, I _{OL} = 8 mA	—	—	0.4	—	—	0.4	V
I _{CC1} ^(4,5,6,8)	Active Power Supply Current (both FIFOs)	—	—	60	—	—	80	mA
I _{CC2} ^(4,7,8)	Standby Current	—	—	10	—	—	10	mA

NOTES:

- Industrial temperature range product for 15ns and 25ns speed grade are available as a standard device.
- Measurements with $0.4 \leq V_{IN} \leq V_{CC}$.
- $\overline{OE} \geq V_{IH}$, $0.4 \leq V_{OUT} \leq V_{CC}$.
- Tested with outputs open (I_{OUT} = 0).
- RCLK and WCLK toggle at 20 MHz and data inputs switch at 10 MHz.
- Typical I_{CC1} = 2*[1.7 + 0.7*fs + 0.02*CL*fs] (in mA).
 These equations are valid under the following conditions:
 V_{CC} = 5V, T_A = 25°C, fs = WCLK frequency = RCLK frequency (in MHz, using TTL levels), data switching at fs/2, CL = capacitive load (in pF).
- All Inputs = V_{CC} - 0.2V or GND + 0.2V, except RCLK and WCLK, which toggle at 20 MHz.
- I_{CC1} and I_{CC2} parameters are improved as compared to previous data sheets.

CAPACITANCE (TA = +25°C, f = 1.0MHz)

Symbol	Parameter	Conditions	Max.	Unit
C _{IN} ⁽²⁾	Input Capacitance	V _{IN} = 0V	10	pF
C _{OUT} ^(1,2)	Output Capacitance	V _{OUT} = 0V	10	pF

NOTE:

- With output deselected (\overline{OE} , $\overline{OEB} \geq V_{IH}$).
- Characterized values, not currently tested.

AC ELECTRICAL CHARACTERISTICS

(Commercial: VCC = 5V ± 10%, TA = 0°C to +70°C; Industrial: VCC = 5V ± 10%, TA = -40°C to +85°C)

Symbol	Parameter	Commercial		Com'l & Ind'l ⁽¹⁾				Unit
		Min	Max.	Min	Max.	Min	Max.	
				IDT72801L10	IDT72801L15	IDT72801L25		
				IDT72811L10	IDT72811L15	IDT72811L25		
				IDT72821L10	IDT72821L15	IDT72821L25		
				IDT72831L10	IDT72831L15	IDT72831L25		
				IDT72841L10	IDT72841L15	IDT72841L25		
				IDT72851L10	IDT72851L15	IDT72851L25		
fs	Clock Cycle Frequency	—	100	—	66.7	—	40	MHz
ta	Data Access Time	2	6.5	2	10	2	15	ns
tCLK	Clock Cycle Time	10	—	15	—	25	—	ns
tCLKH	Clock High Time	4.5	—	6	—	10	—	ns
tCLKL	Clock Low Time	4.5	—	6	—	10	—	ns
tDS	Data Setup Time	3	—	4	—	6	—	ns
tDH	Data Hold Time	0.5	—	1	—	1	—	ns
tENS	Enable Setup Time	3	—	4	—	6	—	ns
tENH	Enable Hold Time	0.5	—	1	—	1	—	ns
tRS	Reset Pulse Width ⁽²⁾	10	—	15	—	15	—	ns
tRSS	Reset Setup Time	8	—	10	—	15	—	ns
tRSR	Reset Recovery Time	8	—	10	—	15	—	ns
tRSF	Reset to Flag Time and Output Time	—	10	—	15	—	25	ns
tOLZ	Output Enable to Output in Low-Z ⁽³⁾	0	—	0	—	0	—	ns
tOE	Output Enable to Output Valid	3	6	3	8	3	13	ns
tOHZ	Output Enable to Output in High-Z ⁽³⁾	3	6	3	8	3	13	ns
tWFF	Write Clock to Full Flag	—	6.5	—	10	—	15	ns
tREF	Read Clock to Empty Flag	—	6.5	—	10	—	15	ns
tPAF	Write Clock to Programmable Almost-Full Flag	—	6.5	—	10	—	15	ns
tPAE	Read Clock to Programmable Almost-Empty Flag	—	6.5	—	10	—	15	ns
tSKEW1	Skew Time Between Read Clock and Write Clock for Empty Flag and Full Flag	5	—	6	—	10	—	ns
tSKEW2	Skew Time Between Read Clock and Write Clock for Programmable Almost-Empty Flag and Programmable Almost-Full Flag	14	—	15	—	18	—	ns

NOTES:

1. Industrial temperature range product for 15ns and 25ns speed grade are available as a standard device.
2. Pulse widths less than minimum values are not allowed.
3. Values guaranteed by design, not currently tested.

AC TEST CONDITIONS

In Pulse Levels	GND to 3.0V
Input Rise/Fall Times	3ns
Input Timing Reference Levels	1.5V
Output Reference Levels	1.5V
Output Load	See Figure 1

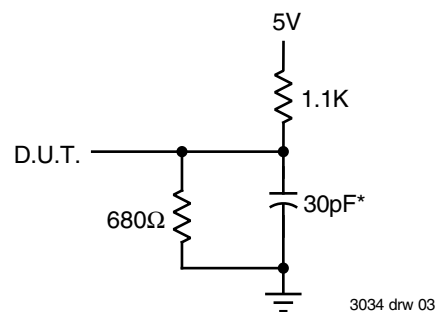

or equivalent circuit
Figure 1. Output Load
 *Includes jig and scope capacitances.

3034 drw 03

SIGNAL DESCRIPTIONS

FIFO A and FIFO B are identical in every respect. The following description explains the interaction of input and output signals for FIFO A. The corresponding signal names for FIFO B are provided in parentheses.

INPUTS:

Data In (DA0–DA8, DB0–DB8) — DA0 - DA8 are the nine data inputs for memory array A. DB0 - DB8 are the nine data inputs for memory array B.

CONTROLS:

Reset (\overline{RSA} , \overline{RSB}) — Reset of FIFO A (B) is accomplished whenever \overline{RSA} (\overline{RSB}) input is taken to a LOW state. During Reset, the internal read and write pointers associated with the FIFO are set to the first location. A Reset is required after power-up before a write operation can take place. The Full Flag \overline{FFA} (\overline{FFB}) and Programmable Almost-Full flag \overline{PAFA} (\overline{PAFB}) will be reset to HIGH after tRSF. The Empty Flag \overline{EFA} (\overline{EFB}) and Programmable Almost-Empty flag \overline{PAEA} (\overline{PAEB}) will be reset to LOW after tRSF. During Reset, the output register is initialized to all zeros and the offset registers are initialized to their default values.

Write Clock (WCLKA, WCLKB) — A write cycle to Array A (B) is initiated on the LOW-to-HIGH transition of WCLKA (WCLKB). Data setup and hold times must be met with respect to the LOW-to-HIGH transition of WCLKA (WCLKB). The Full Flag \overline{FFA} (\overline{FFB}) and Programmable Almost-Full flag \overline{PAFA} (\overline{PAFB}) are synchronized with respect to the LOW-to-HIGH transition of the Write Clock WCLKA (WCLKB).

The Write and Read Clocks can be asynchronous or coincident.

Write Enable 1 ($\overline{WENA1}$, $\overline{WENB1}$) — If FIFO A (B) is configured for programmable flags, $\overline{WENA1}$ ($\overline{WENB1}$) is the only enable control pin. In this configuration, when $\overline{WENA1}$ ($\overline{WENB1}$) is LOW, data can be loaded into the input register of RAM Array A (B) on the LOW-to-HIGH transition of every Write Clock WCLKA (WCLKB). Data is stored in Array A (B) sequentially and independently of any ongoing read operation.

In this configuration, when $\overline{WENA1}$ ($\overline{WENB1}$) is HIGH, the input register holds the previous data and no new data is allowed to be loaded into the register.

If the FIFO is configured to have two write enables, which allows for depth expansion. See Write Enable 2 paragraph below for operation in this configuration.

To prevent data overflow, \overline{FFA} (\overline{FFB}) will go LOW, inhibiting further write operations. Upon the completion of a valid read cycle, the \overline{FFA} (\overline{FFB}) will go HIGH after tWFF, allowing a valid write to begin. $\overline{WENA1}$ ($\overline{WENB1}$) is ignored when FIFO A (B) is full.

Read Clock (RCLKA, RCLKB) — Data can be read from Array A (B) on the LOW-to-HIGH transition of RCLKA (RCLKB). The Empty Flag \overline{EFA} (\overline{EFB}) and Programmable Almost-Empty Flag \overline{PAEA} (\overline{PAEB}) are synchronized with respect to the LOW-to-HIGH transition of RCLKA (RCLKB).

The Write and Read Clocks can be asynchronous or coincident.

Read Enables ($\overline{RENA1}$, $\overline{RENA2}$, $\overline{RENB1}$, $\overline{RENB2}$) — When both Read Enables $\overline{RENA1}$, $\overline{RENA2}$ ($\overline{RENB1}$, $\overline{RENB2}$) are LOW, data is read from Array A (B) to the output register on the LOW-to-HIGH transition of the Read Clock RCLKA (RCLKB).

When either of the two Read Enable $\overline{RENA1}$, $\overline{RENA2}$ ($\overline{RENB1}$, $\overline{RENB2}$) associated with FIFO A (B) is HIGH, the output register holds the previous data and no new data is allowed to be loaded into the register.

When all the data has been read from FIFO A (B), the Empty Flag \overline{EFA} (\overline{EFB}) will go LOW, inhibiting further read operations. Once a valid write operation has been accomplished, \overline{EFA} (\overline{EFB}) will go HIGH after tREF and a valid read can begin. The Read Enables $\overline{RENA1}$, $\overline{RENA2}$ ($\overline{RENB1}$, $\overline{RENB2}$) are ignored when FIFO A (B) is empty.

Output Enable (\overline{OEA} , \overline{OEB}) — When Output Enable \overline{OEA} (\overline{OEB}) is enabled (LOW), the parallel output buffers of FIFO A (B) receive data from their respective output register. When Output Enable \overline{OEA} (\overline{OEB}) is disabled (HIGH), the QA (QB) output data bus is in a high-impedance state.

Write Enable 2/Load ($\overline{WENA2/LDA}$, $\overline{WENB2/LDB}$) — This is a dual-purpose pin. FIFO A (B) is configured at Reset to have programmable flags or to have two write enables, which allows depth expansion. If $\overline{WENA2/LDA}$ ($\overline{WENB2/LDB}$) is set HIGH at Reset $\overline{RSA} = \text{LOW}$ ($\overline{RSB} = \text{LOW}$), this pin operates as a second write enable pin.

If FIFO A (B) is configured to have two write enables, when Write Enable 1 $\overline{WENA1}$ ($\overline{WENB1}$) is LOW and $\overline{WENA2/LDA}$ ($\overline{WENB2/LDB}$) is HIGH, data can be loaded into the input register and RAM array on the LOW-to-HIGH transition of every Write Clock WCLKA (WCLKB). Data is stored in the array sequentially and independently of any ongoing read operation.

In this configuration, when $\overline{WENA1}$ ($\overline{WENB1}$) is HIGH and/or $\overline{WENA2/LDA}$ ($\overline{WENB2/LDB}$) is LOW, the input register of Array A holds the previous data and no new data is allowed to be loaded into the register.

To prevent data overflow, the Full Flag \overline{FFA} (\overline{FFB}) will go LOW, inhibiting further write operations. Upon the completion of a valid read cycle, \overline{FFA} (\overline{FFB}) will go HIGH after tWFF, allowing a valid write to begin. $\overline{WENA1}$, ($\overline{WENB1}$) and $\overline{WENA2/LDA}$ ($\overline{WENB2/LDB}$) are ignored when the FIFO is full.

FIFO A (B) is configured to have programmable flags when the $\overline{WENA2/LDA}$ ($\overline{WENB2/LDB}$) is set LOW at Reset $\overline{RSA} = \text{LOW}$ ($\overline{RSB} = \text{LOW}$). Each FIFO contains four 8-bit offset registers which can be loaded with data on the inputs, or read on the outputs. See Figure 3 for details of the size of the registers and the default values.

If FIFO A (B) is configured to have programmable flags, when the $\overline{WENA1}$ ($\overline{WENB1}$) and $\overline{WENA2/LDA}$ ($\overline{WENB2/LDB}$) are set LOW, data on the DA (DB) inputs are written into the Empty (Least Significant Bit) Offset register on the first LOW-to-HIGH transition of the WCLKA (WCLKB). Data are written into the Empty (Most Significant Bit) Offset register on the second LOW-to-HIGH transition of WCLKA (WCLKB), into the Full (Least Significant Bit) Offset register on the third transition, and into the Full (Most Significant Bit) Offset register on the fourth transition. The fifth transition of WCLKA (WCLKB) again writes to the Empty (Least Significant Bit) Offset register.

However, writing all offset registers does not have to occur at one time. One or two offset registers can be written and then by bringing \overline{LDA} (\overline{LDB}) HIGH, FIFO A (B) is returned to normal read/write operation. When \overline{LDA} (\overline{LDB}) is set LOW, and $\overline{WENA1}$ ($\overline{WENB1}$) is LOW, the next offset register in sequence is written.

The contents of the offset registers can be read on the QA (QB) outputs when $\overline{WENA2/LDA}$ ($\overline{WENB2/LDB}$) is set LOW and both Read Enables $\overline{RENA1}$, $\overline{RENA2}$ ($\overline{RENB1}$, $\overline{RENB2}$) are set LOW. Data can be read on the LOW-to-HIGH transition of the Read Clock RCLKA (RCLKB).

LDA	WENA1	WCLKA	OPERATION ON FIFO A
LDB	WENB1	WCLKB	OPERATION ON FIFO B
0	0		Empty Offset (LSB) Empty Offset (MSB) Full Offset (LSB) Full Offset (MSB)
0	1		No Operation
1	0		Write Into FIFO
1	1		No Operation

A read and write should not be performed simultaneously to the offset registers.

OUTPUTS:

Full Flag (\overline{FFA} , \overline{FFB}) — \overline{FFA} (\overline{FFB}) will go LOW, inhibiting further write operations, when Array A (B) is full. If no reads are performed after reset, \overline{FFA} (\overline{FFB}) will go LOW after 256 writes to the IDT72801's FIFO A (B); 512 writes to the IDT72811's FIFO A (B); 1,024 writes to the IDT72821's FIFO A (B); 2,048 writes to the IDT72831's FIFO A (B); 4,096 writes to the IDT72841's FIFO A (B); or 8,192 writes to the IDT72851's FIFO A (B).

\overline{FFA} (\overline{FFB}) is synchronized with respect to the LOW-to-HIGH transition of the Write Clock WCLKA (WCLKB).

Empty Flag (\overline{EFA} , \overline{EFB}) — EFA (EFB) will go LOW, inhibiting further read operations, when the read pointer is equal to the write pointer, indicating that Array A (B) is empty.

\overline{EFA} (\overline{EFB}) is synchronized with respect to the LOW-to-HIGH transition of the Read Clock RCLKA (RCLKB).

NOTE:

- For the purposes of this table, WENA2 and WENB2 = VIH.
- The same selection sequence applies to reading from the registers. $\overline{RENA1}$ and $\overline{RENA2}$ ($\overline{RENB1}$ and $\overline{RENB2}$) are enabled and read is performed on the LOW-to-HIGH transition of RCLKA (RCLKB).

Figure 2. Writing to Offset Registers for FIFOs A and B

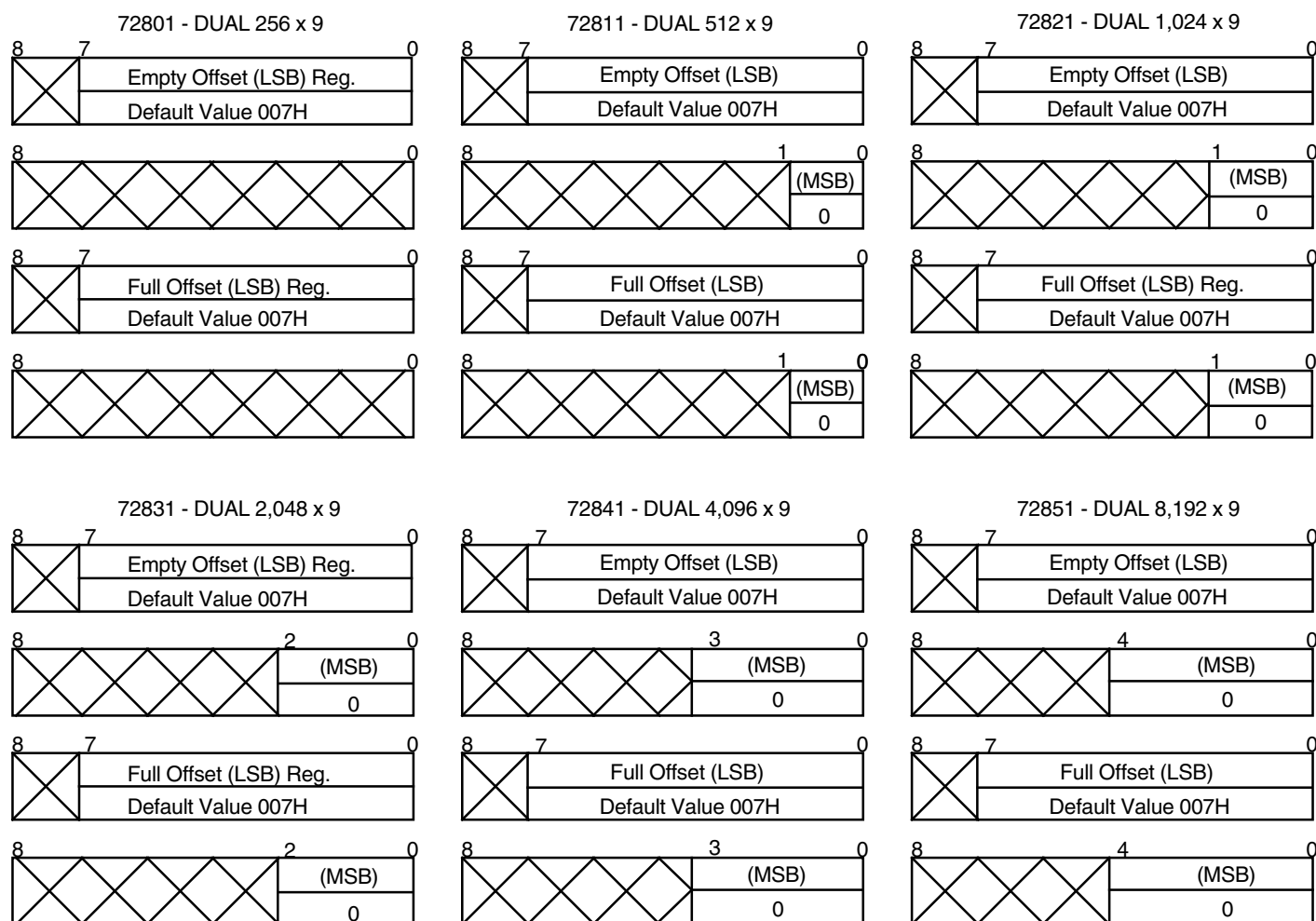

3034 drw 04

Figure 3. Offset Register Formats and Default Values for the A and B FIFOs

Programmable Almost-Full Flag (**PAFA, PAFB**) — \overline{PAFA} (\overline{PAFB}) will go LOW when the amount of data in Array A (B) reaches the almost-full condition. If no reads are performed after Reset, \overline{PAFA} (\overline{PAFB}) will go LOW after (256-m) writes to the IDT72801's FIFO A (B); (512-m) writes to the IDT72811's FIFO A (B); (1,024-m) writes to the IDT72821's FIFO A (B); (2,048-m) writes to the IDT72831's FIFO A (B); (4,096-m) writes to the IDT72841's FIFO A (B); or (8,192-m) writes to the IDT72851's FIFO A (B).

FFA (FFB) is synchronized with respect to the LOW-to-HIGH transition of the Write Clock WCLKA (WCLKB). The offset "m" is defined in the Full Offset registers.

If there is no Full offset specified, \overline{PAFA} (\overline{PAFB}) will go LOW at Full-7 words.

\overline{PAFA} (\overline{PAFB}) is synchronized with respect to the LOW-to-HIGH transition of WCLKA (WCLKB).

Programmable Almost-Empty Flag (**PAEA, PAEB**) — \overline{PAEA} (\overline{PAEB}) will go LOW when the read pointer is "n+1" locations less than the write pointer. The offset "n" is defined in the Empty Offset registers. If no reads are performed after Reset, \overline{PAEA} (\overline{PAEB}) will go HIGH after "n+1" writes to FIFO A (B).

If there is no Empty offset specified, \overline{PAEA} (\overline{PAEB}) will go LOW at Empty+7 words.

\overline{PAEA} (\overline{PAEB}) is synchronized with respect to the LOW-to-HIGH transition of the Read Clock RCLKA (RCLKB).

Data Outputs (QA0 – QA8, QB0 – QB8) — QA0 - QA8 are the nine data outputs for memory array A, QB0 - QB8 are the nine data outputs for memory array B.

TABLE 1: STATUS FLAGS FOR A AND B FIFOS

NUMBER OF WORDS IN ARRAY A			FFA	PAFA	PAEA	EFA
NUMBER OF WORDS IN ARRAY B			FFB	PAFB	PAEB	EFB
72801	72811	72821				
0	0	0	H	H	L	L
1 to n ⁽¹⁾	1 to n ⁽¹⁾	1 to n ⁽¹⁾	H	H	L	H
(n+1) to (256-(m+1))	(n+1) to (512-(m+1))	(n+1) to (1,024-(m+1))	H	H	H	H
(256-m) ⁽²⁾ to 255	(512-m) ⁽²⁾ to 511	(1,024-m) ⁽²⁾ to 1,023	H	L	H	H
256	512	1,024	L	L	H	H

NUMBER OF WORDS IN ARRAY A			FFA	PAFA	PAEA	EFA
NUMBER OF WORDS IN ARRAY B			FFB	PAFB	PAEB	EFB
72831	72841	72851				
0	0	0	H	H	L	L
1 to n ⁽¹⁾	1 to n ⁽¹⁾	1 to n ⁽¹⁾	H	H	L	H
(n+1) to (2,048-(m+1))	(n+1) to (4,096-(m+1))	(n+1) to (8,192-(m+1))	H	H	H	H
(2,048-m) ⁽²⁾ to 2,047	(4,096-m) ⁽²⁾ to 4,095	(8,192-m) ⁽²⁾ to 8,191	H	L	H	H
2,048	4,096	8,192	L	L	H	H

NOTES:

1. n = Empty Offset (n = 7 default value)
2. m = Full Offset (m = 7 default value)

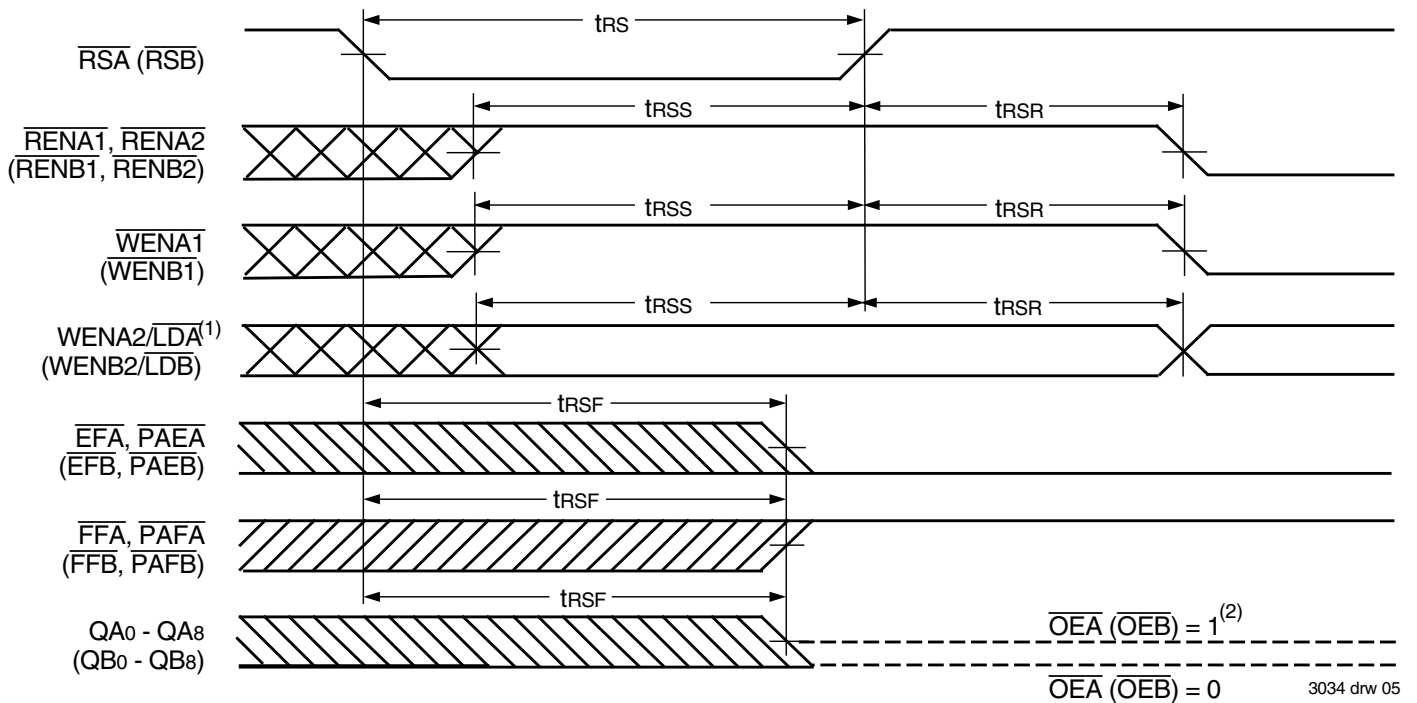

3034 drw 05

NOTES:

1. Holding $WENA2/\overline{LDA}$ ($WENB2/\overline{LDB}$) HIGH during reset will make the pin act as a second write enable pin. Holding $WENA2/\overline{LDA}$ ($WENB2/\overline{LDB}$) LOW during reset will make the pin act as a load enable for the programmable flag offset registers.
2. After reset, $QA0 - QA8$ ($QB0 - QB8$) will be LOW if OEA (OEB) = 0 and tri-state if OEA (OEB) = 1.
3. The clocks $RCLKA$, $WCLKA$ ($RCLKB$, $WCLKB$) can be free-running during reset.

Figure 4. Reset Timing

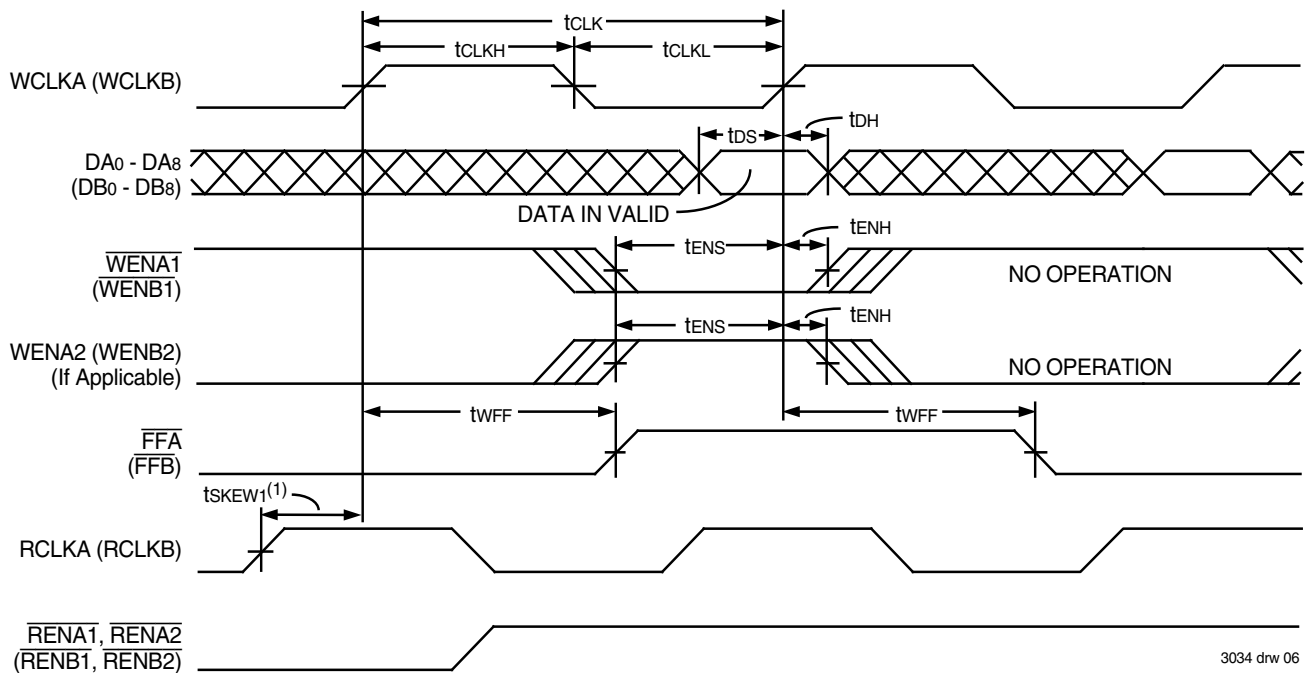

3034 drw 06

NOTE:

1. t_{sKEW1} is the minimum time between a rising $RCLKA$ ($RCLKB$) edge and a rising $WCLKA$ ($WCLKB$) edge for \overline{FFA} (\overline{FFB}) to change during the current clock cycle. If the time between the rising edge of $RCLKA$ ($RCLKB$) and the rising edge of $WCLKA$ ($WCLKB$) is less than t_{sKEW1} , then \overline{FFA} (\overline{FFB}) may not change state until the next $WCLKA$ ($WCLKB$) edge.

Figure 5. Write Cycle Timing

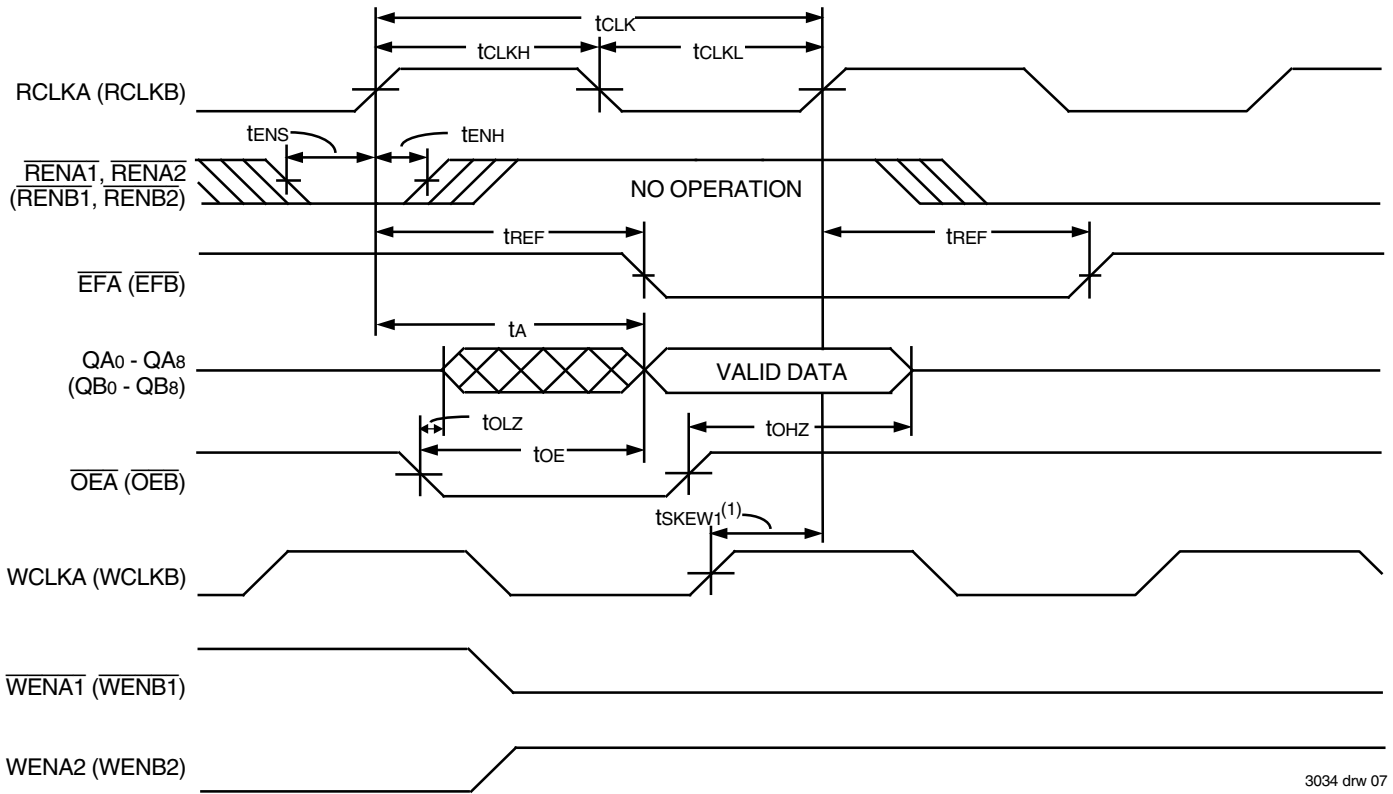

3034 drw 07

- NOTE:
- t_{SKEW1} is the minimum time between a rising WCLKA (WCLKB) edge and a rising RCLKA (RCLKB) edge for \overline{EFA} (\overline{EFB}) to change during the current clock cycle. If the time between the rising edge of RCLKA (RCLKB) and the rising edge of WCLKA (WCLKB) is less than t_{SKEW1} , then \overline{EFA} (\overline{EFB}) may not change state until the next RCLKA (RCLKB)

Figure 6. Read Cycle Timing

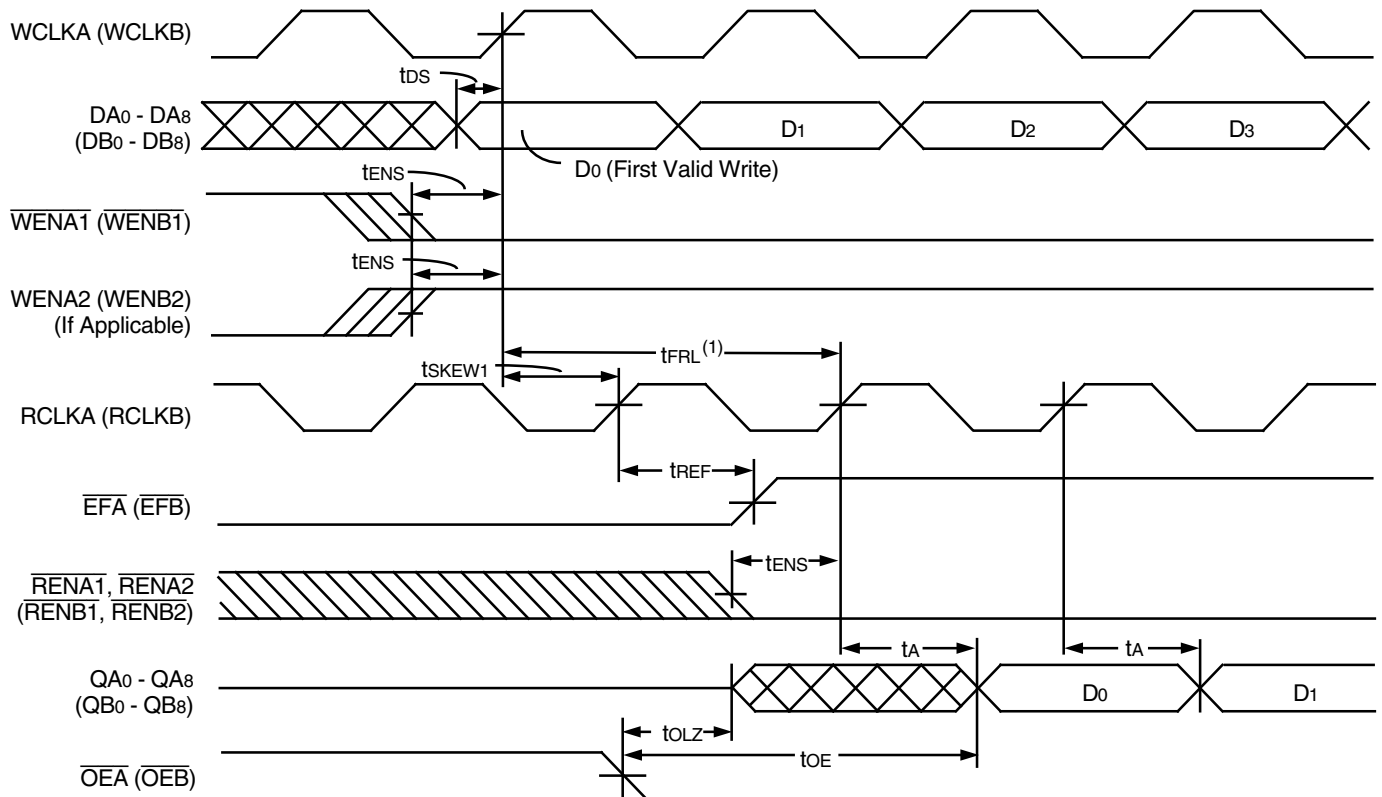

3034 drw 08

- NOTE:
- When $t_{SKEW1} \geq$ minimum specification, $t_{FRL} = t_{CLK} + t_{SKEW1}$
 When $t_{SKEW1} <$ minimum specification, $t_{FRL} = 2t_{CLK} + t_{SKEW1V}$ or $t_{CLK} + t_{SKEW1}$
 The Latency Timings apply only at the Empty Boundary (\overline{EFA} , $\overline{EFB} =$ LOW).

Figure 7. First Data Word Latency Timing

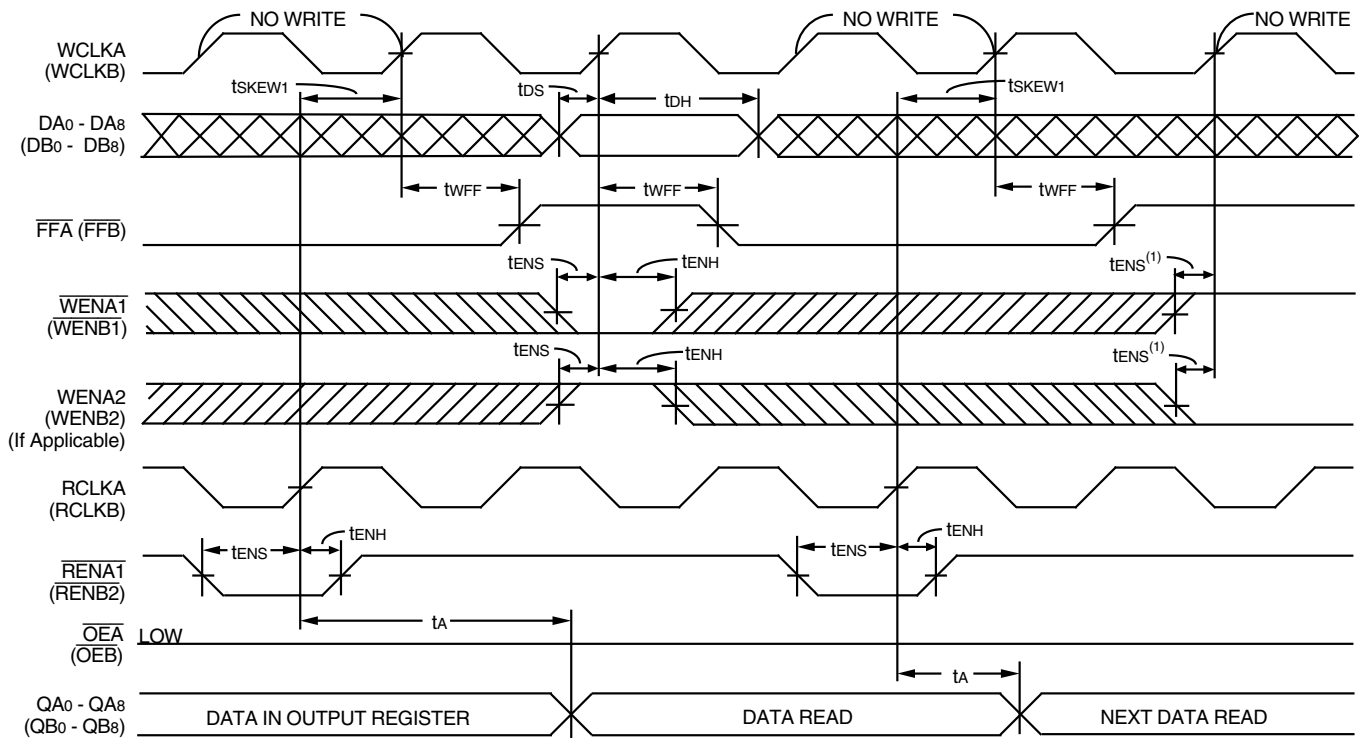

3034 drw 09

NOTE:

- Only one of the two write enable inputs, $\overline{WEN1}$ or $\overline{WEN2}$, needs to go inactive to inhibit writes to the FIFO.

Figure 8. Full Flag Timing

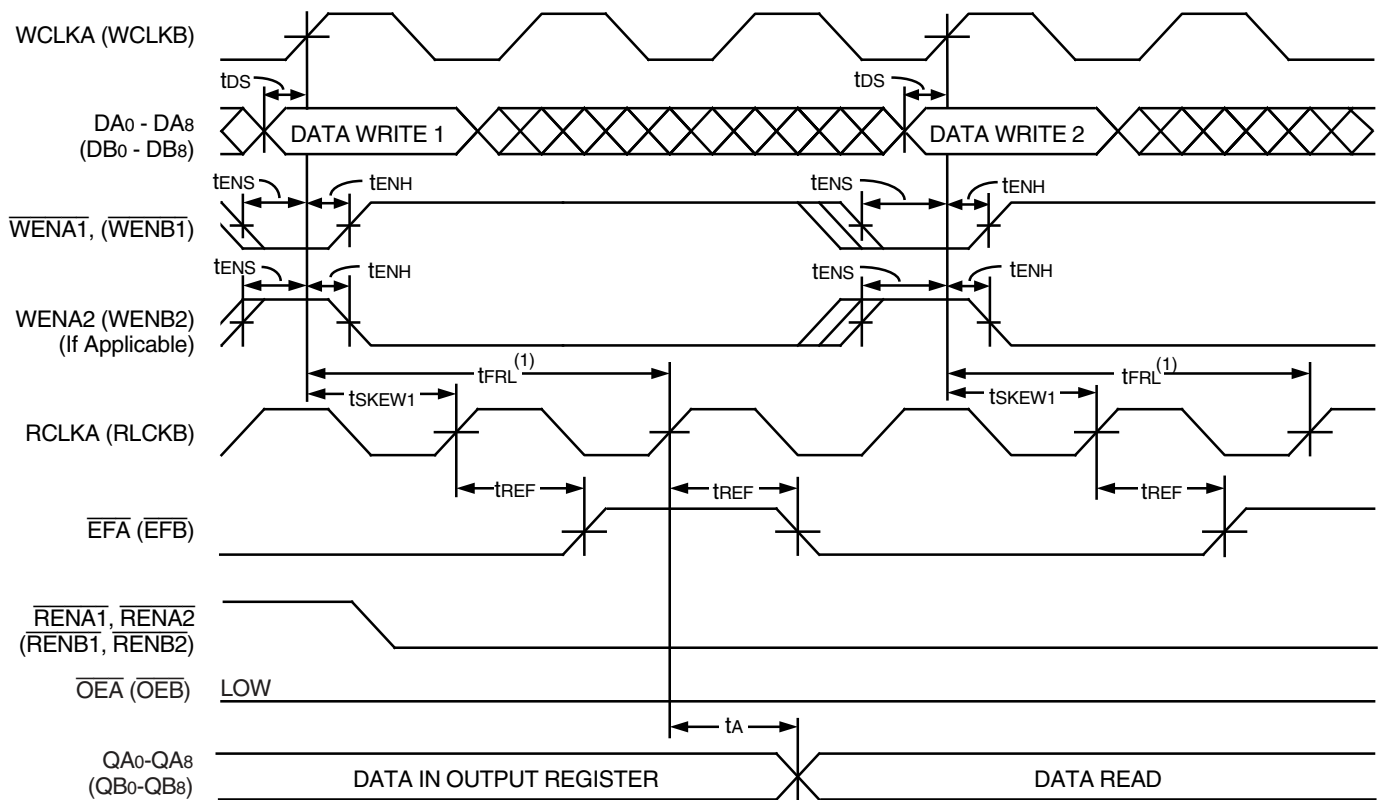

3034 drw 10

NOTE:

- When $t_{sKEW1} \geq$ minimum specification, t_{FRL} maximum = $t_{CLK} + t_{sKEW1}$
 When $t_{sKEW1} <$ minimum specification, t_{FRL} maximum = $2t_{CLK} + t_{sKEW1}$ or $t_{CLK} + t_{sKEW1}$
 The Latency Timings apply only at the Empty Boundary (\overline{EFA} , $\overline{EFB} = \text{LOW}$).

Figure 9. Empty Flag Timing

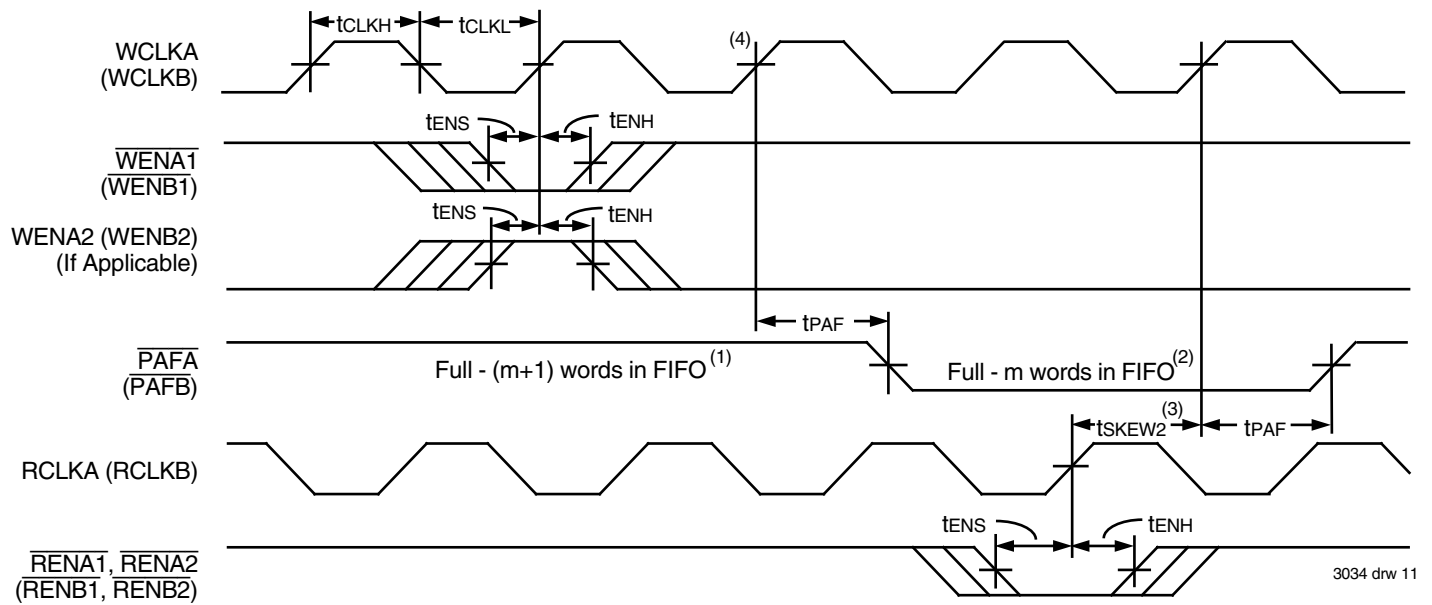

NOTES:

- $m = \overline{PAF}$ offset.
- (256-m) words for the IDT72801; (512-m) words for the IDT72811; (1,024-m) words for the IDT72821; (2,048-m) words for the IDT72831; (4,096-m) words for the IDT72841; or (8,192-m) words for the IDT72851.
- t_{SKEW2} is the minimum time between a rising RCLKA (RCLKB) edge and a rising WCLKA (WCLKB) edge for \overline{PAFA} (\overline{PAFB}) to change during that clock cycle. If the time between the rising edge of RCLKA (RCLKB) and the rising edge of WCLKA (WCLKB) is less than t_{SKEW2} , then \overline{PAFA} (\overline{PAFB}) may not change state until the next WCLKA (WCLKB) rising edge.
- If a write is performed on this rising edge of the write clock, there will be Full - (m-1) words in FIFO A (B) when \overline{PAFA} (\overline{PAFB}) goes LOW.

Figure 10. Programmable Full Flag Timing

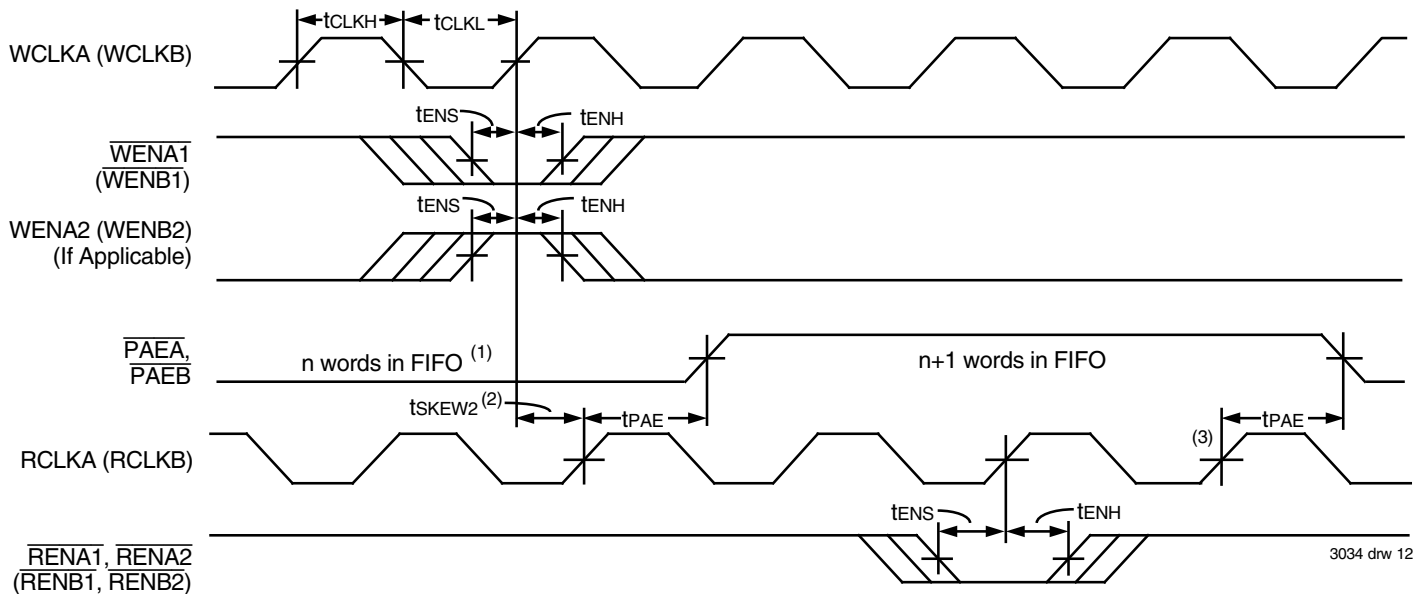

NOTES:

- $n = \overline{PAE}$ offset.
- t_{SKEW2} is the minimum time between a rising WCLKA (WCLKB) edge and a rising RCLKA (RCLKB) edge for \overline{PAEA} (\overline{PAEB}) to change during that clock cycle. If the time between the rising edge of WCLKA (WCLKB) and the rising edge of RCLKA (RCLKB) is less than t_{SKEW2} , then \overline{PAEA} (\overline{PAEB}) may not change state until the next RCLKA (RCLKB) rising edge.
- If a read is performed on this rising edge of the read clock, there will be Empty + (n-1) words in FIFO A (B) when \overline{PAEA} (\overline{PAEB}) goes LOW.

Figure 11. Programmable Empty Flag Timing

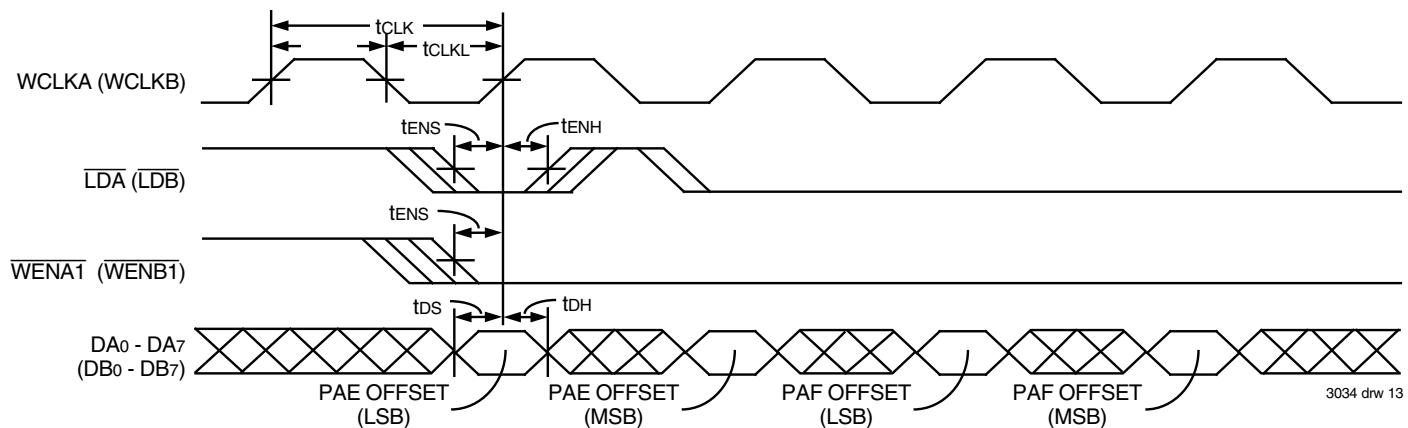

Figure 12. Write Offset Register Timing

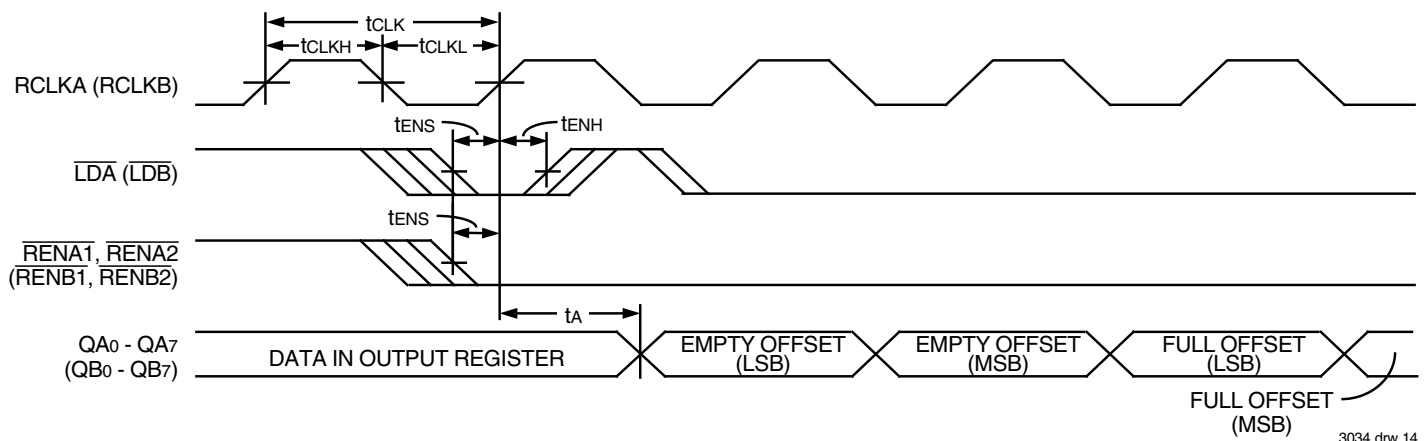
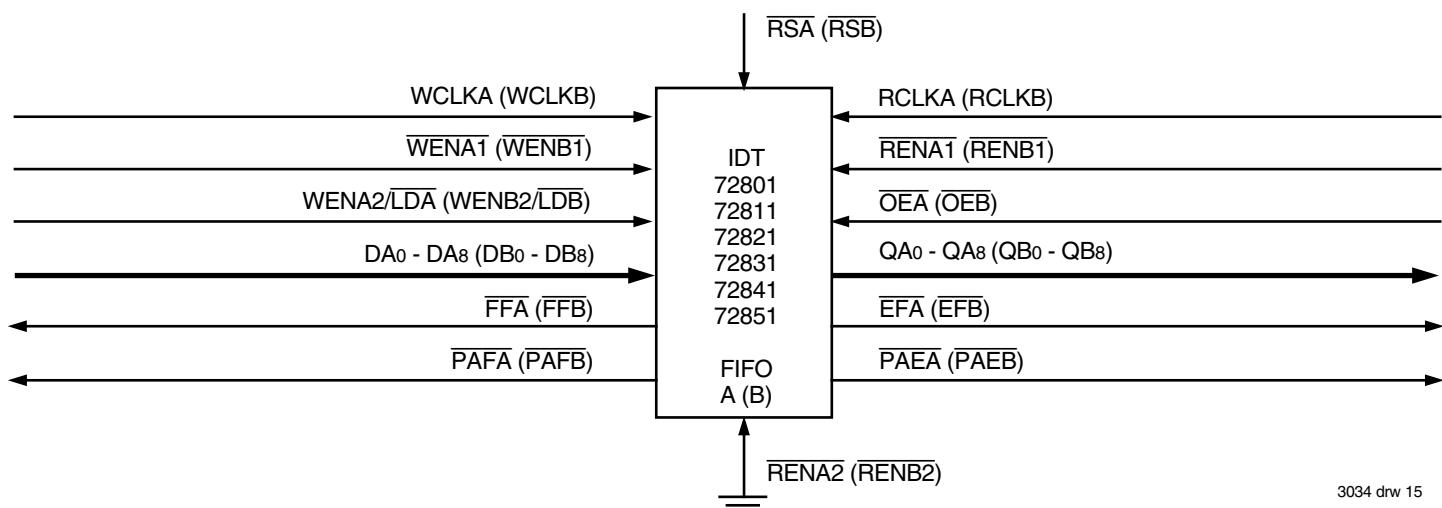

Figure 13. Read Offset Register Timing

OPERATING CONFIGURATIONS

SINGLE DEVICE CONFIGURATION — When FIFO A (B) is in a Single Device Configuration, the Read Enable 2 $\overline{\text{RENA2}}$ ($\overline{\text{RENB2}}$) control input

can be grounded (see Figure 14). In this configuration, the Write Enable 2/ Load $\text{WENA2}/\overline{\text{LDA}}$ ($\text{WENB2}/\overline{\text{LDB}}$) pin is set LOW at Reset so that the pin operates as a control to load and read the programmable flag offsets.



3034 drw 15

Figure 14. Block Diagram of One of the IDT72801/72811/72821/72831/72841/72851's two FIFOs configured as a single device

WIDTH EXPANSION CONFIGURATION — Word width may be increased simply by connecting the corresponding input control signals of FIFOs A and B. A composite flag should be created for each of the endpoint status flags $\overline{\text{EFA}}$ and $\overline{\text{EFB}}$, also $\overline{\text{FFA}}$ and $\overline{\text{FFB}}$. The partial status flags $\overline{\text{PAEA}}$, $\overline{\text{PAFB}}$, $\overline{\text{PAEA}}$ and $\overline{\text{PAFB}}$ can be detected from any one device. Figure 15 demonstrates an 18-bit word width using the two FIFOs contained in one IDT72801/72811/72821/72831/72841/72851. Any word width can

be attained by adding additional IDT72801/72811/72821/72831/72841/72851s.

When these devices are in a Width Expansion Configuration, the Read Enable 2 ($\overline{\text{RENA2}}$ and $\overline{\text{RENB2}}$) control inputs can be grounded (see Figure 15). In this configuration, the Write Enable 2/Load ($\text{WENA2}/\overline{\text{LDA}}$, $\text{WENB2}/\overline{\text{LDB}}$) pins are set LOW at Reset so that the pin operates as a control to load and read the programmable flag offsets.

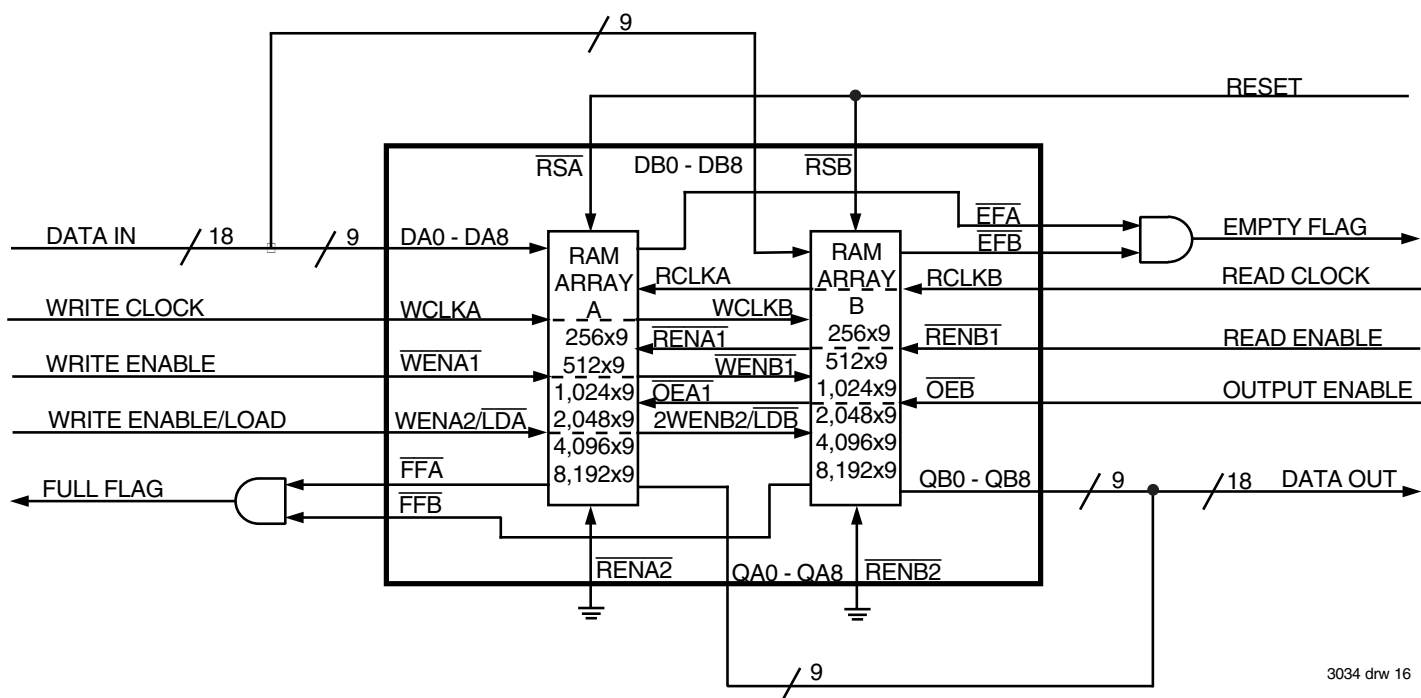

3034 drw 16

Figure 15. Block diagram of the two FIFOs contained in one IDT72801/72811/72821/72831/72841/72851 configured for an 18-bit width-expansion

TWO PRIORITY DATA BUFFER CONFIGURATION

The two FIFOs contained in the IDT72801/72811/72821/72831/72841/72851 can be used to prioritize two different types of data shared on a system bus. When writing from the bus to the FIFO, control logic sorts the intermixed data

according to type, sending one kind to FIFO A and the other kind to FIFO B. Then, at the outputs, each data type is transferred to its appropriate destination. Additional IDT72801/72811/72821/72831/72841/72851s permit more than two priority levels. Priority buffering is particularly useful in network applications.

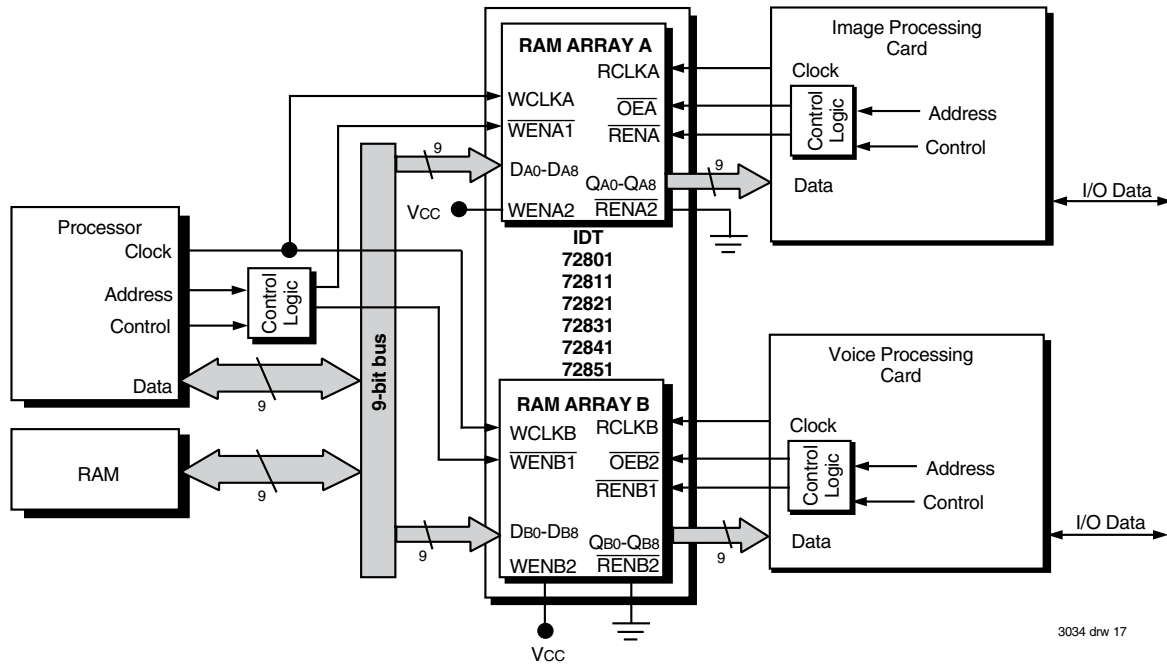

Figure 16. Block Diagram of Two Priority Configuration

BIDIRECTIONAL CONFIGURATION

The two FIFOs of the IDT72801/72811/72821/72831/72841/72851 can be used to buffer data flow in two directions. In the example that follows, a

processor can write data to a peripheral controller via FIFO A, and, in turn, the peripheral controller can write the processor via FIFO B.

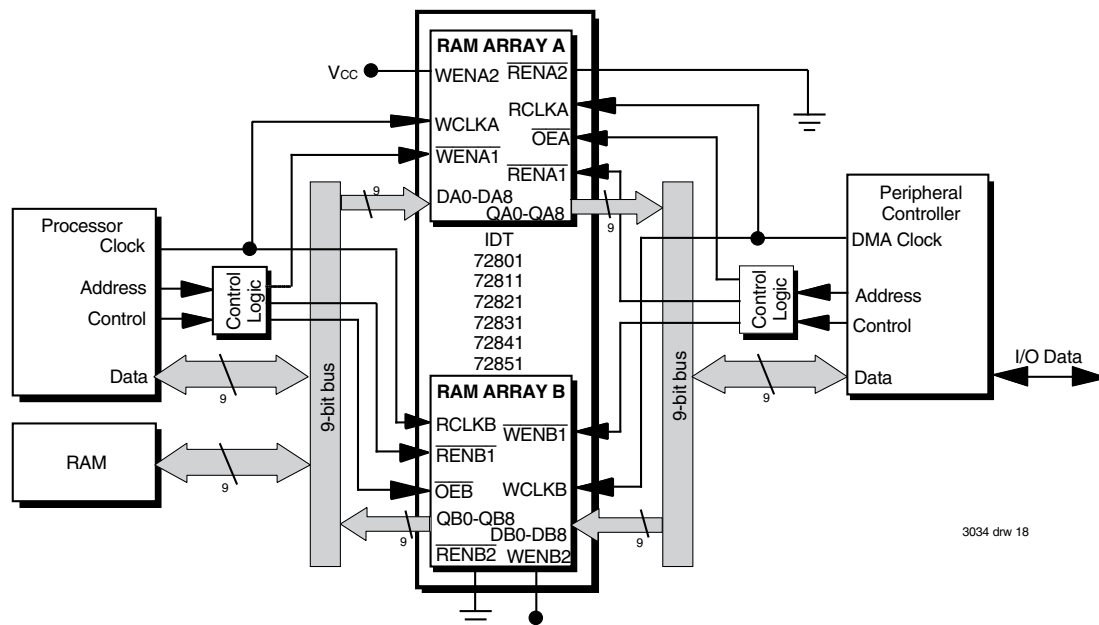

Figure 17. Block Diagram of Bidirectional Configuration

DEPTH EXPANSION — IDT72801/72811/72821/72831/72841/72851 can be adapted to applications that require greater than 256/512/1,024/2,048/4,096/8,192 words. The existence of double enable pins on the read and write ports allow depth expansion. The Write Enable 2/Load (WENA2, WENB2) pins are used as a second write enables in a depth expansion configuration, thus the Programmable flags are set to the default values. Depth expansion is possible by using one enable input for system control while the other enable input is controlled by expansion logic to direct the flow of data. A typical application would have the expansion logic alternate data

access from one device to the next in a sequential manner. These FIFOs operate in the Depth Expansion configuration when the following conditions are met:

1. WENA2/LDA and WENB2/LDB pins are held HIGH during Reset so that these pins operate as second Write Enables.
2. External logic is used to control the flow of data.

Please see the Application Note "DEPTH EXPANSION OF IDT'S SYNCHRONOUS FIFOs USING THE RING COUNTER APPROACH" for details of this configuration.

ORDERING INFORMATION

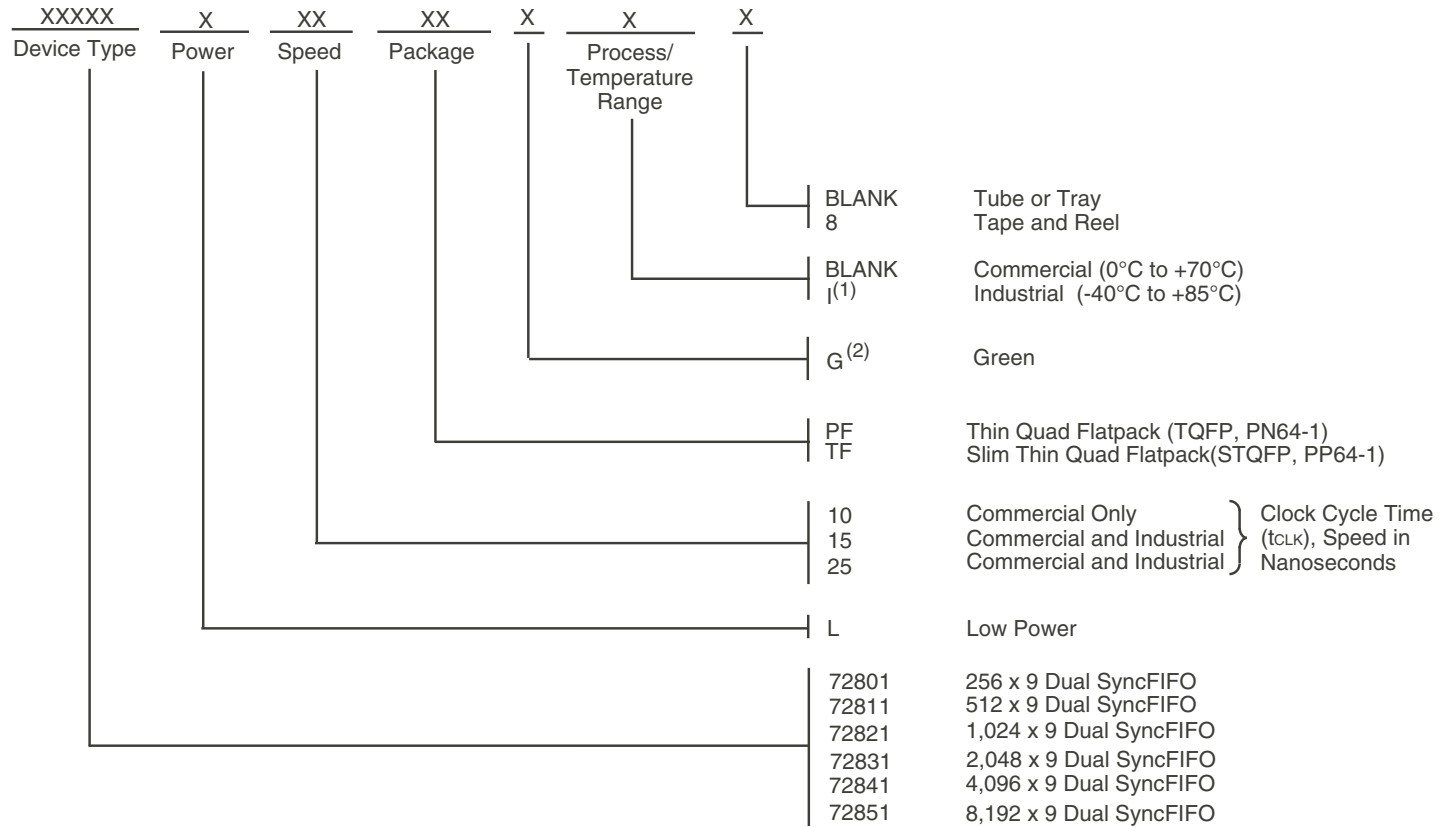

3034 drw 19

NOTES:

1. Industrial temperature range product for 15ns and 25ns speed grade are available as a standard device.
2. Green parts are available. For specific speeds and packages contact your sales office.

LEAD FINISH (SnPb) parts are in EOL process. Product Discontinuation Notice - PDN# SP-17-02

DATASHEET DOCUMENT HISTORY

04/24/2001	pgs. 4, 5 and 16.
02/10/2006	pgs. 1 and 16.
01/13/2009	pg. 16.
03/20/2013	pg. 1, 3, 7 and 16.
02/01/2018	Product Discontinuation Notice - PDN# SP-17-02 Last time buy expires June 15, 2018.

IMPORTANT NOTICE AND DISCLAIMER

RENESAS ELECTRONICS CORPORATION AND ITS SUBSIDIARIES (“RENESAS”) PROVIDES TECHNICAL SPECIFICATIONS AND RELIABILITY DATA (INCLUDING DATASHEETS), DESIGN RESOURCES (INCLUDING REFERENCE DESIGNS), APPLICATION OR OTHER DESIGN ADVICE, WEB TOOLS, SAFETY INFORMATION, AND OTHER RESOURCES “AS IS” AND WITH ALL FAULTS, AND DISCLAIMS ALL WARRANTIES, EXPRESS OR IMPLIED, INCLUDING, WITHOUT LIMITATION, ANY IMPLIED WARRANTIES OF MERCHANTABILITY, FITNESS FOR A PARTICULAR PURPOSE, OR NON-INFRINGEMENT OF THIRD PARTY INTELLECTUAL PROPERTY RIGHTS.

These resources are intended for developers skilled in the art designing with Renesas products. You are solely responsible for (1) selecting the appropriate products for your application, (2) designing, validating, and testing your application, and (3) ensuring your application meets applicable standards, and any other safety, security, or other requirements. These resources are subject to change without notice. Renesas grants you permission to use these resources only for development of an application that uses Renesas products. Other reproduction or use of these resources is strictly prohibited. No license is granted to any other Renesas intellectual property or to any third party intellectual property. Renesas disclaims responsibility for, and you will fully indemnify Renesas and its representatives against, any claims, damages, costs, losses, or liabilities arising out of your use of these resources. Renesas' products are provided only subject to Renesas' Terms and Conditions of Sale or other applicable terms agreed to in writing. No use of any Renesas resources expands or otherwise alters any applicable warranties or warranty disclaimers for these products.

(Disclaimer Rev.1.0 Mar 2020)

Corporate Headquarters

TOYOSU FORESIA, 3-2-24 Toyosu,
Koto-ku, Tokyo 135-0061, Japan
www.renesas.com

Contact Information

For further information on a product, technology, the most up-to-date version of a document, or your nearest sales office, please visit:
www.renesas.com/contact/

Trademarks

Renesas and the Renesas logo are trademarks of Renesas Electronics Corporation. All trademarks and registered trademarks are the property of their respective owners.