

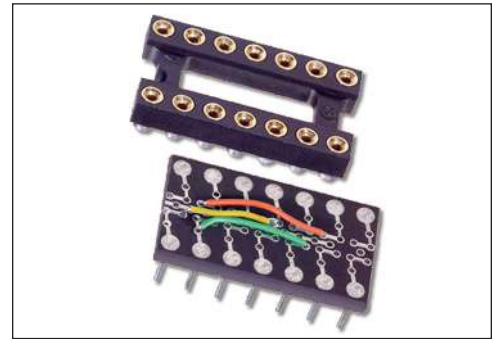

Program Your Own Correct-A-Chip™

GENERAL SPECIFICATIONS

- FEMALE SOCKET MATERIAL: black UL 94V-0 glass-filled 4/6 Nylon 170°C continuous use temp.
- PCB: FR-4, 0.062 [1.56] or 0.094 [2.39] thick
- MALE PINS: Brass 360 1/2-hard per UNS C36000, ASTM-B16-00
- MALE PIN PLATING: 200µ [5.08µ] Sn/Pb 93/7 ASTM B579-73 over 100µ [2.54µ] Ni per SAE AMS-QQ-N-290
- FEMALE PIN BODY: Brass 360 1/2-hard per UNS C 36000, ASTM B16/B16M
- 4-FINGER COLLET CONTACT: BeCu per UNS C17200, ASTM B194-08
- CONTACT PLATING: 10µ [0.25µ] Au per MIL-G-45204 over 50µ [1.27µ] Ni per SAE AMS-QQN-290
- MINIMUM CONTACT CURRENT RATING: 1 amp @ 5VDC
- OPERATING TEMPERATURE: 221°F [105°C]
- INSERTION FORCE: 180g/pin, based on a 0.018 [0.46] dia. test lead
- WITHDRAWAL FORCE: 90g/pin, based on a 0.018 [0.46] dia. test lead
- NORMAL FORCE: 140g/pin, based on a 0.018 [0.46] dia. test lead
- SOCKET ACCEPTS LEADS: 0.015-0.025 [0.38-0.64] in dia., 0.100-0.125 [2.54-3.18] long 0.015 dia. holes in PCB for #30 AWG Kynar® wire or equivalent



CUSTOMIZATION: In addition to the standard products shown on this page, Aries specializes in custom design and production. Special materials, platings, sizes, and configurations can be furnished, depending on the quantity. **NOTE:** Aries reserves the right to change product general specifications without notice.

MOUNTING CONSIDERATIONS

- Standard thru hole

ORDERING INFORMATION

1109800-XX

Series

No. of Pins

8, 14, 16, 18, 20, 22, 24, 28

ALL DIMENSIONS: INCHES [MILLIMETERS]

ALL TOLERANCES: ±0.005 [0.13] UNLESS OTHERWISE SPECIFIED

CONSULT FACTORY FOR OTHER SIZES AND CONFIGURATIONS

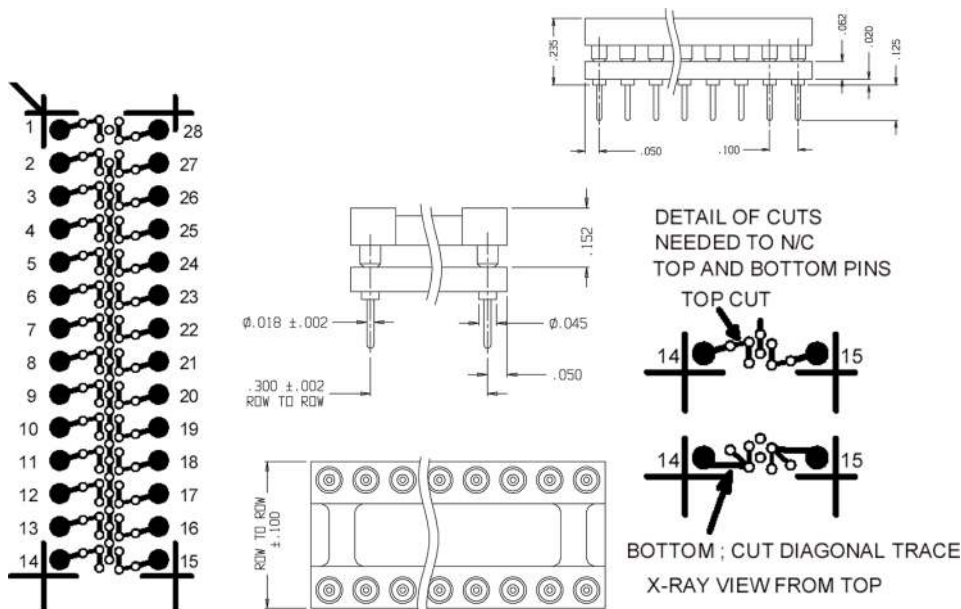

Bristol, PA 19007-6810 USA
 TEL (215) 781-9956 • FAX (215) 781-9845
 WWW.ARIESELEC.COM • INFO@ARIESELEC.COM