

Panasonic
ideas for life

**HIGH CAPACITY,
LONG LIFE SUBMINIATURE
SWITCH**

**AVM3□□□P (PS)
SWITCHES**

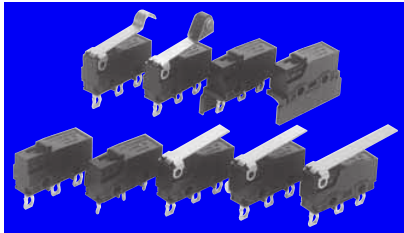

FEATURES

- 10.1 Amp. high contact capacity is available
- Long life
- Precise operating position ($\pm 0.25\text{mm}$: Pin plunger type)
- Flux-resistant construction with integrally molded terminals
- In-line terminals make soldering works easy
- UL/CSA/SEMKO approved

TYPICAL APPLICATIONS

- Heaters
- Electric rice cookers
- Copiers
- Printers
- Facsimiles
- Vending machines
- Measuring equipment
- Audio equipment

ORDERING INFORMATION

Ex. AVM3 1 0 5 P 3

Type of switch	Terminals	Actuators	Operating force by pin plunger, max.	Capacity	Agency standard
PS switch	1: Self-standing solder terminal with guard 2: Self-standing solder terminal without guard 3: Self-standing solder terminal with opposite side guard 4: Self-standing PC terminal	0: Pin plunger 1: Short hinge lever 2: Hinge lever 3: Long hinge lever 4: Simulated roller lever 5: Roller lever	5: 1.47 N	P: High capacity (10.1 A)	3: UL/CSA/SEMKO

CONSTRUCTION

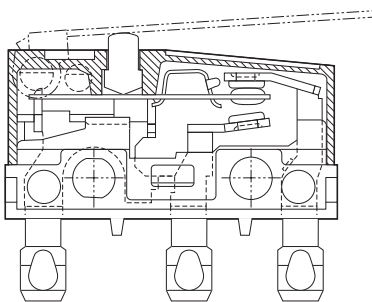

CONTACT ARRANGEMENT: SPDT

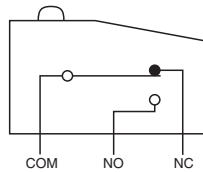

DATA

Electrical life curve

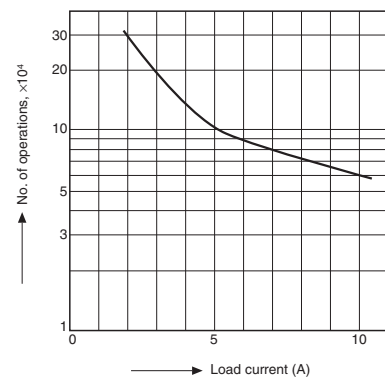

PRODUCT TYPES

Contact	Actuator	Part No.			
		Self-standing solder terminal			Self-standing PC terminal
		Without guard	With guard	With opposite side guard	
Gold-clad	Pin plunger	AVM3205P3	AVM3105P3	AVM3305P3	AVM3405P3
	Short hinge lever	AVM3215P3	AVM3115P3	AVM3315P3	AVM3415P3
	Hinge lever	AVM3225P3	AVM3125P3	AVM3325P3	AVM3425P3
	Long hinge lever	AVM3235P3	AVM3135P3	AVM3335P3	AVM3435P3
	Simulated roller lever	AVM3245P3	AVM3145P3	AVM3345P3	AVM3445P3
	Roller lever	AVM3255P3	AVM3155P3	AVM3355P3	AVM3455P3

SPECIFICATIONS

1. Contact rating

Resistive load ($\cos \phi \approx 1$)	10.1A, 250V AC
--	----------------

2. Characteristics

Expected life	Electrical	Min. 5×10^4 (at 20 cpm) (O.T. max.)
	Mechanical	Min. 3×10^7 (O.T.: Specified value), at 60 cpm
Dielectric strength	Between terminals	1,000 Vrms for 1 min. (at 10 mA)
	Between terminals and other exposed metal parts	2,000 Vrms for 1 min. (at 10 mA)
	Between terminals and ground	2,000 Vrms for 1 min. (at 10 mA)
Insulation resistance		Min. 100M Ω (at 500V DC)
Contact resistance (initial)		Max. 50m Ω (By voltage drop, 1A 6 to 8V DC)
Allowable operating speed (at no load)		0.1 to 1,000 mm/sec.
Max. operating cycle rate (at no load)		300 cpm
Ambient temperature		-25 to +85°C (Not freezing below 0°C)
Unit weight		Approx. 2g
Contact material		AgNi alloy

3. Operating characteristics

Actuator	Operating force, Max.	Release force, Min.	Pretravel, Max. mm	Movement differential, Max. mm	Overtravel, Min. mm	Operating position mm
Pin plunger	1.47 N	0.20 N	0.6 mm	0.1 mm	0.4 mm	8.4 \pm 0.25 mm
Short hinge lever	0.59 N	0.039 N	2.5 mm	0.5 mm	0.8 mm	8.8 \pm 0.8 mm
Hinge lever	0.54 N	0.034 N	2.8 mm	0.8 mm	1.2 mm	8.8 \pm 0.8 mm
Long hinge lever	0.44 N	0.029 N	3.5 mm	1.0 mm	1.6 mm	8.8 \pm 1.2 mm
Simulated roller lever	0.54 N	0.034 N	2.8 mm	0.8 mm	1.2 mm	11.65 \pm 0.8 mm
Roller lever	0.59 N	0.039 N	2.5 mm	0.5 mm	0.8 mm	14.5 \pm 0.8 mm

DIMENSIONS

mm General tolerance: ± 0.25

1. Self-standing PC terminal (Without guard)

Pin plunger

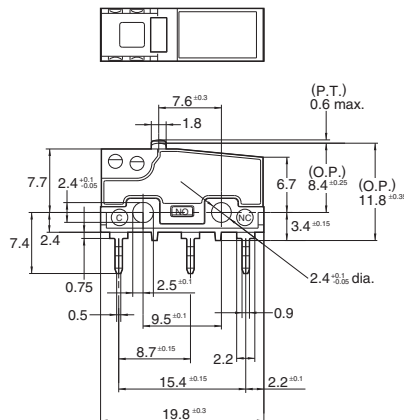

PC board pattern

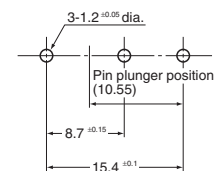

Pretravel, Max. mm	0.6
Movement differential, Max. mm	0.1
Overtravel, Min mm	0.4
Operating position	Distance from mounting hole, mm
	8.4 \pm 0.25

AVM3□□□P

Short hinge lever

mm General tolerance: ± 0.25

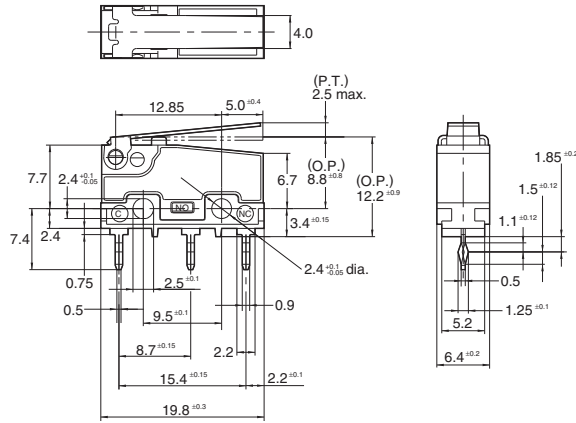

Pretravel, Max. mm		2.5
Movement differential, Max. mm		0.5
Overtravel, Min mm		0.8
Operating position	Distance from mounting hole, mm	8.8 \pm 0.8

Hinge lever

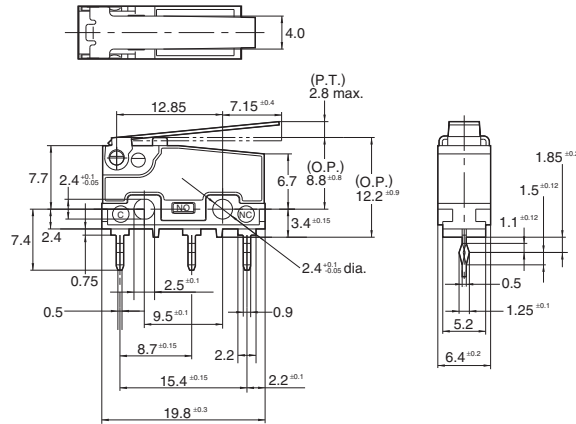
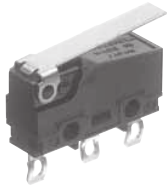

Pretravel, Max. mm		2.8
Movement differential, Max. mm		0.8
Overtravel, Min mm		1.2
Operating position	Distance from mounting hole, mm	8.8 \pm 0.8

Long hinge lever

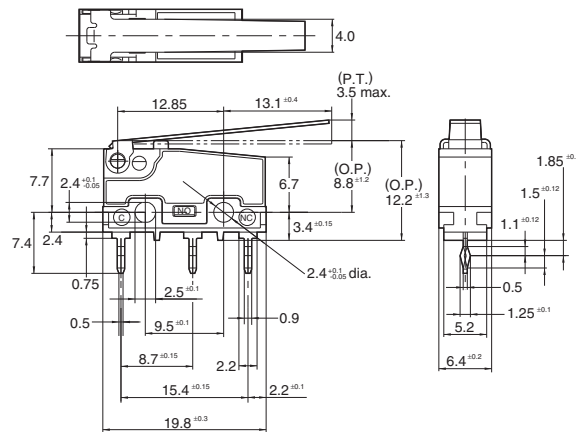
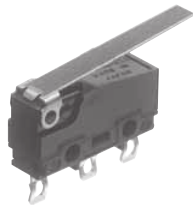

Pretravel, Max. mm		3.5
Movement differential, Max. mm		1.0
Overtravel, Min mm		1.6
Operating position	Distance from mounting hole, mm	8.8 \pm 1.2

Simulated roller lever

mm General tolerance: ±0.25

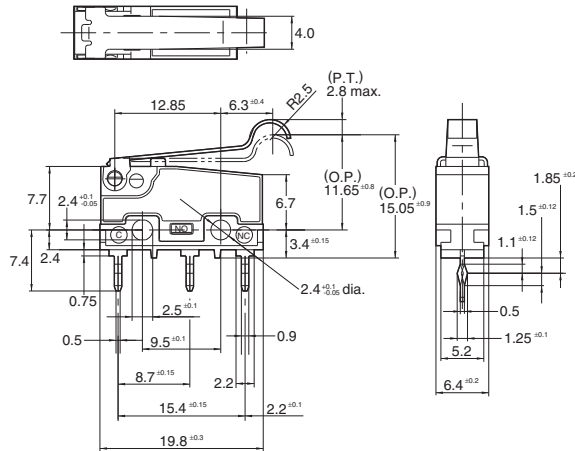

Pretravel, Max. mm	2.8
Movement differential, Max. mm	0.8
Overtravel, Min mm	1.2
Operating position	Distance from mounting hole, mm
	11.65±0.8

Roller lever

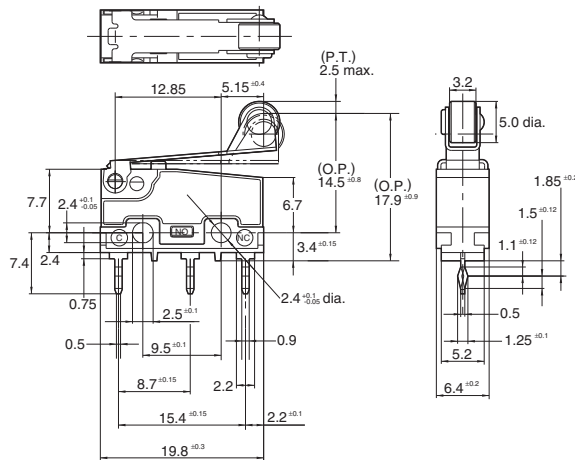

Pretravel, Max. mm	2.5
Movement differential, Max. mm	0.5
Overtravel, Min mm	0.8
Operating position	Distance from mounting hole, mm
	14.5±0.8

2. Self-standing solder terminal
Pin plunger

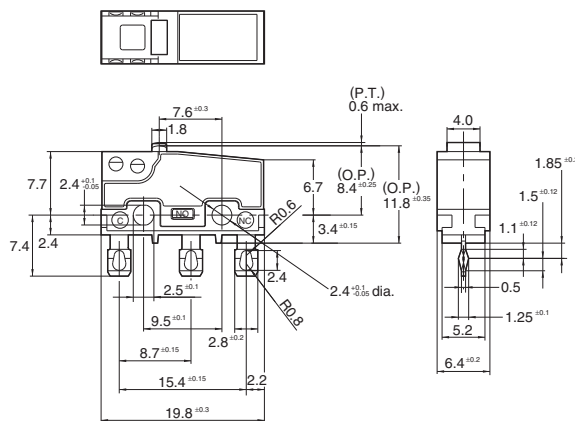

With guard

With opposite side guard

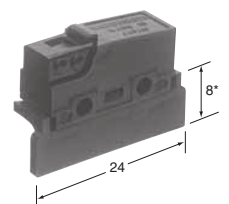
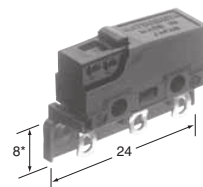

* The height from the center of mounting hole to the edge of guard.

NOTES

1. Fastening of the switch body

- 1) Use flat filister head M2.3 screws to mount switches with less than a 0.29 N·m torque. Use of screws washers or adhesive lock is recommended to prevent loosening of the screws.
- 2) Check insulation distance between ground and each terminal.
- 3) When the operation object is in the free position, force should not be applied directly to the actuator or pin plunger from vertical direction to the switch.
- 4) In setting the movement after operation, the over-travel should be set more than 70% as a standard. Setting the movement at less than 70% of O.T. may cause troubles such as miscontact and welding due to small contact force of the switch.
- 5) For a lever type, the force from the reverse and side to the operation direction should not be applied.

2. Soldering operations

- For manual soldering:
Soldering should be accomplished in less than 3 seconds, with a 60 watt iron. Care should be taken not to apply force to the terminal during soldering.
- For automatic soldering:
Soldering should be done less than 6 seconds in 260°C soldering bath or less than 3 seconds in 350°C soldering bath. Terminal portions should not be moved within 1 minute after soldering. Also no tensile strength of lead wires should be applied to the terminals.
- ### 3. Selection of the switch
- When specifying the switch, allow $\pm 20\%$ to the listed operating characteristics.
- ### 4. Environment
- Avoid using the switches in the following conditions;
- In corrosive gases, such as silicon gas
 - In a dusty environment

5. Cautions regarding use

When switching low-level circuits (6V DC 5mA, 12V DC 2mA, 24V DC 1mA), FS/FS-T Au clad contact type switches are recommended. When used to switch inductive loads (relays, solenoids, buzzers, etc.), it is recommended that a proper spark quench circuit is inserted in the switch to prevent contact faults caused by electric arcs. Care should be taken that occurrence in AC load possibly shorten the expected life.

6. Quality check under actual loading conditions

To assure reliability, check the switch under actual loading conditions. Avoid any situation that may adversely affect switching performance.