

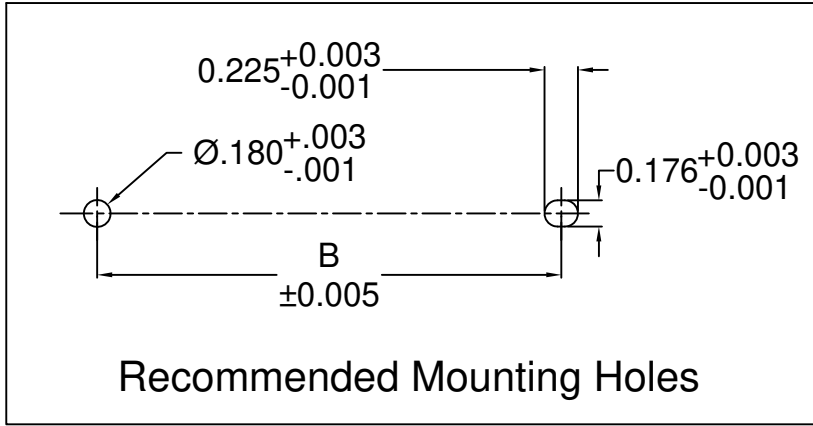

REV.	DESCRIPTION	DATE	APPROVED
H	Engineering Release.	11/01/13	T. Y.
J	Updated Material Note.	03/08/16	J. C.

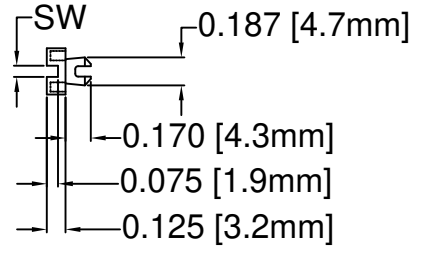
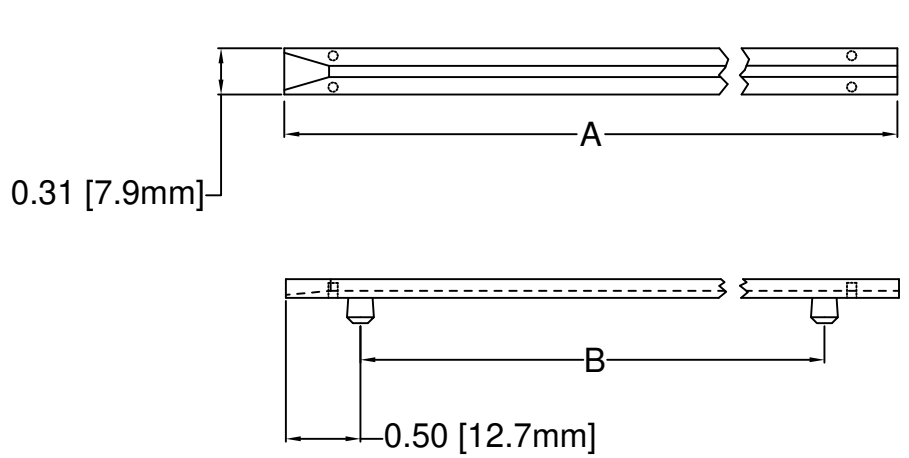

PART NO.		A ±.032 (.8)	B ±.016 (.4)
SSD-250	SSD-250-102	2.5 (63.5)	1.5 (38.1)
SSD-300	SSD-300-102	3.0 (76.2)	2.0 (50.8)
SSD-350	SSD-350-102	3.5 (88.9)	2.5 (63.5)
SSD-400	SSD-400-102	4.0 (101.6)	3.0 (76.2)
SSD-450 3X	-	4.5 (114.3)	3.0 (76.2)
SSD-450	SSD-450-102	4.5 (114.3)	3.5 (88.9)
SSD-500	SSD-500-102	5.0 (127.0)	4.0 (101.6)
SSD-550	SSD-550-102	5.5 (139.7)	4.5 (114.3)
SSD-600	SSD-600-102	6.0 (152.4)	5.0 (127.0)
SSD-650	SSD-650-102	6.5 (165.1)	5.5 (139.7)
SSD-700	SSD-700-102	7.0 (177.8)	6.0 (152.4)
SSD-750	SSD-750-102	7.5 (190.5)	6.5 (165.1)
SSD-800	SSD-800-102	8.0 (203.2)	7.0 (177.8)
SW=0.075 (1.9)	SW=0.102 (2.6)		

3. ALL DIMENSIONS IN INCHES, UNLESS OTHERWISE SPECIFIED.
2. MATERIAL: NYLON 6/6, 94V-2, NATURAL.
1. GENERAL SPECIFICATIONS: BIVAR MOLDED COMPONENT SPECIFICATION BV00-E101.

STANDARD TOLERANCE (UNLESS OTHERWISE SPECIFIED)		 BIVAR [®] 4 THOMAS, IRVINE, CA. 92618 TEL: (949) 951-8808 FAX: (949) 951-3974	
DECIMALS	ANGULAR		
.X ±.1	X° ± 1°	 TITLE: INTERCHANGEABLE SNAP-IN CARD GUIDE	
.XX ±.01			
.XXX ±.005		PART NO: SSD-XXX-XXX	
DESIGNED: David Green	DATE: 11/26/02	REVISION: J	
CHECKED: M. Chen	DATE: 11/26/02	CAGE CODE : 32559 SHEET # 1 OF 1	
CAD GENERATED DOCUMENT. DO NOT MEASURE DRAWING.			