

PCB LAYOUT: COMPONENT SIDE
RECOMMENDED PCB THICKNESS: .062/1.57

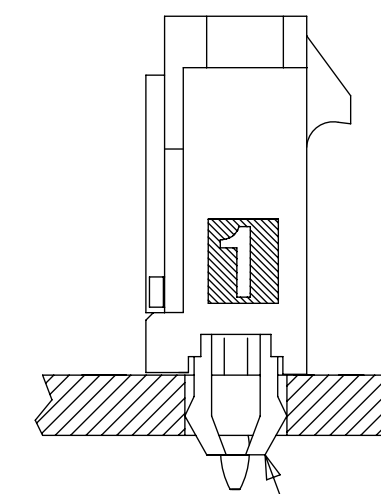
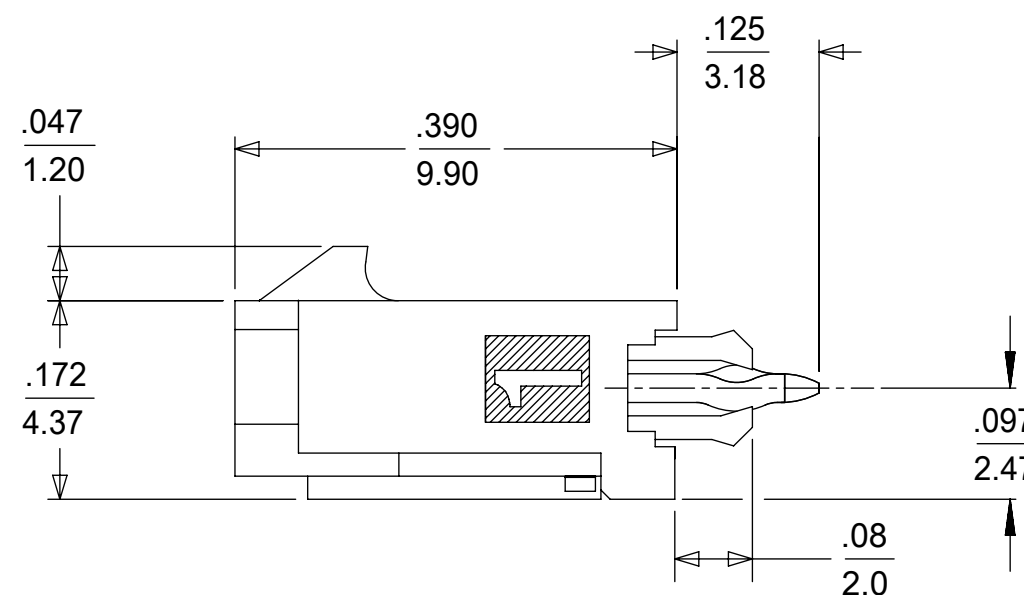
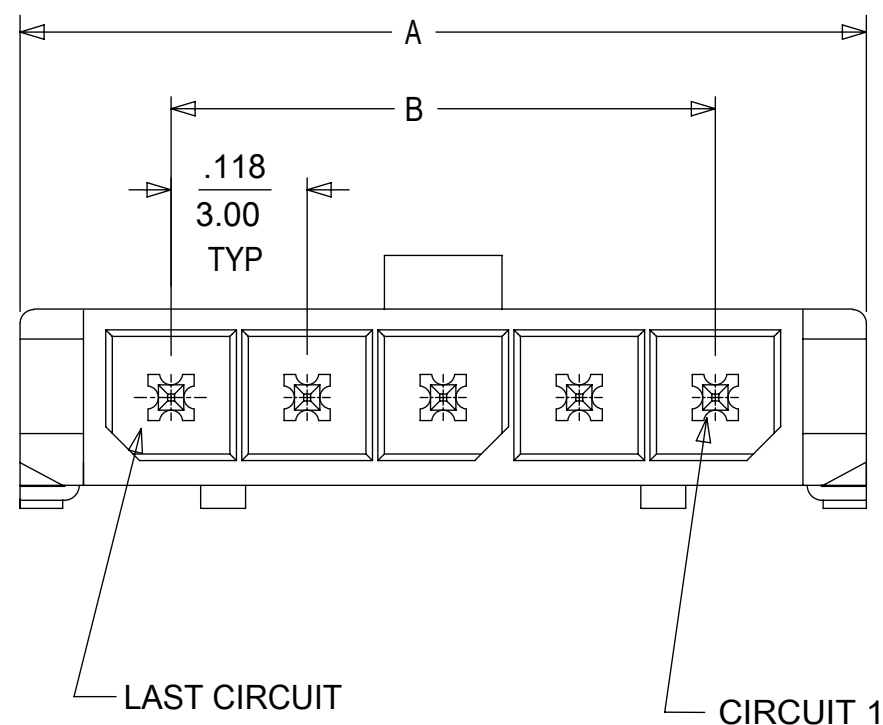

CKTS	DIM A	DIM B	DIM C
2	.380 9.65	.118 3.00	.287 7.30
3	.498 12.65	.236 6.00	.405 10.30
4	.616 15.65	.354 9.00	.524 13.30
5	.734 18.64	.472 12.00	.642 16.30
6	.852 21.64	.591 15.00	.760 19.30
7	.970 24.64	.709 18.00	.878 22.30
8	1.088 27.64	.827 21.00	.996 25.30
9	1.206 30.63	.945 24.00	1.114 28.30
10	1.325 33.66	1.063 27.00	1.232 31.30
11	1.443 36.65	1.181 30.00	1.350 34.30
12	1.561 39.65	1.299 33.00	1.469 37.30

CKTS	FINISH A		FINISH B		FINISH C		FINISH D	
	MATERIAL NO:	VOID CKT	MATERIAL NO:	VOID CKT	MATERIAL NO:	VOID CKT	MATERIAL NO:	VOID CKT
02	43650-0218		43650-0219		43650-0220		43650-0263	
03	43650-0318		43650-0319		43650-0320		43650-0363	
04	43650-0418		43650-0419		43650-0420		43650-0463	
05	43650-0518		43650-0519		43650-0520		43650-0563	
06	43650-0618		43650-0619		43650-0620		43650-0663	
07	43650-0718		43650-0719		43650-0720		43650-0763	
08	43650-0818		43650-0819		43650-0820		43650-0863	
09	43650-0918		43650-0919		43650-0920		43650-0963	
10	43650-1018		43650-1019		43650-1020		43650-1063	
11	43650-1118		43650-1119		43650-1120		43650-1163	
12	43650-1218		43650-1219		43650-1220		43650-1263	
03	43650-0331	02	43650-0332	02				
04	43650-1431	2,3	43650-0436	2,3				
04	43650-2431	4						
05	43650-1531	2,3,4						
06	43650-0631	6	43650-0636	2,3,4,5				

NOTES:

- HOUSING MATERIAL: LIQUID CRYSTAL POLYMER, GLASS FILLED, UL94V-0, COLOR: BLACK
TERMINAL MATERIAL: BRASS ALLOY
- FINISH:
A = .000060/(0.00152) MIN. REFLOWED MATTE TIN OVER
.000050/(0.00127) MIN. NICKEL PLATE
(FINISH IS BRIGHT IN APPEARANCE, THICKNESS AS APPLIED PRIOR TO REFLOW)
B = .00015/(0.00038) MIN. SELECT GOLD IN CONTACT AREA
.000100/(0.00254) MIN. SELECT MATTE TIN ON SOLDER TAILS BOTH OVER .000050/(0.00127) NICKEL OVERALL
C = .000030/(0.00076) MIN. SELECT GOLD IN CONTACT AREA
.000100/(0.00254) MIN. SELECT MATTE TIN ON SOLDER TAILS BOTH OVER .000050/(0.00127) NICKEL OVERALL
D = .000100/(0.00254) MIN. MATTE TIN OVER
.000050/(0.00127) MIN. NICKEL OVERALL
- PRODUCT SPECIFICATION: PS-43650
- TRAY PACKAGED : SEE MOLEX DRAWING PK-70873-0811
- MATES WITH MICRO FIT (3.0) RECEPTACLE SERIES 43645
- PARTS CONFORM TO CLASS 'B' REQUIREMENTS OF COSMETIC SPECIFICATION PS-45499-002.
- TEXT ON PART IS FOR REFERENCE ONLY. TEXT AND TEXT LOCATION MAY VARY DEPENDING ON PART NUMBER AND/OR TOOL.

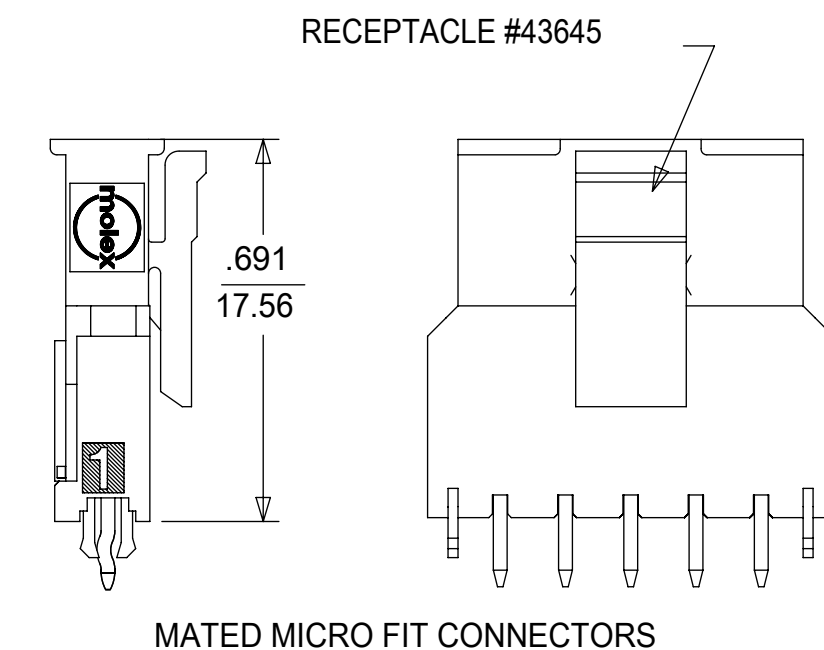

FUNCTIONAL SYMBOLS	THIS DRAWING CONTAINS INFORMATION THAT IS PROPRIETARY TO MOLEX ELECTRONIC TECHNOLOGIES, LLC AND SHOULD NOT BE USED WITHOUT WRITTEN PERMISSION		CURRENT REV DESC: ADD 43650-0332	
	DIMENSION UNITS	SCALE		
$F_A = 0$	INCH/MM	NTS		
$F_C = 0$	GENERAL TOLERANCES (UNLESS SPECIFIED)			
$F_P = 0$		MM	INCH	
DIVISIONAL SYMBOLS	4 PLACES	±	±	
	3 PLACES	±	± 0.01	
	2 PLACES	± 0.25	± 0.014	
	1 PLACE	± 0.36	±	
	0 PLACES	±	±	
	ANGULAR TOL	± 0.5 °		
DRAFT WHERE APPLICABLE MUST REMAIN WITHIN DIMENSIONS		THIRD ANGLE PROJECTION	DRAWING	SERIES
			C-SIZE	43650
		EC NO: 677247	2021/09/10	
		DRWN: MKIPPER	2021/09/10	
		CHK'D: HENRYA1	2021/09/27	
		APPR: FSMITH		
		INITIAL REVISION:		
		DRWN: SAMIEC	2000/07/07	
		APPR: FSMITH	2016/08/23	
DOCUMENT NUMBER		DOC TYPE	DOC PART	REVISION
SD-43650-007		PSD	001	F5
MATERIAL NUMBER		CUSTOMER		SHEET NUMBER
SEE TABLE		GENERAL MARKET		1 OF 1