

Longwipe-SMP

Adaptor
Long Wipe SMP Jack –
Long Wipe SMP Jack

17K117-K02L5

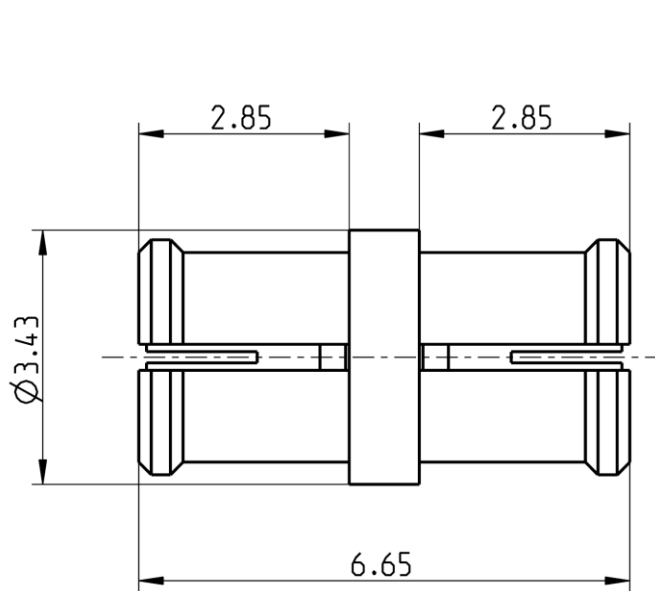

All dimensions are in mm; tolerances according to ISO 2768 m-H

Interface

According to Long-wipe SMP (Rosenberger 17S000-000)

Documents

N/A

Material and plating

Connector parts

Center contact
Outer contact
Dielectric

Material

CuBe
CuBe
PTFE

Plating

AuroDur®, gold plated
AuroDur®, gold plated

Dieses Dokument ist urheberrechtlich geschützt • This document is protected by copyright • Rosenberger Hochfrequenztechnik GmbH & Co. KG

RF_35/09.14/6.2

Longwipe-SMP

Adaptor
Long Wipe SMP Jack –
Long Wipe SMP Jack

17K117-K02L5

Electrical data

Impedance	50 Ω
Frequency	DC to 6 GHz
Return loss	≥ 26 dB, DC to 4 GHz
Insertion loss	≤ 0.05 x √f(GHz) dB
Insulation resistance	≥ 5 GΩ
Center contact resistance	≤ 6.0 mΩ
Outer contact resistance	≤ 2.0 mΩ
Test voltage	500 V rms
Working voltage	335 V rms
Contact Current	≤ 1.2A DC

Mechanical data

Mating cycles	
if mating part is Smooth Bore	≥ 1000
if mating part is Limited Detent	≥ 500
if mating part is Full Detent	≥ 100
Center contact captivation	≥ 5 N
Engagement force	
- Smooth Bore	≤ 9 N
- Limited Detent	≤ 45 N
- Full Detent	≤ 68 N
Disengagement force	
- Smooth Bore	≥ 2.2 N
- Limited Detent	≥ 9 N
- Full Detent	≥ 22 N

Environmental data

Temperature range	-65 °C to +155 °C
Thermal shock	MIL-STD-202, Method 107, Condition B
Vibration	MIL-STD-202, Method 204, Condition B
Shock	MIL-STD-202, Method 213, Condition A
Moisture resistance	MIL-STD-202, Method 106
RoHS	compliant

Tooling

N/A

Suitable cables

N/A

Weight

Weight 0.15 g/pce

While the information has been carefully compiled to the best of our knowledge, nothing is intended as representation or warranty on our part and no statement herein shall be construed as recommendation to infringe existing patents. In the effort to improve our products, we reserve the right to make changes judged to be necessary.

For the installation of the electrotechnical equipment, particular electrotechnical expertise is required.



Draft	Date	Approved	Date	Rev.	Engineering change number	Name	Date
Gramsamer Josef	09.09.09	Chr. Janßen	20.10.20	c00	20-1927	S. Huber-Siegl	20.10.20

Rosenberger Hochfrequenztechnik GmbH & Co. KG
P.O.Box 1260 D-84526 Tittmoning Germany
www.rosenberger.de

Tel. : +49 8684 18-0
Email : info@rosenberger.de

Page
2 / 2