

GENERAL PURPOSE TRANSISTOR

DESCRIPTION

The BC141-16 is a silicon Planar Epitaxial NPN transistor in Jedec TO-39 metal case. It is particularly designed for audio amplifiers and switching application up to 1A.

The complementary PNP type is the BC161-16.

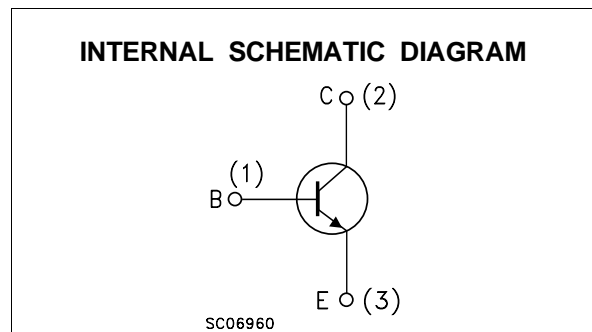
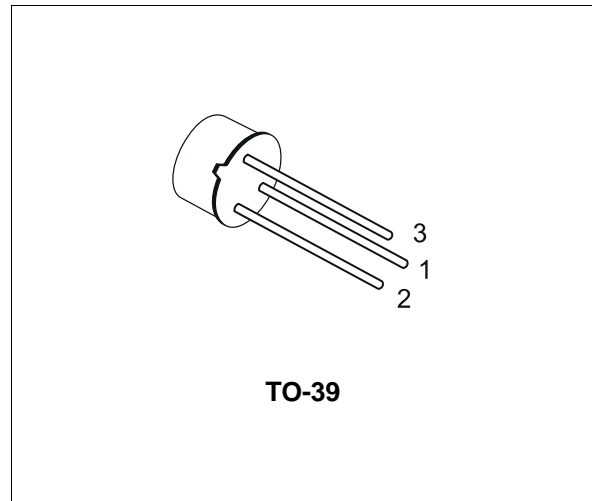

ABSOLUTE MAXIMUM RATINGS

Symbol	Parameter	Value	Unit
V_{CBO}	Collector-Base Voltage ($I_E = 0$)	100	V
V_{CEO}	Collector-Emitter Voltage ($I_B = 0$)	60	V
V_{EBO}	Emitter-Base Voltage ($I_C = 0$)	7	V
I_C	Collector Current	1	A
I_B	Base Current	0.1	A
P_{tot}	Total Dissipation at $T_{amb} \leq 25\text{ }^\circ\text{C}$ at $T_C \leq 25\text{ }^\circ\text{C}$	0.65	W
		3.7	W
T_{stg}	Storage Temperature	-55 to 175	$^\circ\text{C}$
T_j	Max. Operating Junction Temperature	175	$^\circ\text{C}$

THERMAL DATA

R _{thj-case}	Thermal Resistance Junction-Case	35	°C/W
R _{thj-amb}	Max Thermal Resistance Junction-Ambient	200	°C/W
	Max		

ELECTRICAL CHARACTERISTICS (T_{case} = 25 °C unless otherwise specified)

Symbol	Parameter	Test Conditions	Min.	Typ.	Max.	Unit
I _{CES}	Collector Cut-off Current (V _{BE} = 0)	V _{CE} = 60 V V _{CE} = 60 V T _C = 150 °C			100 100	nA μA
V _{(BR)CBO} *	Collector-Base Breakdown Voltage (I _E = 0)	I _C = 100 μA	100			V
V _{(BR)CEO} *	Collector-Emitter Breakdown Voltage (I _B = 0)	I _C = 30 mA	60			V
V _{(BR)EBO} *	Emitter-Base Breakdown Voltage (I _C = 0)	I _E = 100 μA	7			V
V _{CE(sat)} *	Collector-Emitter Saturation Voltage	I _C = 100 mA I _B = 10 mA I _C = 500 mA I _B = 50 mA I _C = 1 A I _B = 100 mA		0.1 0.35 0.6	1	V V V
V _{BE(on)} *	Base-Emitter On Voltage	I _C = 1 A V _{CE} = 1 V		1.25	1.8	V
h _{FE} *	DC Current Gain	I _C = 100 μA V _{CE} = 1 V I _C = 100 mA V _{CE} = 1 V I _C = 1 A V _{CE} = 1 V	100	90 160 30	250	
f _T	Transition Frequency	I _C = 50 mA V _{CE} = 10 V	50			MHz
C _{CBO}	Collector-Base Capacitance	I _E = 0 V _{CB} = 5 V f = 1MHz		12	25	pF
t _{on}	Turn-on Time	I _C = 100 mA I _{B1} = 5 mA			250	ns
t _{off}	Turn-off Time	I _C = 100 mA I _{B1} = I _{B2} = 5 mA			850	ns

* Pulsed: Pulse duration = 300 μs, duty cycle ≤ 1 %

Collector-emitter Saturation Voltage.

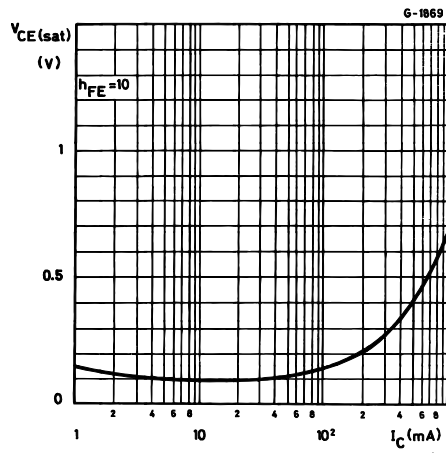

Base-emitter Voltage.

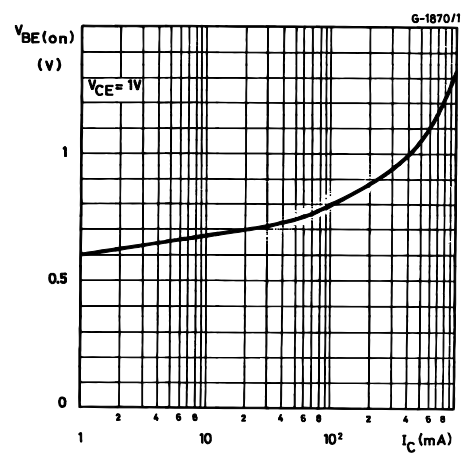

DC Current Gain.

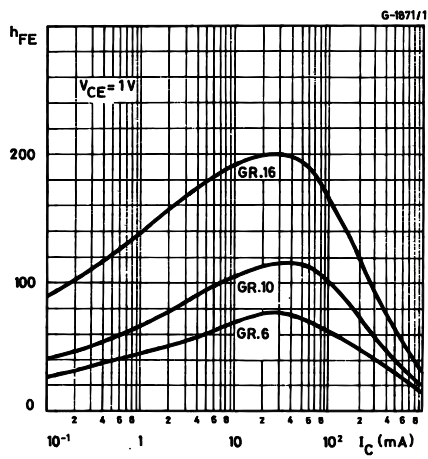

Transition Frequency.

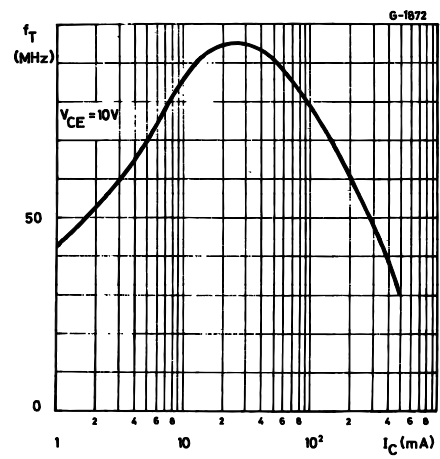

TO-39 MECHANICAL DATA

DIM.	mm			inch		
	MIN.	TYP.	MAX.	MIN.	TYP.	MAX.
A	12.7			0.500		
B			0.49			0.019
D			6.6			0.260
E			8.5			0.334
F			9.4			0.370
G	5.08			0.200		
H			1.2			0.047
I			0.9			0.035
L	45° (typ.)					

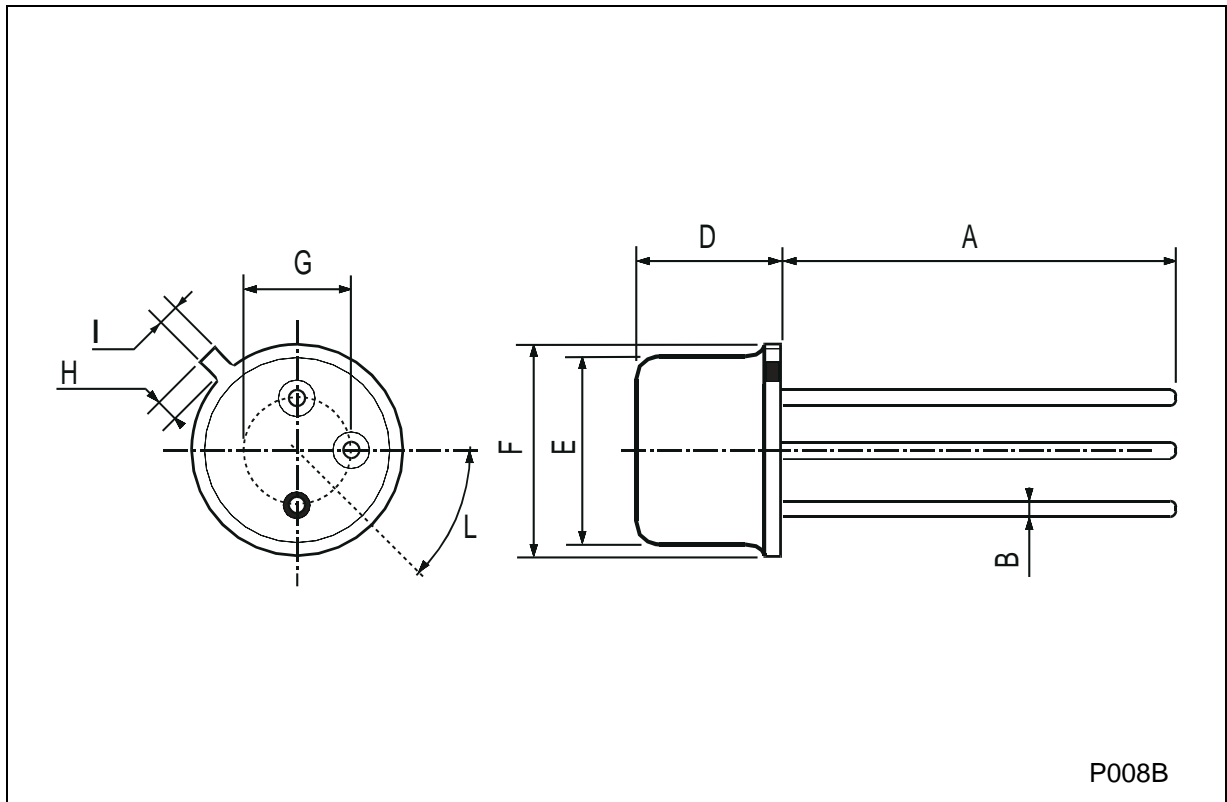

P008B

Information furnished is believed to be accurate and reliable. However, STMicroelectronics assumes no responsibility for the consequences of use of such information nor for any infringement of patents or other rights of third parties which may result from its use. No license is granted by implication or otherwise under any patent or patent rights of STMicroelectronics. Specification mentioned in this publication are subject to change without notice. This publication supersedes and replaces all information previously supplied. STMicroelectronics products are not authorized for use as critical components in life support devices or systems without express written approval of STMicroelectronics.

The ST logo is a trademark of STMicroelectronics

© 2002 STMicroelectronics – Printed in Italy – All Rights Reserved

STMicroelectronics GROUP OF COMPANIES

Australia - Brazil - Canada - China - Finland - France - Germany - Hong Kong - India - Israel - Italy - Japan - Malaysia - Malta - Morocco - Singapore - Spain - Sweden - Switzerland - United Kingdom - United States.

<http://www.st.com>

