

# 4-Channel Charge Pump White LED Driver with Low Dropout Current Source

## General Description

The RT9368 is a high efficiency and cost effective charge pump white LED driver. It supports up to 4 white LEDs with regulated constant current for uniform intensity. The RT9368 maintains the highest efficiency by utilizing a x1/x1.5/x2 charge pump and low dropout current regulators.

User can easily configure each LED current from 1.25mA to 20mA by a PWM dimming control. The dimming of white LEDs current can be achieved by applying a PWM signal to the EN pin.

RT9368 is available in a WQFN 3x3-16L package.

## Ordering Information



Note :

Richtek products are :

- ▶ RoHS compliant and compatible with the current requirements of IPC/JEDEC J-STD-020.
- ▶ Suitable for use in SnPb or Pb-free soldering processes.

## Marking Information

For marking information, contact our sales representative directly or through a Richtek distributor located in your area.

## Features

- Very High Efficiency Over 80% of Battery Life
- Support up to 4 White LEDs
- Support up to 80mA Output Current
- 1% Typical LED Current Matching
- Soft Start Function
- Auto Charge Pump Mode Selection
- 250kHz Fixed Frequency Oscillator
- Output Over Voltage Protection
- PWM Dimming Control
- Low Input Noise and EMI
- RoHS Compliant and 100% Lead (Pb)-Free

## Applications

- Mobile Phone, DSC, MP3
- White LED Backlighting
- LCD Display Supply

## Pin Configurations

(TOP VIEW)

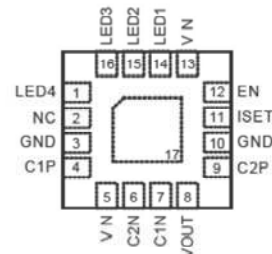

WQFN-16L 3x3

Typical Application Circuit

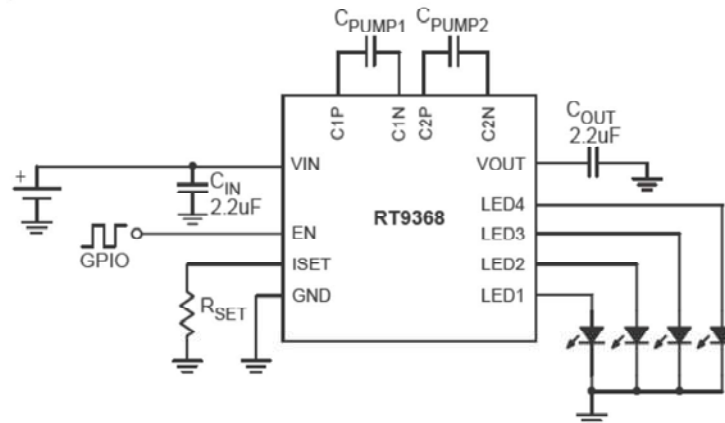

Figure 1. 4-WLEDs Application Circuit with PWM Dimming Function

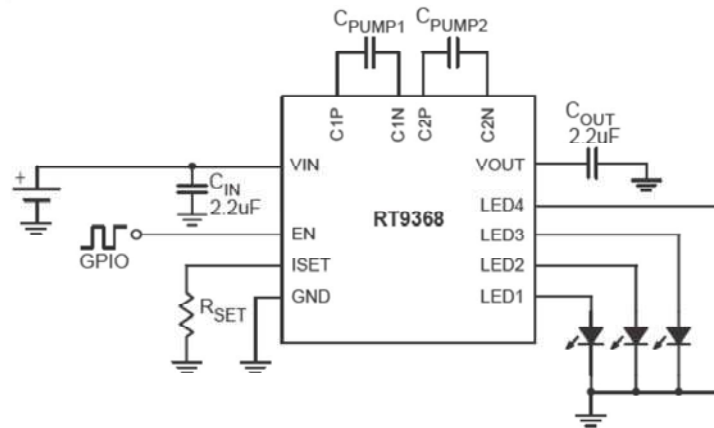

Figure 2. 3-WLEDs Application Circuit with PWM Dimming Function

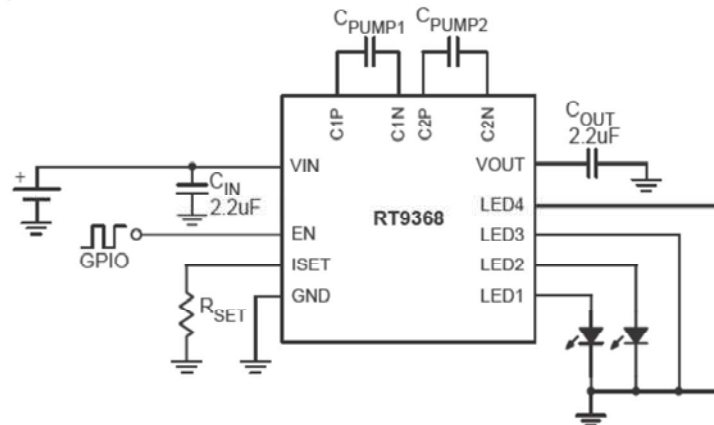

Figure 3. 2-WLEDs Application Circuit with PWM Dimming Function

C <sub>PUMP1</sub>	C <sub>PUMP2</sub>	Maximum output current (total)
0.22uF	0.22uF	60mA
0.47uF	0.47uF	100mA
1uF	1uF	160mA

**Functional Pin Description**

Pin No.	Pin Name	Pin Function
1	LED 4	Output Current for LED4. (If not in use, this pin must be connected to GND).
2, 17 (Exposed Pad)	NC	No Internal Connection.
3, 10	GND	Ground.
4	C1P	Positive Terminal of Bucket Capacitor 1.
5	VIN	Power Input Voltage.
6	C2N	Negative Terminal of Bucket Capacitor 2.
7	C1N	Negative Terminal of Bucket Capacitor 1.
8	VOUT	Output Voltage Source.
9	C2P	Positive Terminal of Bucket Capacitor 2.
11	ISET	LED current is set by the value of the resistor $R_{SET}$ connected from the ISET pin to ground. Do not short the ISET pin to GND directly.
12	EN	Chip Enable (Active High). Note that this pin is high impedance.
13	VIN	Power Input Voltage.
14	LED 1	Output Current for LED1. (If not in use, this pin must be connected to GND).
15	LED 2	Output Current for LED2. (If not in use, this pin must be connected to GND).
16	LED 3	Output Current for LED3. (If not in use, this pin must be connected to GND).

**Function Block Diagram**

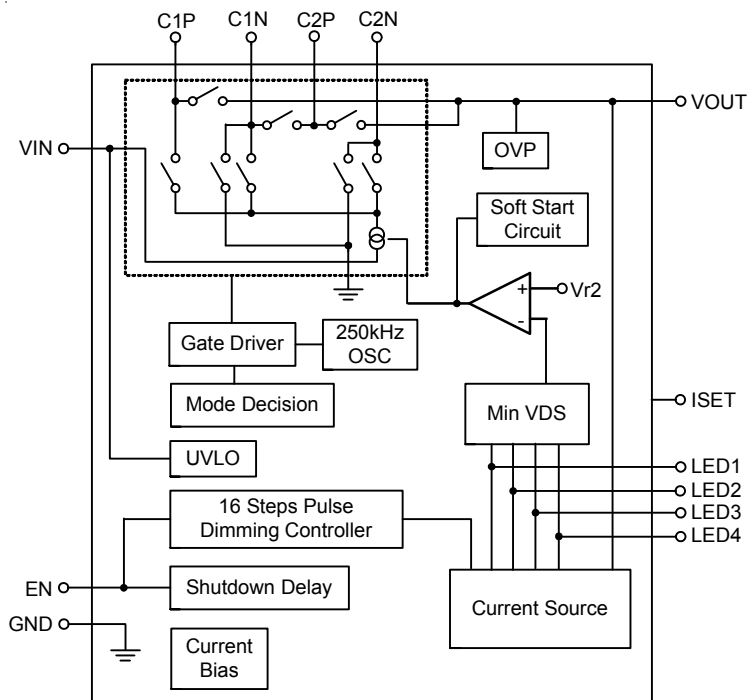

**Absolute Maximum Ratings** (Note 1)

- Supply Input Voltage ----- -0.3V to 6V
- Other I/O Pin Voltage ----- -0.3V to 6V
- Power Dissipation, PD @ T<sub>A</sub> = 25°C
  - WQFN-16L 3x3 ----- 1.47W
- Package Thermal Resistance (Note 2)
  - WQFN-16L 3x3, θ<sub>JA</sub> ----- 68°C/W
- Junction Temperature ----- 150°C
- Lead Temperature (Soldering, 10 sec.) ----- 260°C
- Storage Temperature Range ----- -40°C to 150°C
- ESD Susceptibility (Note 3)
  - HBM (Human Body Mode) ----- 2kV
  - MM (Machine Mode) ----- 200V

**Recommended Operating Conditions** (Note 4)

- Junction Temperature Range ----- -40°C to 125°C
- Ambient Temperature Range ----- -40°C to 85°C

**Electrical Characteristics**

(V<sub>IN</sub> = 3.6V, C<sub>IN</sub> = C<sub>OUT</sub> = C<sub>FLY</sub> = 1uF (ESR = 30mΩ), T<sub>A</sub> = 25°C, unless otherwise specification)

Parameter	Symbol	Test Condition	Min	Typ	Max	Units
<b>Input</b>						
Input Supply Voltage	V <sub>IN</sub>		2.8	--	5.0	V
Under-voltage Lockout Threshold		V <sub>IN</sub> Rising	1.6	2.1	2.5	V
Under-voltage Lockout Hysteresis			--	100	--	mV
Quiescent of x1 Mode	I <sub>Q_x1</sub>	x1 Mode, No Load, All LED pins connected to GND, V <sub>IN</sub> = 4V	0.5	1	2	mA
Quiescent of x2 Mode	I <sub>Q_x2</sub>	x2 Mode, No Load, All LED pins floating, V <sub>IN</sub> = 3.5V	1.5	2.5	5	mA
Shutdown Current	I <sub>SHDN</sub>	V <sub>EN</sub> = 0.4V, V <sub>IN</sub> = 2.8V to 5.5V	0	0.1	10	μA
x1 mode to x1.5 mode Transition Voltage (V <sub>IN</sub> falling)	V <sub>TS_x1.5</sub>	V <sub>F</sub> = 3.5V, I <sub>OUT</sub> = 80mA, I <sub>LEDx</sub> = 20mA	--	3.7	--	V
x1.5 mode to x2 mode Transition Voltage (V <sub>IN</sub> falling)	V <sub>TS_x2</sub>	V <sub>F</sub> = 3.5V, I <sub>OUT</sub> = 80mA, I <sub>LEDx</sub> = 20mA	--	3.0	--	V
Hysteresis of Mode Transition			--	100	--	mV
<b>Output</b>						
Current Range of I <sub>LEDx</sub>		2.8 < V <sub>IN</sub> < 5.5@V <sub>F</sub> = 3.2, I <sub>OUT</sub> = 60mA 3.0 < V <sub>IN</sub> < 5.5@V <sub>F</sub> = 3.4, I <sub>OUT</sub> = 80mA 3.3 < V <sub>IN</sub> < 5.5@V <sub>F</sub> = 3.8, I <sub>OUT</sub> = 80mA	1.25	--	20	mA
I <sub>LEDx</sub> Accuracy	I <sub>LED-ERR</sub>	100% Setting	-8	--	+8	%
Current Matching			-5	--	+5	%

*To be continued*

Parameter	Symbol	Test Condition	Min	Typ	Max	Units	
<b>Enable</b>							
EN Threshold Voltage	Logic-High	$V_{IH}$	1.5	--	--	V	
	Logic-Low	$V_{IL}$	--	--	0.4	V	
EN Current	Logic-High	$I_{IH}$	$V_{IH} = V_{IN}$	--	1	10	$\mu A$
	Logic-Low	$I_{IL}$	$V_{IL} = GND$	--	1	10	$\mu A$
EN Low Time for Shut Down	$T_{SHDN}$	PWM Dimming	--	8	--	ms	
<b>Frequency</b>							
PWM Dimming Frequency	$f_{PWM}$	Minimum Turn On > 30 $\mu s$	250	--	32k	Hz	
Oscillator Frequency	$f_{OSC}$		--	250	--	kHz	

**Note 1.** Stresses listed as the above "Absolute Maximum Ratings" may cause permanent damage to the device. These are for stress ratings. Functional operation of the device at these or any other conditions beyond those indicated in the operational sections of the specifications is not implied. Exposure to absolute maximum rating conditions for extended periods may remain possibility to affect device reliability.

**Note 2.**  $\theta_{JA}$  is measured in the natural convection at  $T_A = 25^\circ C$  on a low effective thermal conductivity test board of JEDEC 51-3 thermal measurement standard.

**Note 3.** Devices are ESD sensitive. Handling precaution is highly recommended.

**Note 4.** The device is not guaranteed to function outside its operating conditions.

Typical Operating Characteristics

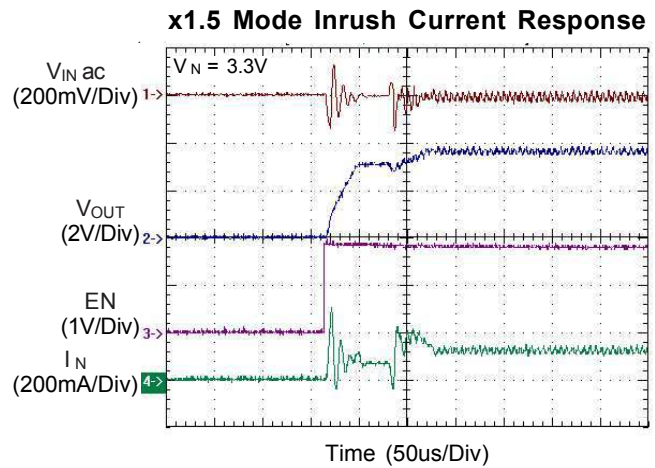
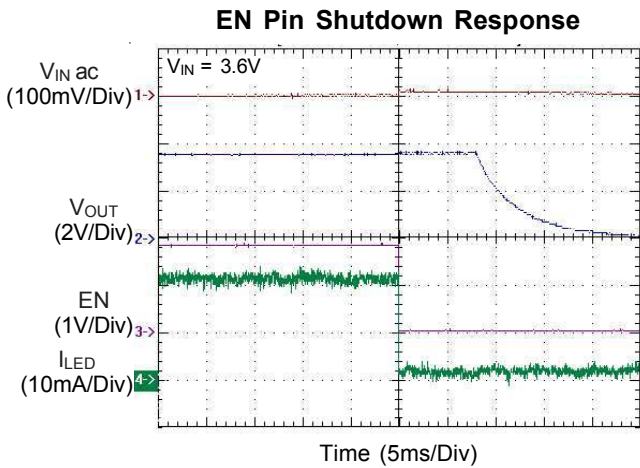
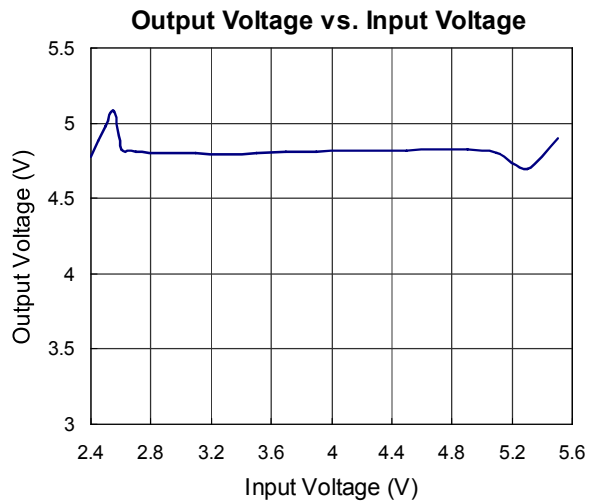
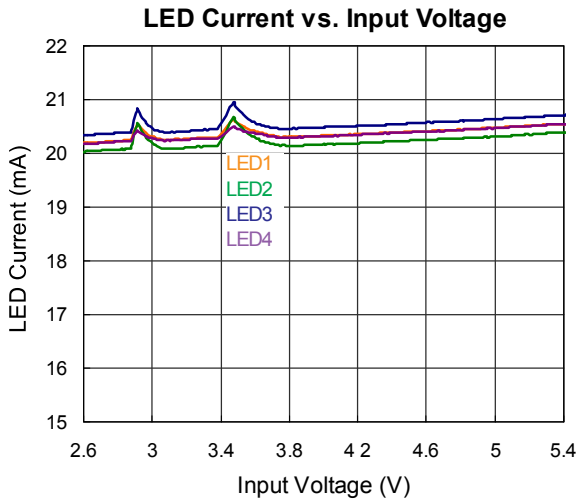
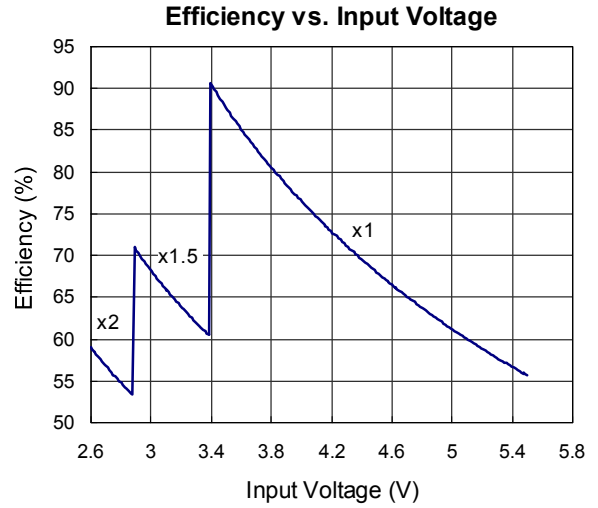
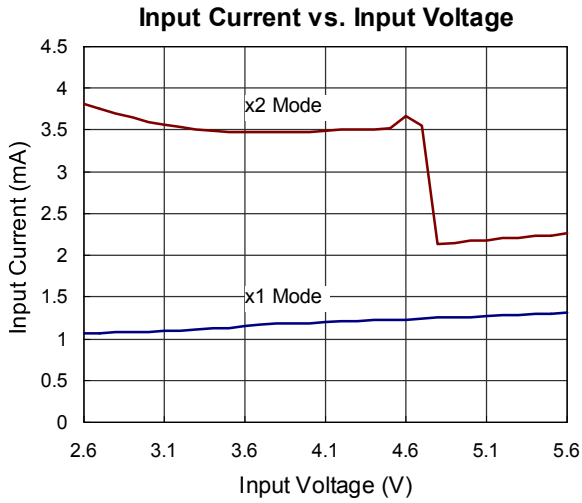

**x1.5 Mode Ripple & Spike**

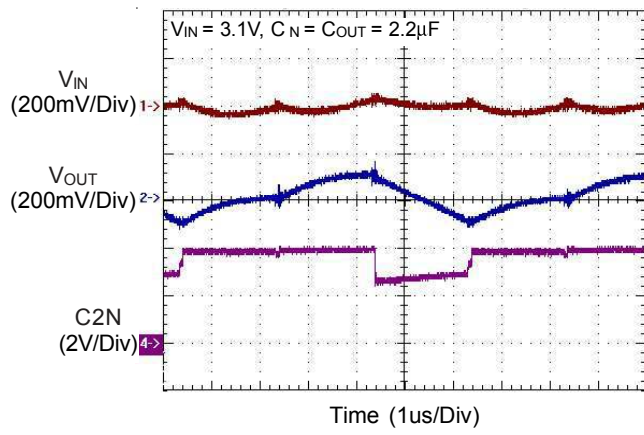

**x2 Mode Ripple & Spike**

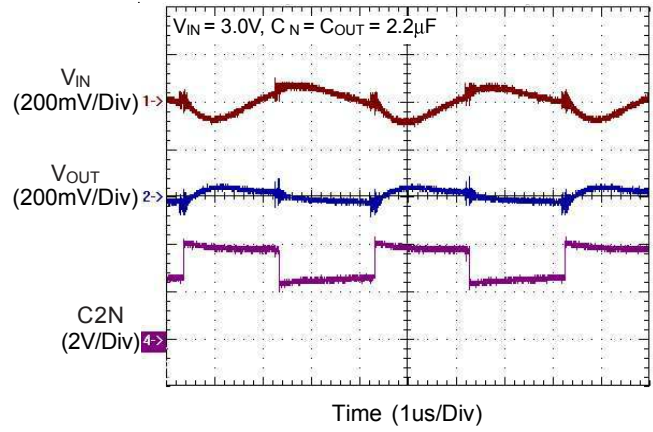

## Applications Information

The RT9368 is a high efficiency charge pump white LED driver. It provides 4 channels low dropout voltage current source to regulated 4 white LEDs current. For high efficiency, the RT9368 implements x1/x1.5/x2 mode charge pump. An external  $R_{SET}$  is used to set the current of white LED. RT9368 has input current regulation to reduce the input ripple.

### Soft Start

The RT9368 includes a soft start circuit to limit the inrush current at power on and mode switching. Soft start circuit holds the input current level long enough for output capacitor  $C_{OUT}$  reaching a desired voltage level. When the soft start off, the RT9368 won't sink spike current from  $V_{IN}$ .

### Mode Decision

The RT9368 uses a smart mode decision method to select the working mode for maximum efficiency. Mode decision circuit senses the output and LED voltage for up/down selection.

### Dimming Control

When an external PWM signal is connected to the EN pin, brightness of white LED is adjusted by the duty cycle.

### LED Current Setting

The current of white LED connected to RT9368 can be set by  $R_{SET}$ . Every current flows through the white LED is 250 times greater than the current of  $R_{SET}$ . The white LED can be estimated by following equation :

$$I_{LED} = \left( \frac{V_{SET}}{R_{SET}} \right) \times 250$$

Where  $V_{SET} = 1.2V$ , and  $R_{SET}$  is the resistor connected from ISET to GND.

If the LED is not used, the LEDs pin should be connected to GND. Figure 4 shows the connection for 3LEDs application, LED4 pin is connection to GND directly.

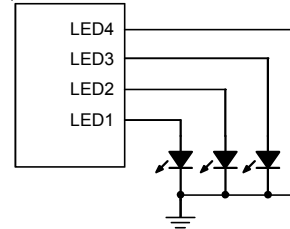

Figure 4. Application for 3 LEDs

### Layout Consideration

The RT9368 is a low dropout current source for white LED driver. Careful PCB layout is necessary. For best performance, place all peripheral components as close to the IC as possible. A short connection is highly recommended. The following guidelines should be strictly followed when designing a PCB layout for the RT9368.

- ▶ All the traces of LED pins running from chip to LEDs should be wide and short to reduce the parasitic connection resistance.
- ▶ Input capacitor ( $C_{IN}$ ) should be placed close to  $V_{IN}$  (Pin 5) and connected to ground plane. The trace of  $V_{IN}$  in the PCB should be placed far away the sensitive devices or shielded by the ground.
- ▶ The GND should be connected to a strong ground plane for heat sinking and noise protection.
- ▶ The connection of  $R_{SET}$  should be isolated from other noisy traces. The short wire is recommended to prevent EMI and noise coupling.
- ▶ Output capacitor ( $C_{OUT}$ ) should be placed close to  $V_{OUT}$  and connected to ground plane to reduce noise coupling from charge pump to LEDs.
- ▶ 6. The traces running from pins to flying capacitor should be short and wide to reduce parasitic resistance and prevent noise radiation.



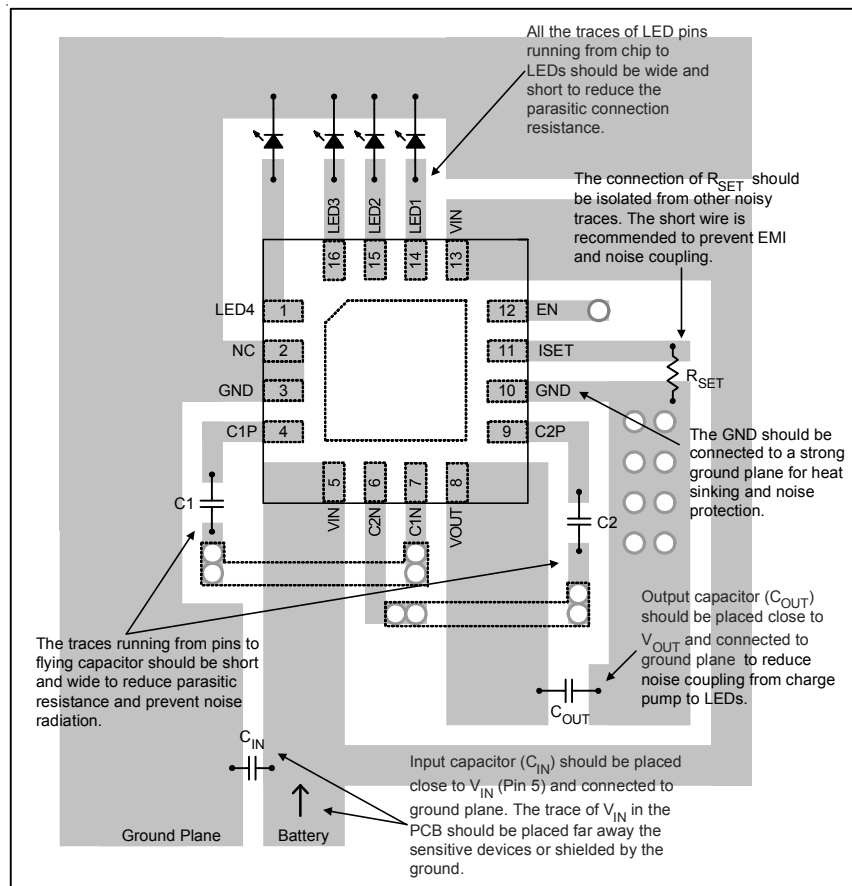
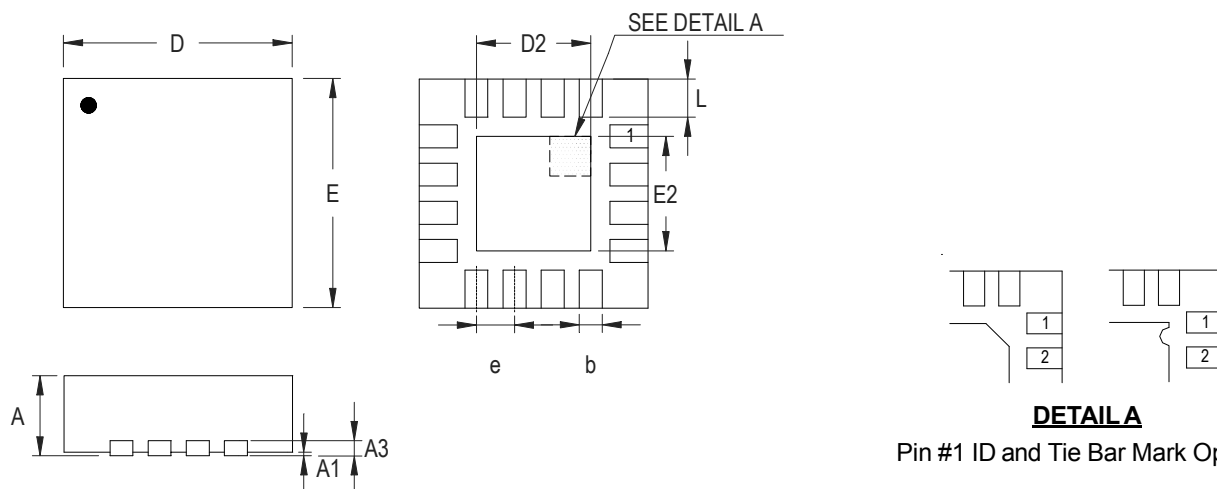

Figure 5

## Outline Dimension



Note : The configuration of the Pin #1 identifier is optional, but must be located within the zone indicated.

Symbol	Dimensions In Millimeters		Dimensions In Inches	
	Min	Max	Min	Max
A	0.700	0.800	0.028	0.031
A1	0.000	0.050	0.000	0.002
A3	0.175	0.250	0.007	0.010
b	0.180	0.300	0.007	0.012
D	2.950	3.050	0.116	0.120
D2	1.300	1.750	0.051	0.069
E	2.950	3.050	0.116	0.120
E2	1.300	1.750	0.051	0.069
e	0.500		0.020	
L	0.350	0.450	0.014	0.018

### W-Type 16L QFN 3x3 Package

#### Richtek Technology Corporation

Headquarter  
5F, No. 20, Taiyuen Street, Chupei City  
Hsinchu, Taiwan, R.O.C.  
Tel: (8863)5526789 Fax: (8863)5526611

#### Richtek Technology Corporation

Taipei Office (Marketing)  
5F, No. 95, Minchiuan Road, Hsintien City  
Taipei County, Taiwan, R.O.C.  
Tel: (8862)86672399 Fax: (8862)86672377  
Email: marketing@richtek.com

Information that is provided by Richtek Technology Corporation is believed to be accurate and reliable. Richtek reserves the right to make any change in circuit design, specification or other related things if necessary without notice at any time. No third party intellectual property infringement of the applications should be guaranteed by users when integrating Richtek products into any application. No legal responsibility for any said applications is assumed by Richtek.