

6	5	4	3	2	1
MATERIAL NO.	ENGINEERING P/N	TOTAL CIRCULAR MILL AREA (CMA)	COLOR CODE	ØA MIN	LENGTH "L" ± .025 / 0.64
191640162	SSC-2624	450 MIN / 1500 MAX	CLEAR	.065 / 1.7	1.025 / 26.0
191640163	SSC-2218	1250 MIN / 3500 MAX	RED	.105 / 2.7	1.655 / 42.0
191640164	SSC-1614	2500 MIN / 7200 MAX	BLUE	.180 / 4.5	1.655 / 42.0
191640165	SSC-1210	6100 MIN / 19000 MAX	YELLOW	.235 / 6.0	1.655 / 42.0

ⓓ

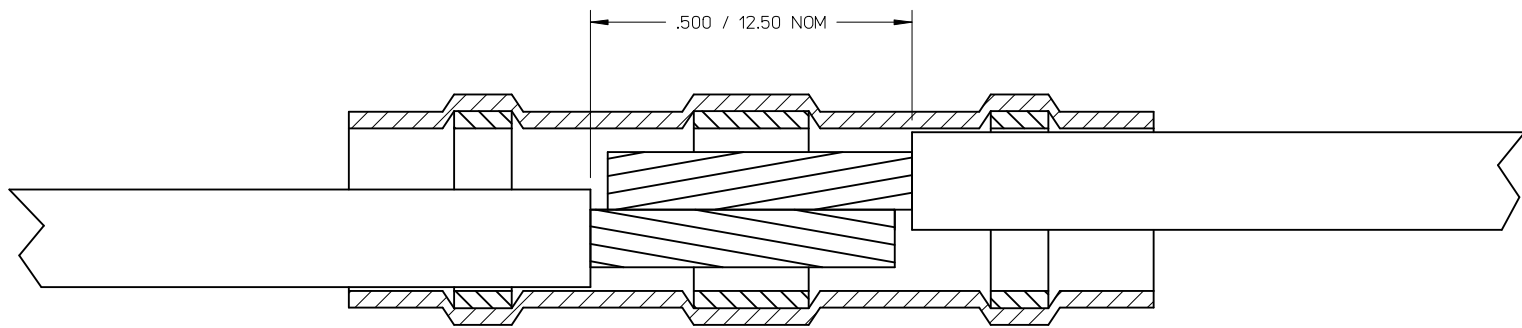
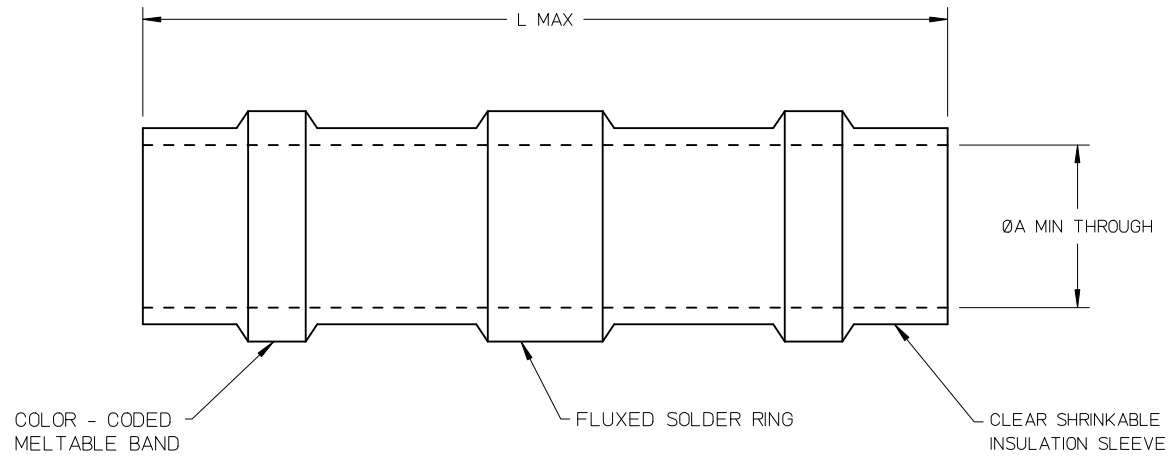

SALES DRAWING

NOTES:
 ⓓ 1. PARTS ARE NOT RoHS COMPLIANT

RMV ROHS COMPLNC	REV
EC NO: WNA2009-0740	D
DRWN:ETHRODAHL 2009/05/11	
CHKD:JMACNEIL 2009/05/11	
APPR:JMACNEIL 2009/05/12	

QUALITY SYMBOLS
▼=0
∇=0

GENERAL TOLERANCES (UNLESS SPECIFIED)	
	mm INCH
4 PLACES	± --- ± ---
3 PLACES	± --- ± .005
2 PLACES	± 0.13 ± .010
1 PLACE	± 0.25 ± ---
ANGULAR ± ---°	
DRAFT WHERE APPLICABLE MUST REMAIN WITHIN DIMENSIONS	

DIMENSION STYLE	
IN/MM	
DRAWN BY	DATE
EMF	01/20/94
CHECKED BY	DATE
APPROVED BY	DATE
MATERIAL NO.	SEE CHART
SIZE	A

SCALE	DESIGN UNITS	THIRD ANGLE PROJECTION
---	INCH	ⓐ
TITLE		
SOLDER SPLICE CONNECTOR		
MOLEX MOLEX INCORPORATED		
DOCUMENT NO.	SHEET NO.	
SD-19164-074	1 OF 1	
THIS DRAWING CONTAINS INFORMATION THAT IS PROPRIETARY TO MOLEX INCORPORATED AND SHOULD NOT BE USED WITHOUT WRITTEN PERMISSION		