

5

4

3

2

1

受控 CONTROLLED DOCUMENT

编号 P/N	CPMC8813-CUST	版本 Rev	02	日期 Rel'd Date	Jan16,12
-----------	---------------	-----------	----	------------------	----------

DRAWING NO.

CPMC8813-CUST

REVISIONS

01	OFFICAL RELEASE					
	08-17-09	J	J	T	T	
02	DIMENSIONS: $\Phi 14.3 \pm 0.3$ WAS $\Phi 14.5$ $\Phi 6.6$ WAS $\Phi 6.4$ ADD CABLE STRIP DIMENSIONS					
	12-31-11	Y	G	Y	G	M L

D

D



Description: BNC 3pc crimp plug RG223  
 Part No: CPMC8813  
 Application: For RG142,223,400,55 Cable  
 Crimp Tool: 24-9958P  
 Impedance: 50 Ohms  
 Frequency Range: 0-4 GHz  
 Material:  
 Body Zinc Nickel plated  
 Contact Brass Gold plated  
 Insulator Teflon  
 Crimp sleeve Brass Nickel plated  
 Coupling nut Zinc Nickel plated

RoHS Compliance: Yes  
 Technical Detail: Refer to Emerson Document P/N 27-0000

C

C

B

B

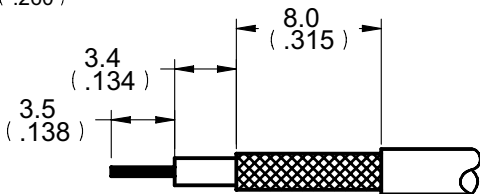
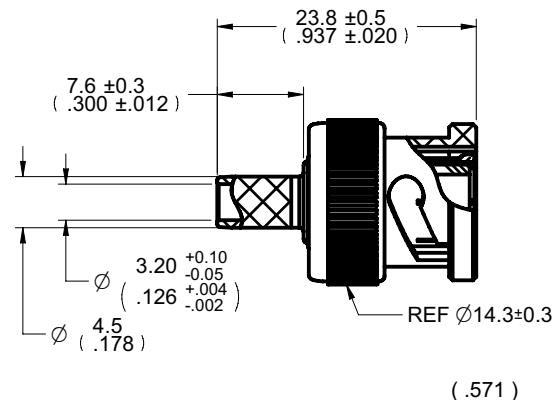
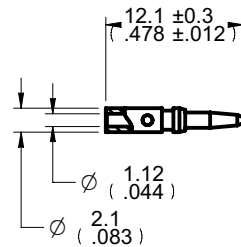
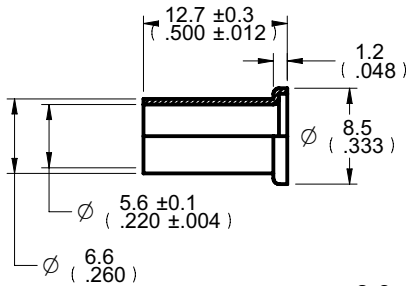

**DIM OUTLINE**

**CABLE STRIP DIMENSIONS**

CUSTOMER COPY

A

A

TOLERANCE UNLESS OTHERWISE SPECIFIED		DRAWN BY	DATE
DECIMALS	mm	JEAN.JIN	08-17-09
X	± 0.5	CHECKED BY	DATE
X.X	± 0.2	TERRY.W	08-17-09
X.XX	± 0.1	APPROVED BY	DATE
ANGLES	± 0.5°	THOMAS	08-17-09
		U/M	mm

		Connectivity Solutions	
		TITLE	
		BNC 3PC CRIMP PLUG RG223	
SHEET	DRAWING NO.	SIZE	
1 OF 1	CPMC8813-CUST	A	

THIS DRAWING WAS PRODUCED BY COMPUTER, DO NOT SCALE DRAWING OR UPDATE MANUALLY.

5

4

3

2

1