

## KP22x/Turbo MAP

### Integrated Pressure Sensor IC for Manifold Air Pressure Measurement Applications

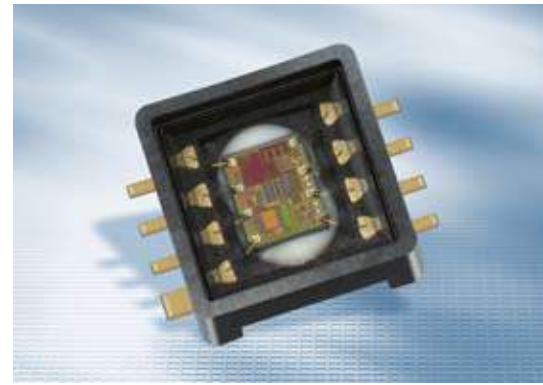

#### Application

The manifold air pressure (Turbo MAP) is an important parameter to compute the air-fuel ratio provided to the engine for lower emission due to better combustion and increased efficiency. For cost sensitive engine systems a MAP sensor show the potential to complement or even substitute mass air flow (MAF) sensors. In addition manifold pressure data can be used to compute diagnostics of leakages and malfunctions of the exhaust gas recirculation valve. In automotive applications where high production volumes are common there is substantial interest in precision, low-cost and fully integrated sensors. In this context products of the developed MAP sensor family KP22x are the optimum solution for aspirated or turbo diesel and gasoline engines management systems.

#### Features

- Absolute air pressure measurement
- Excellent accuracy over a large temperature range
- Ratiometric analog output
- Output signal fully compensated
- Pressure range from 15 to 400kPa
- Temperature range (ambient) from -40 to +140°C
- SMD package (PG-DSOF-8-16)
- Output clamping (Optional for KP226)
- Complete Product Family (KP224, KP225, KP226)

#### Typical Application

- Engine control/Turbo MAP applications
- Industrial controls



#### Application Circuit for the Pressure Sensor System

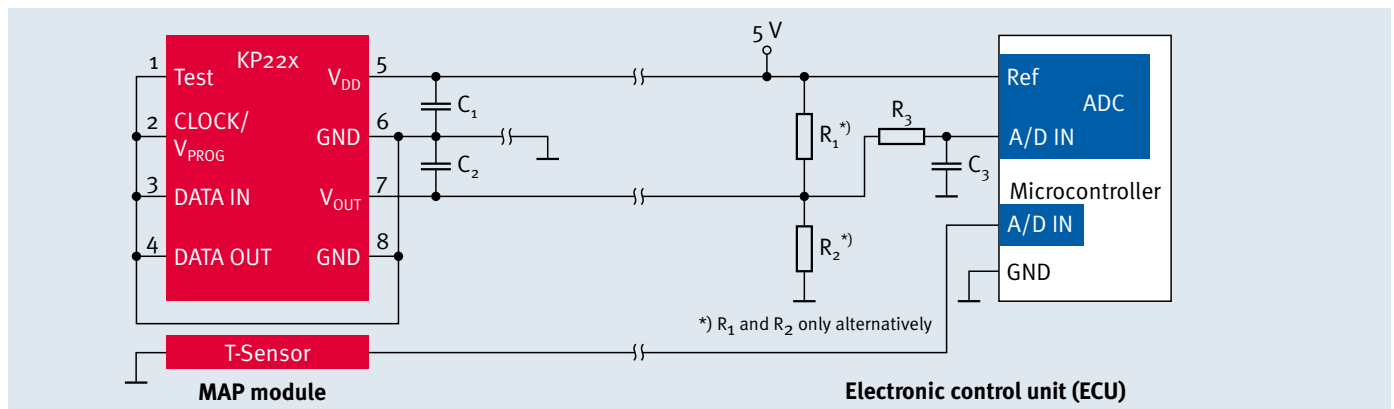

[www.infineon.com/sensors](http://www.infineon.com/sensors)

## Sensors



Never stop thinking

## Highly Integrated Sensors - Single Chip

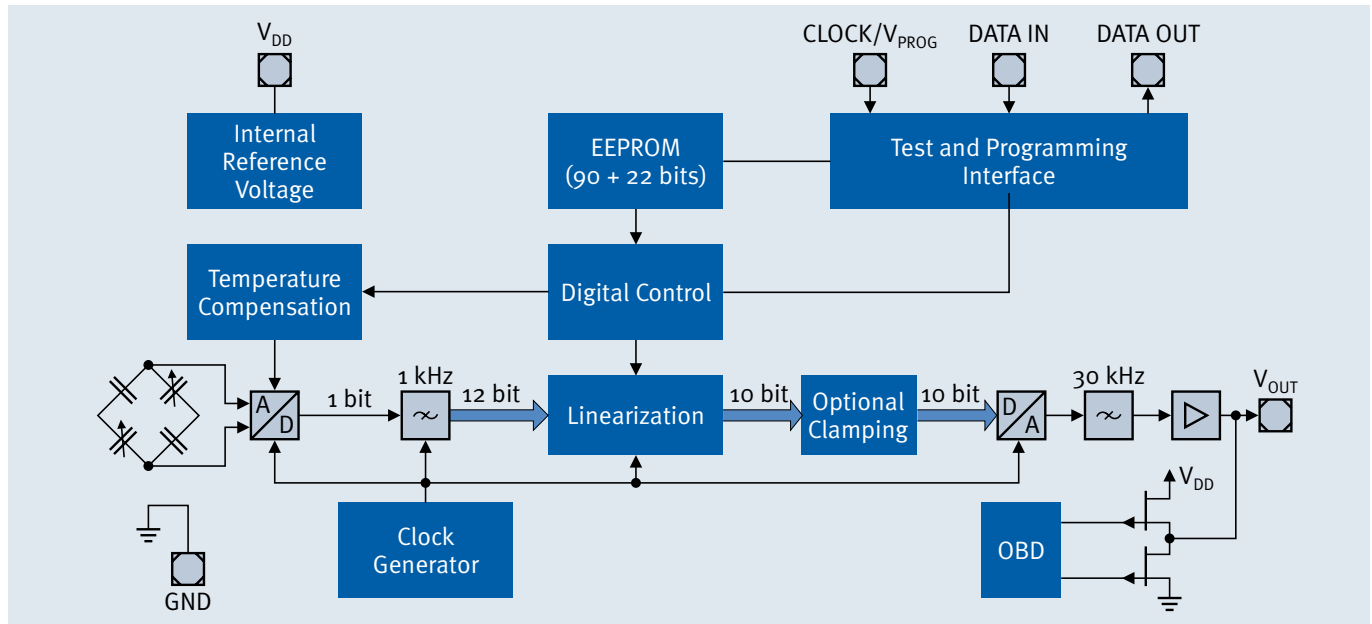

Infinion offers an extensive broad product portfolio for diesel engine management systems from micro-machined sensors to smart power ICs and microcontrollers. The KP22x pressure sensor as an integrated pressure sensor for manifold pressure measurement, is a benchmark in terms of reliability, performance and integration level.

### Product Summary

Parameter	Range			Unit
	Min.	Typ.	Max.	
Accuracy			1.0	% F.S.
Pressure Range	10		400	kPa
Sensitivity	15-5		25	mV/kPa
Supply Voltage	4-5	5.0	5.5	V
Output Current			1.0	mA
Output Voltage	0.1		4.85	V
Operating Temperature	-40		+140	°C
Programmable Transfer Functions				
Transfer Function Pressure Min	10		80	kPa
Transfer Function Pressure Max	200		400	kPa
Transfer Function Voltage Min	0,1		0.5	V
Transfer Function Voltage Max	4.5		4.85	V
Lower Programmable Clamping Level (KP226)	0.0		0.63	V
Upper Programmable Clamping Level (KP226)	4-37		5.0	V

How to reach us:  
<http://www.infineon.com>

Published by  
**Infinion Technologies AG**  
 81726 Munich, Germany

© 2008 Infineon Technologies AG  
 All Rights Reserved.

#### Legal Disclaimer

The information given in this Product Brief shall in no event be regarded as a guarantee of conditions or characteristics. With respect to any examples or hints given herein, any typical values stated herein and/or any information regarding the application of the device, Infineon Technologies hereby disclaims any and all warranties and liabilities of any kind, including without limitation, warranties of non-infringement of intellectual property rights of any third party.

#### Information

For further information on technology, delivery terms and conditions and prices, please contact the nearest Infineon Technologies Office ([www.infineon.com](http://www.infineon.com)).

#### Warnings

Due to technical requirements, components may contain dangerous substances. For information on the types in question, please contact the nearest Infineon Technologies Office.

Infinion Technologies components may be used in life-support devices or systems only with the express written approval of Infineon Technologies, if a failure of such components can reasonably be expected to cause the failure of that life-support device or system or to affect the safety or effectiveness of that device or system. Life support devices or systems are intended to be implanted in the human body or to support and/or maintain and sustain and/or protect human life. If they fail, it is reasonable to assume that the health of the user or other persons may be endangered.