

PCB LAYOUT: COMPONENT SIDE

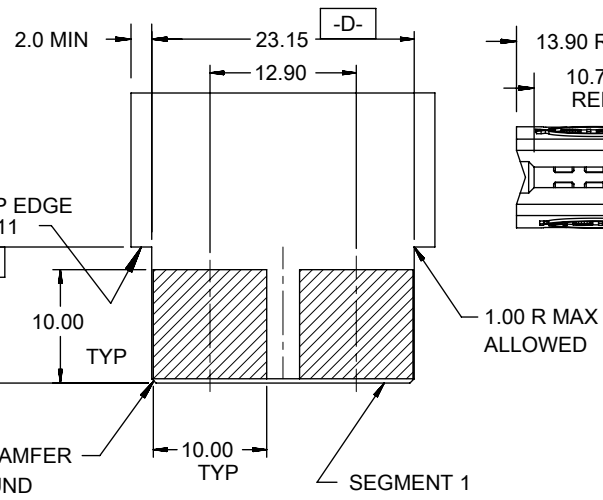

RECOMMENDED EDGE CARD LAYOUT
EDGE CARD TOLERANCE ±0.05

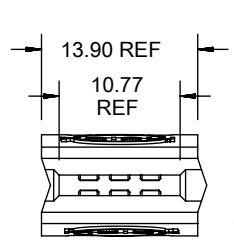

SINGLE SEGMENT MODULE
45719-1000

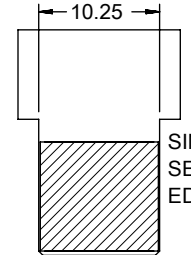

SINGLE SEGMENT EDGECARD

- NOTES:
- HOUSING MATL: LCP, UL94V-0, COLOR BLACK
TERMINAL MATL: COPPER ALLOY
 - FINISH: SELECT GOLD: 30 M.I. MIN IN CONTACT AREA
SELECT TIN: 150 M.I. MIN IN SOLDER AREA
OVERALL NICKEL UNDERPLATE.
 - PRODUCT SPECIFICATION: PS-45719-001.
 - PACKAGING SPECIFICATION: ES-45714-001.
 - PCB THICKNESS: SEE CHART
 - EDGE CARD THICKNESS: 1.57±0.08
 - DIMENSIONS GIVEN ACROSS CENTERLINES ARE SYMMETRICAL ABOUT THOSE CENTERLINES WITHIN HALF TOTAL TOLERANCE.
 - VOIDED SEGMENTS DO NOT HAVE TERMINALS IN THE TOP OR BOTTOM ROW
 - PCB HOLE SPECIFICATION: SEE PS-45719-001
 - POWER TERMINALS ARE LUBRICATED.
 - THIS EDGE WILL TOUCH HOUSING WHEN EDGE CARD IS FULLY SEATED

MATERIAL NUMBER	SEG-MENTS	VOIDED SEGMENT	P	PCB THK
45719-1000	1	NONE	4.50	3.18 OR
45719-1001	1	NONE	3.63	2.36
45719-1002	1	NONE	2.92	1.57
45719-0001	2	NONE	4.50	3.18 OR
45719-0004	2	NONE	3.63	2.36
45719-0007	2	NONE	2.92	1.57

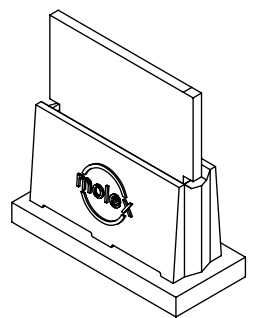

THIS DRAWING CONTAINS INFORMATION THAT IS PROPRIETARY TO MOLEX ELECTRONIC TECHNOLOGIES, LLC AND SHOULD NOT BE USED WITHOUT WRITTEN PERMISSION

DIMENSION UNITS	SCALE	CURRENT REV DESC: SLOT TOLE. UPDATE	
MM	1:1		
GENERAL TOLERANCES (UNLESS SPECIFIED)			
	MM	INCH	
4 PLACES	±	±	
3 PLACES	±	±	
2 PLACES	±	0.25	±
1 PLACE	±	0.25	±
0 PLACES	±	±	
ANGULAR TOL		± 0.5°	
DRAFT WHERE APPLICABLE MUST REMAIN WITHIN DIMENSIONS			

EC NO: 611749	
DRWN: PKH	2019/03/01
CHK'D: MBELLE	2019/06/04
APPR: HTHYAGARAJ	2019/06/14
INITIAL REVISION:	
DRWN: MARGULIS	2003/11/11
APPR: MARGULIS	2003/11/11

molex

POWER EDGE ASSEMBLY
POWER VERTICAL SOLDER TAIL

PRODUCT CUSTOMER DRAWING

DOCUMENT NUMBER	DOC TYPE	DOC PART	REVISION
SD-45719-001	PSD	001	H

NOTES:
1. FOR ALL OTHER DIMENSIONS AND NOTES SEE SHEET 1.

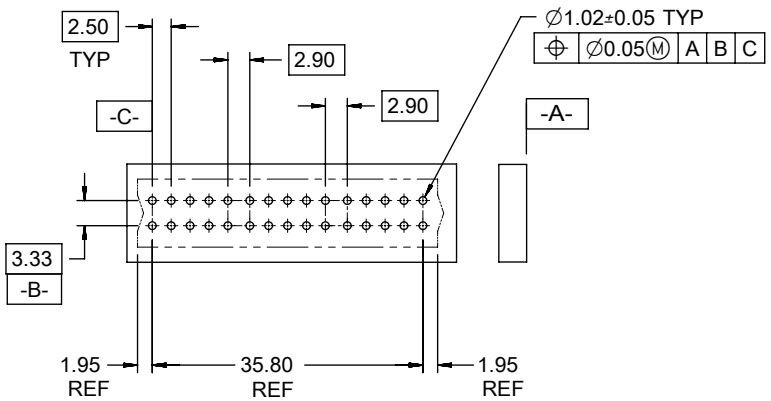
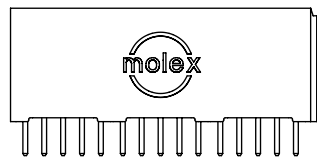
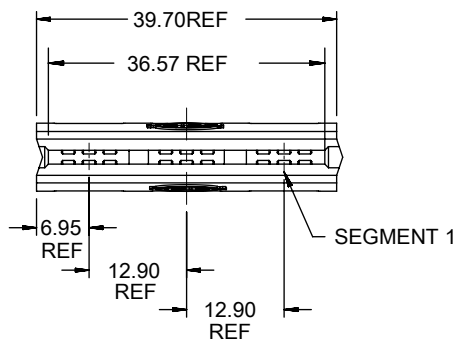

PCB LAYOUT: COMPONENT SIDE

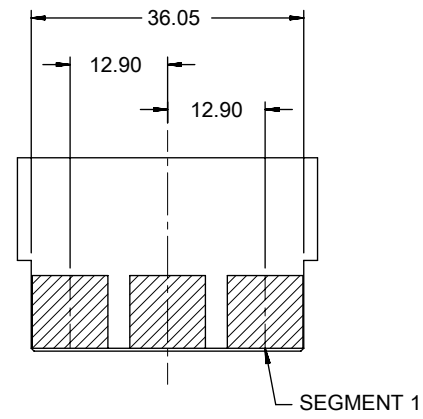

RECOMMENDED EDGE CARD LAYOUT
EDGE CARD TOLERANCE: ±0.05

MATERIAL NUMBER	VOIDED SEGMENT	P	PCB THK
45719-0002	NONE	4.50	3.18
45719-3001	1		
45719-3002	2		
45719-3003	3		
45719-3004	1,2		
45719-3005	1,3		
45719-3006	2,3		
45719-0005	NONE	3.63	2.36
45719-3007	1		
45719-3008	2		
45719-3009	3		
45719-3010	1,2		
45719-3011	1,3		
45719-3012	2,3		
45719-0008	NONE	2.92	1.57
45719-3013	1		
45719-3014	2		
45719-3015	3		
45719-3016	1,2		
45719-3017	1,3		
45719-3018	2,3		

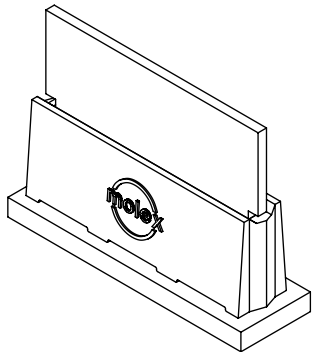

THIS DRAWING CONTAINS INFORMATION THAT IS PROPRIETARY TO MOLEX ELECTRONIC TECHNOLOGIES, LLC AND SHOULD NOT BE USED WITHOUT WRITTEN PERMISSION

DIMENSION UNITS MM	SCALE 1:1	CURRENT REV DESC: SLOT TOLE. UPDATE	
GENERAL TOLERANCES (UNLESS SPECIFIED)		EC NO: 611749	
	MM INCH	DRWN: PKH	2019/03/01
4 PLACES	± ±	CHK'D: MBELLE	2019/06/04
3 PLACES	± ±	APPR: HTHYAGARAJ	2019/06/14
2 PLACES	± 0.25 ±	INITIAL REVISION:	
1 PLACE	± 0.25 ±	DRWN: MARGULIS	2003/11/11
0 PLACES	± ±	APPR: MARGULIS	2003/11/11
ANGULAR TOL	± 0.5 °	DRAFT WHERE APPLICABLE MUST REMAIN WITHIN DIMENSIONS	



**POWER EDGE ASSEMBLY
POWER VERTICAL SOLDER TAIL**

PRODUCT CUSTOMER DRAWING

DOCUMENT NUMBER	DOC TYPE	DOC PART	REVISION
SD-45719-001	PSD	001	H

FORMAT: Eng/lega-master-0b-prod-A
REVISION: D
DATE: 2018/01/18

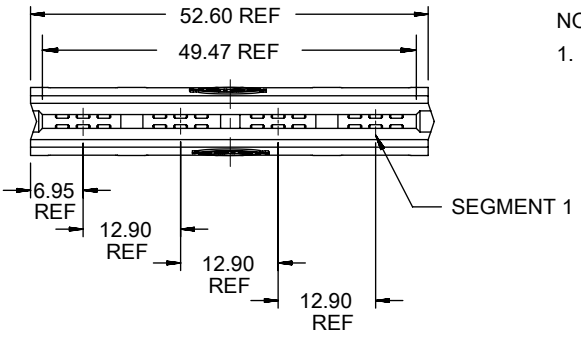

NOTES:
1. FOR ALL OTHER DIMENSIONS AND NOTES SEE SHEET 1.

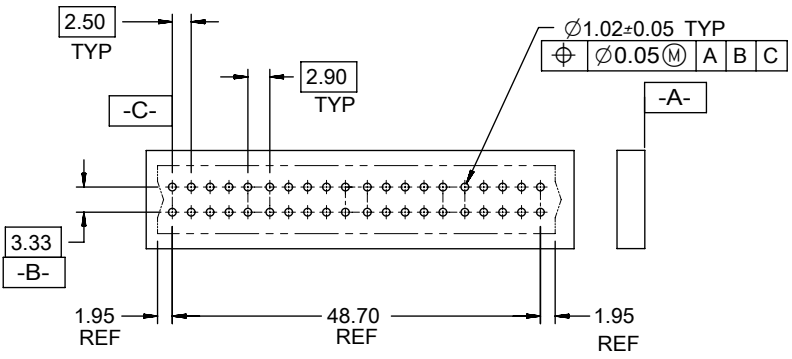
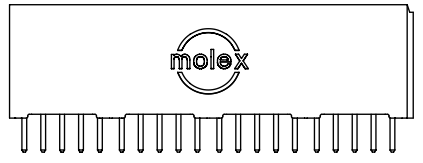

PCB LAYOUT: COMPONENT SIDE

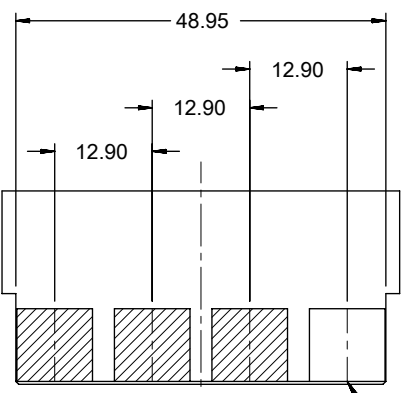

RECOMMENDED EDGE CARD LAYOUT
EDGE CARD TOLERANCE: ±0.05

MATERIAL NUMBER	VOIDED SEGMENT	P	PCB THK
45719-0003	NONE	4.50	3.18
45719-4001	1		
45719-4002	2		
45719-4003	3		
45719-4004	4		
45719-4005	1, 2		
45719-4006	1, 3		
45719-4007	1, 4		
45719-4008	2, 3		
45719-4009	2, 4		
45719-4010	3, 4		
45719-0006	NONE	3.63	2.36
45719-4011	1		
45719-4012	2		
45719-4013	3		
45719-4014	4		
45719-4015	1, 2		
45719-4016	1, 3		
45719-4017	1, 4		
45719-4018	2, 3		
45719-4019	2, 4		
45719-4020	3, 4		
45719-0009	NONE	2.92	1.57
45719-4021	1		
45719-4022	2		
45719-4023	3		
45719-4024	4		
45719-4025	1, 2		
45719-4026	1, 3		
45719-4027	1, 4		
45719-4028	2, 3		
45719-4029	2, 4		
45719-4030	3, 4		

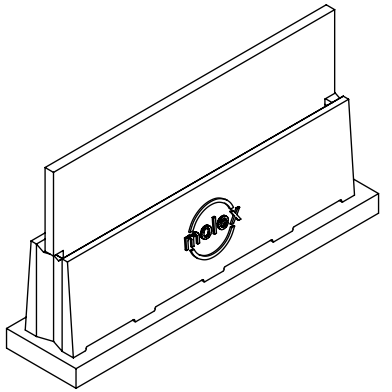

THIS DRAWING CONTAINS INFORMATION THAT IS PROPRIETARY TO MOLEX ELECTRONIC TECHNOLOGIES, LLC AND SHOULD NOT BE USED WITHOUT WRITTEN PERMISSION

DIMENSION UNITS MM	SCALE 1:1	CURRENT REV DESC: SLOT TOLE. UPDATE	
GENERAL TOLERANCES (UNLESS SPECIFIED)		EC NO: 611749	
	MM INCH	DRWN: PKH	2019/03/01
4 PLACES	± ±	CHK'D: MBELLE	2019/06/04
3 PLACES	± ±	APPR: HTHYAGARAJ	2019/06/14
2 PLACES	± 0.25 ±	INITIAL REVISION:	
1 PLACE	± 0.25 ±	DRWN: MARGULIS	2003/11/11
0 PLACES	± ±	APPR: MARGULIS	2003/11/11
ANGULAR TOL	± 0.5 °		

molex

POWER EDGE ASSEMBLY
POWER VERTICAL SOLDER TAIL

PRODUCT CUSTOMER DRAWING

DOCUMENT NUMBER	DOC TYPE	DOC PART	REVISION
SD-45719-001	PSD	001	H