

IDS-3119

19" SXGA Industrial Open Frame Monitor

NEW



Features

- 19" SXGA LCD panel with LED backlight for 20% power saving and environmental protection
- 0° C ~ +45° C operating temperature
- 5-wire resistive touch screen solution
- Combo touch interface of RS232 and USB
- Dual signal interface with VGA & DVI
- Integrated bracket for easy installation
- Versatile mounting methods for rear mounting and VESA mounting
- Anti-Reflective treatment (optional)
- Ultra high brightness solution of 1200 cd/m² for outdoor application (optional)

Introduction

The Advantech IDS-3119 Embedded Open Frame Monitor series offers flexible options for LCD, touchscreen, signal interface and chassis mounting. The series supports rear and VESA mounting. The integrated brackets bring the benefits of easy installation and provide flexibility for different applications.

Specifications

Display	Model	IDS-3119
	Size	19" LED panel
	Resolution	1280 x 1024 (SXGA)
	Viewing Angle	85°/85° (H), 80°/80° (V)
	Brightness	350 (cd/m ²)
	Color Support	16.7M colors
	Contrast Ratio	1000:1
	Response Time	5 [msec]
Touchscreen	Backlight Life (hrs)	50,000 hrs
	T/S Type	5-Wire Resistive Touch Screen
	Surface Hardness	3H
	Durability	10 million touches
Environment	Transparency	80% ± 3%
	Operating Temperature	0~ 45° C (32 ~ 113° F)
	Storage Temperature	-20 ~ 60° C (-4 ~ 140° F)
	Humidity	5 ~ 90% @ 40° C, non-condensing
System	Vibration	5-500Hz, 0.026G ² /Hz, 2.16Grms, X, Y, Z 1 hour per axis
	I/O	VGA x1; DVI-D x 1; 12 VDC Jack x 1; USB x 1; RS232 x 1 (USB & RS232 are reserved for the Connection to enable touch usage only)
	OSD	Keys; Menu, Up, Down, Auto Adjust, Monitor Power on/off Menu Functions: Brightness, Contrast, Screen Setting, Color Temp, Language OSD Settings, VGA/DVI, Recall, Auto Adjust
	Power	60 W power adapter, with AC 100 ~ 240 V input and DC +12 V @ 5 A output
	EMC Compliance	CE/FCC/CCC

Dimensions

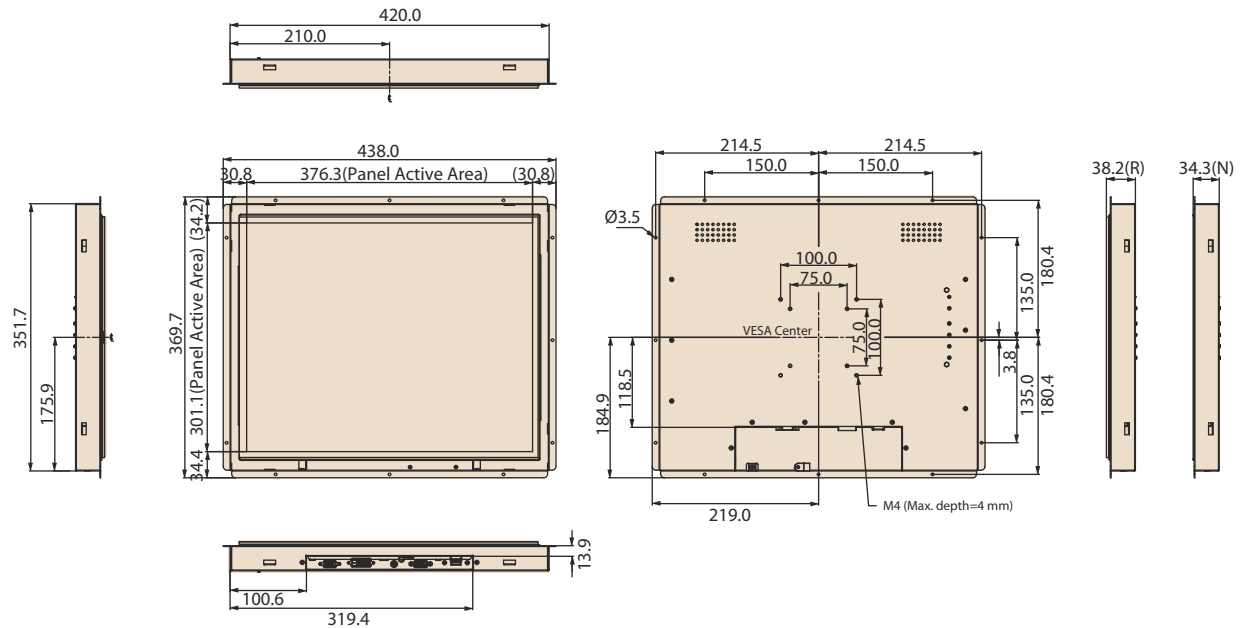

Packing List

Part Number	Description
1700002215	1 x M Cable USB-A(M)/USB-A(M) 180CM
1700021332-01	1 x VGA cable 15P(M) 1.8 meter
1962055040	8 x Clamper
1935042520	8 x Screw of clamper M4_25L
1992610005	1 x Cable clamp
1933030500	1 x Screw of cable clamp
1992602010	1 x Cable tie

* USB Cable is only included in IDS-3119R series.

Note: Package contents are subject to change without prior notice

Optional Items

Part Number	Description
1702002600	3-Pin power cord (USA)
1700000596	3-Pin power cord (China)
1700018705	3-Pin power cord (EU)
1700018704	3-Pin Power Cord (UK)
1700000237	3-Pin Power Cord with PSE (Japan)
96PSA-A60W12R1-3	ADAPTER AC100-240V 60W +12V/5A
1700000243	DVI cable 2.0 meter
1700091800	CABLE 9P/9P 1.8M M/F (T/S RS232 Cable)

Ordering Information

Model Name	Description
IDS-3119N-35SXA1E	19" SXGA 350 cd/m ² LED Open Frame Monitor
IDS-3119R-35SXA1E	19" SXGA 350 cd/m ² LED Open Frame Touch Monitor