

## The RF Line NPN Silicon Power Transistor 80W, 3.0-200MHz, 28V

M/A-COM Products  
Released - Rev. 07.07

Designed primarily for wideband large-signal output amplifier stages in the 30–200 MHz frequency range.

- Guaranteed performance at 150 MHz, 28 Vdc  
Output power = 80 W  
Minimum gain = 10 dB
- Built-in matching network for broadband operation
- 100% tested for load mismatch at all phase angles with 30:1 VSWR
- Gold metallization system for high reliability applications

### Product Image

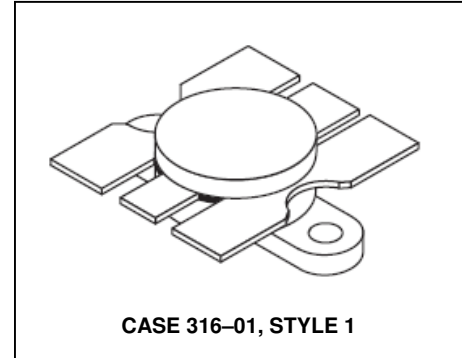

### MAXIMUM RATINGS

Rating	Symbol	Value	Unit
Collector–Emitter Voltage	$V_{CEO}$	35	Vdc
Collector–Base Voltage	$V_{CBO}$	65	Vdc
Emitter–Base Voltage	$V_{EBO}$	4.0	Vdc
Collector Current — Continuous Peak	$I_C$	9.0 13.5	Adc
Total Device Dissipation @ $T_C = 25^\circ\text{C}$ (1) Derate above $25^\circ\text{C}$	$P_D$	220 1.26	Watts W/ $^\circ\text{C}$
Storage Temperature Range	$T_{stg}$	–65 to +150	$^\circ\text{C}$

### THERMAL CHARACTERISTICS

Characteristic	Symbol	Max	Unit
Thermal Resistance, Junction to Case	$R_{\theta JC}$	0.8	$^\circ\text{C/W}$

### ELECTRICAL CHARACTERISTICS ( $T_C = 25^\circ\text{C}$ unless otherwise noted.)

Characteristic	Symbol	Min	Typ	Max	Unit
----------------	--------	-----	-----	-----	------

### OFF CHARACTERISTICS

Collector–Emitter Breakdown Voltage ( $I_C = 50\text{ mAdc}$ , $I_B = 0$ )	$V_{(BR)CEO}$	35	—	—	Vdc
Collector–Emitter Breakdown Voltage ( $I_C = 50\text{ mAdc}$ , $V_{BE} = 0$ )	$V_{(BR)CES}$	65	—	—	Vdc
Collector–Base Breakdown Voltage ( $I_C = 50\text{ mAdc}$ , $I_E = 0$ )	$V_{(BR)CBO}$	65	—	—	Vdc
Emitter–Base Breakdown Voltage ( $I_E = 5.0\text{ mAdc}$ , $I_C = 0$ )	$V_{(BR)EBO}$	4.0	—	—	Vdc
Collector Cutoff Current ( $V_{CB} = 30\text{ Vdc}$ , $I_E = 0$ )	$I_{CBO}$	—	—	5.0	mAdc

The RF Line NPN Silicon Power Transistor  
80W, 3.0-200MHz, 28V

M/A-COM Products  
Released - Rev. 07.07

### ON CHARACTERISTICS

DC Current Gain ( $I_C = 4.0 \text{ Adc}$ , $V_{CE} = 5.0 \text{ Vdc}$ )	$h_{FE}$	10	—	80	—
---	----------	----	---	----	---

### DYNAMIC CHARACTERISTICS

Output Capacitance ( $V_{CB} = 28 \text{ Vdc}$ , $I_E = 0$ , $f = 1.0 \text{ MHz}$ )	$C_{ob}$	—	100	130	pF
---	----------	---	-----	-----	----

NOTE: (continued)  
1. This device is designed for RF operation. The total device dissipation rating applies only when the device is operated as an RF amplifier.

### ELECTRICAL CHARACTERISTICS — continued ( $T_C = 25^\circ\text{C}$ unless otherwise noted.)

Characteristic	Symbol	Min	Typ	Max	Unit
----------------	--------	-----	-----	-----	------

### NARROW BAND FUNCTIONAL TESTS (Figure 1)

Common-Emitter Amplifier Power Gain ( $V_{CC} = 28 \text{ Vdc}$ , $P_{out} = 80 \text{ W}$ , $f = 150 \text{ MHz}$ )	$G_{PE}$	10	13	—	dB
Collector Efficiency ( $V_{CC} = 28 \text{ Vdc}$ , $P_{out} = 80 \text{ W}$ , $f = 150 \text{ MHz}$ )	$\eta$	55	—	—	%
Load Mismatch ( $V_{CC} = 28 \text{ Vdc}$ , $P_{out} = 80 \text{ W CW}$ , $f = 150 \text{ MHz}$ , $VSWR = 30:1$ all phase angles)	$\psi$	No Degradation in Output Power			

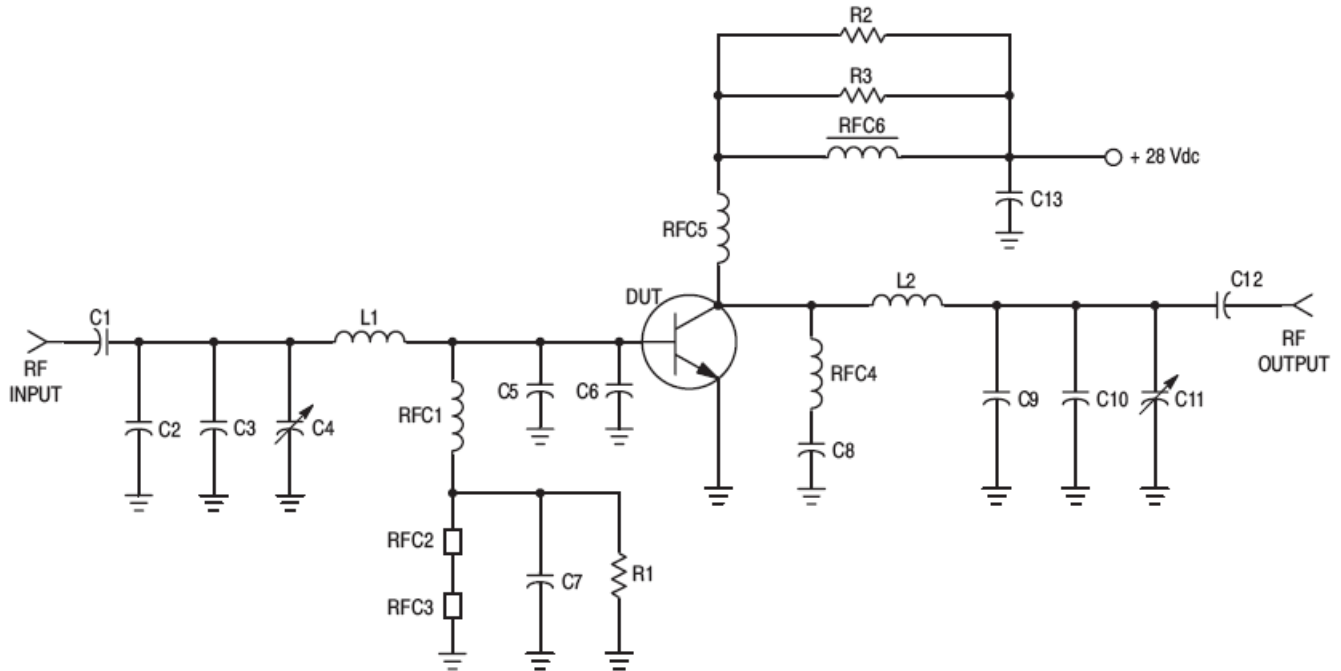

C1 — 22 pF 100 mil ATC  
 C2, C3 — 24 pF 100 mil ATC  
 C4, C11 — 0.8–20 pF JMC #5501 Johanson  
 C5 — 200 pF 100 mil ATC  
 C6 — 240 pF 100 mil ATC  
 C7 — Dipped Mica 1000 pF  
 C8 — 0.1  $\mu$ F Erie Red Cap  
 C9, C10, C12 — 30 pF 100 mil ATC  
 C13 — 1.0  $\mu$ F Tantalum

L1 — 0.8", #20 Wire  
 L2 — 1.0", #20 Wire  
 RFC1, RFC4 — 0.15  $\mu$ H Molded Coil  
 RFC2, RFC3 — Ferroxcube Bead 56–590–65–3B  
 RFC5 — 2.5", #20 Wire, 1.5 Turns  
 RFC6 — Ferroxcube VK200–19/4B  
 R1 — 10  $\Omega$ , 1/2 W  
 R2, R3 — 10  $\Omega$ , 1.0 W

Figure 1. 150 MHz Test Amplifier

### TYPICAL PERFORMANCE CURVES

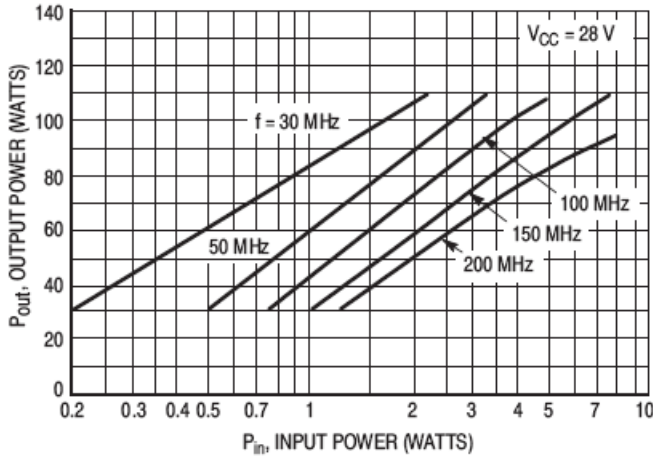

Figure 2. Output Power versus Input Power

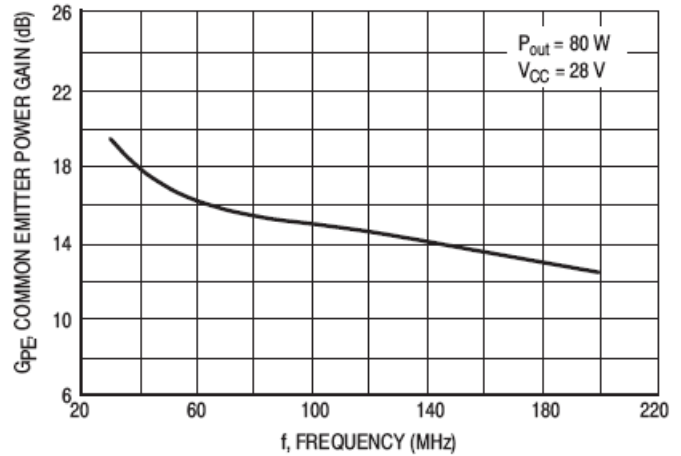

Figure 3. Power Gain versus Frequency

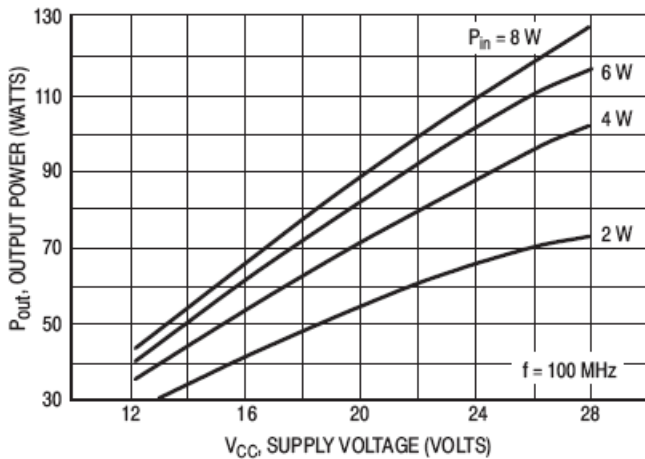

Figure 4. Output Power versus Supply Voltage

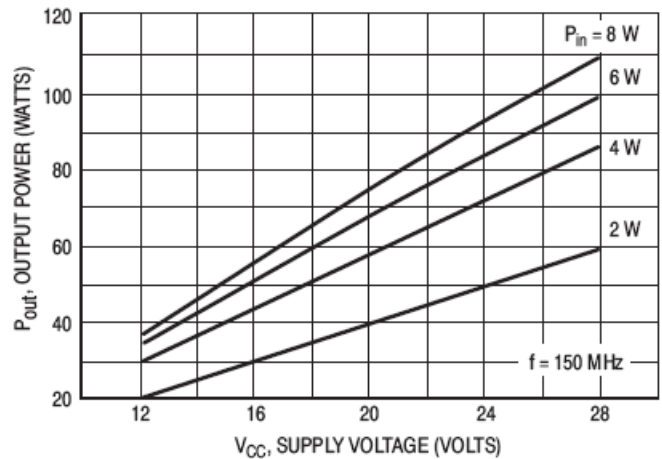

Figure 5. Output Power versus Supply Voltage

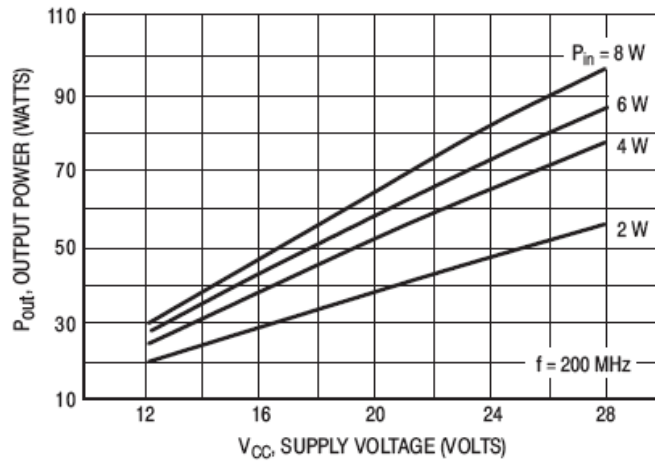

Figure 6. Output Power versus Supply Voltage

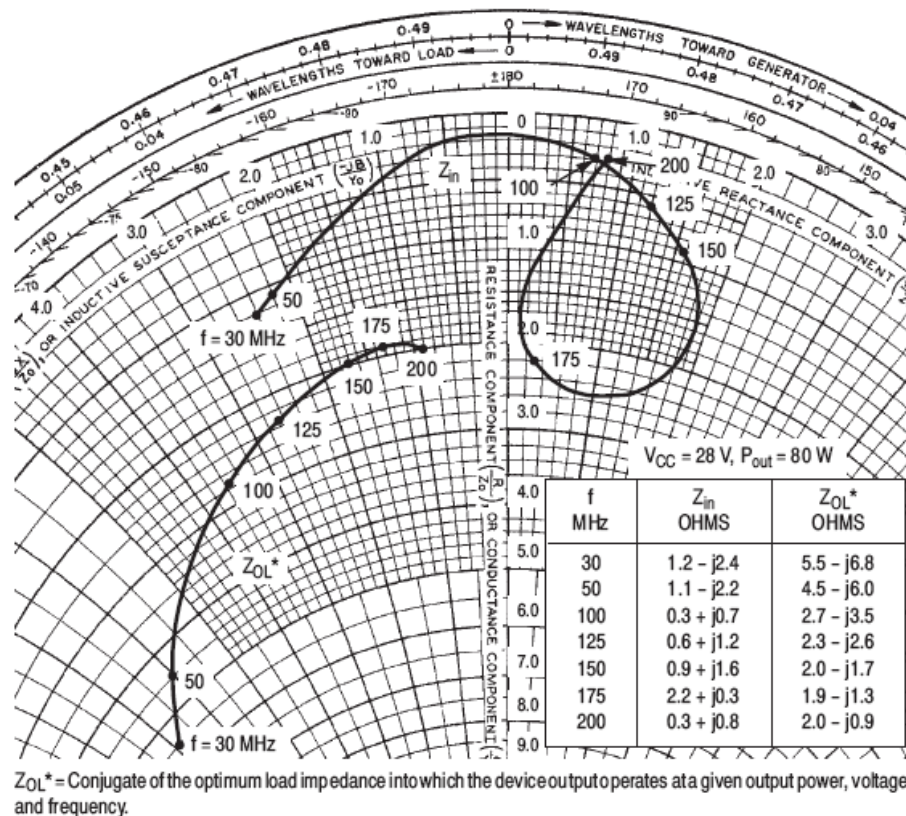

Figure 7. Series Equivalent Input-Output Impedance

## PACKAGE DIMENSIONS

