

Advanced PWM Motor Controller

FEATURES

- Single or Dual Supply Operation
- Accurate High Speed Oscillator
- Differential X5 Current Sense Amplifier
- Bidirectional Pulse-by-Pulse Current Limiting
- Programmable Oscillator Amplitude and PWM Deadband
- Dual 500mA Totem Pole Output Drivers
- Dual 60V, 50mA Open Collector Drivers
- Undervoltage Lockout

DESCRIPTION

The UC1638 family of integrated circuits are advanced pulse width modulators intended for a variety of PWM motor drive and amplifier applications requiring either uni-directional or bi-directional drive circuits. Similar in architecture to the UC1637, all necessary circuitry is included to generate an analog error signal and modulate two bi-directional pulse train outputs in proportion to the error signal magnitude and polarity.

Key features of the UC1638 include a programmable high speed triangle oscillator, a 5X differential current sensing amplifier, a high slew rate error amplifier, high speed PWM comparators, and two 50mA open collector as well as two $\pm 500\text{mA}$ totem pole output stages. The individual circuit blocks are designed to provide practical operation to switching frequencies of 500kHz.

Significant improvements in circuit speed, elimination of many external programming components, and the inclusion of a differential current sense amplifier, allow this controller to be specified for higher performance applications, yet maintain the flexibility of the UC1637. The current sense amplifier in conjunction with the error amplifier can be configured for average current feedback. The additional open collector outputs provide a drive signal

continued

BLOCK DIAGRAM

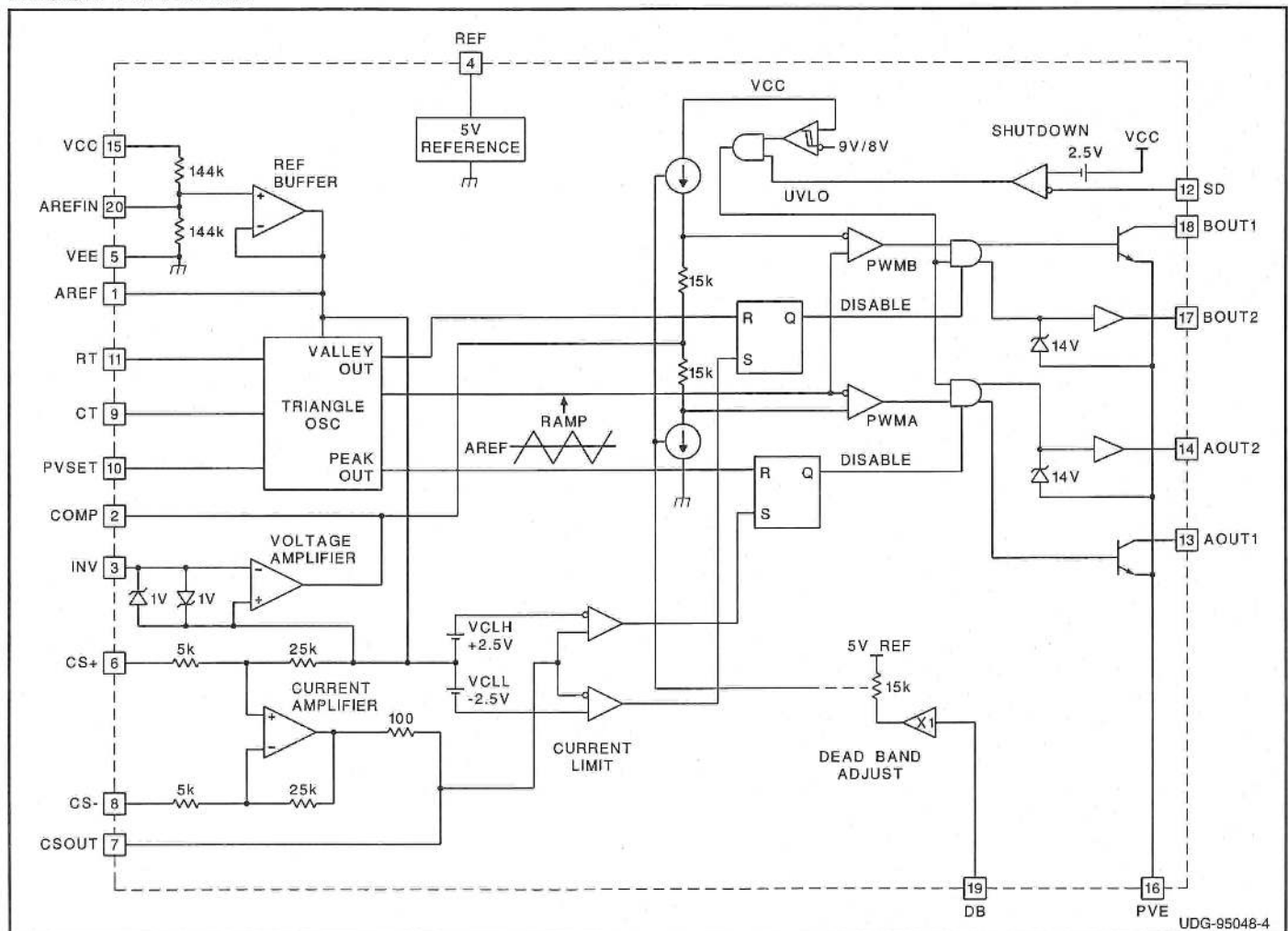

DESCRIPTION (cont.)

for the highside switches in a full bridge configuration. The programmable AREFIN pin allows for single or dual supply operation. Oscillator ramp amplitude and PWM deadband are programmable by tapping a voltage divider off the 5V reference to the appropriate programming input (PVSET or DB).

Additional features include a precision externally available 5V reference, undervoltage lockout, pulse-by-pulse peak current limiting, and a remote shutdown port. The UC1638 family is available in the 20 pin N, DW and J packages. Consult the factory for other packaging options.

ABSOLUTE MAXIMUM RATINGS

Supply Voltage VCC (referenced to VEE)	40V
Output Drivers (AOUT2, BOUT2)	
Currents (continuous)	±0.25A
Currents (peak)	±500mA
REF Output Current	Internally Limited
PVSET, DB, RT, INV, REF, CSOUT	0.3 to 10V
CS+, CS-	VEE-1V to VCC
CT, AREF, AREFIN, COMP, SD	VEE - 0.3
Output Voltage (AOUT1, BOUT1)	60V
Storage temperature	-65°C to +150°C
Junction Temperature	-55°C to +150°C
Lead temperature (soldering, 10 sec.)	+300°C

Currents are positive into, negative out of the specified terminal. Consult packaging section of data book for thermal limitation considerations of packages.

CONNECTION DIAGRAMS

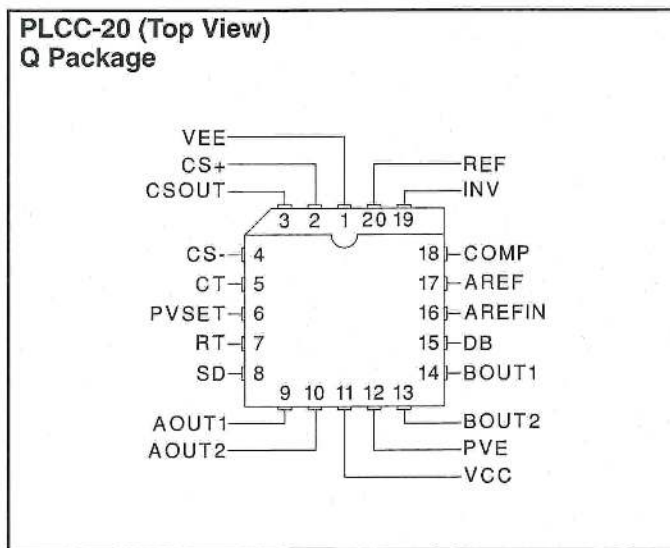
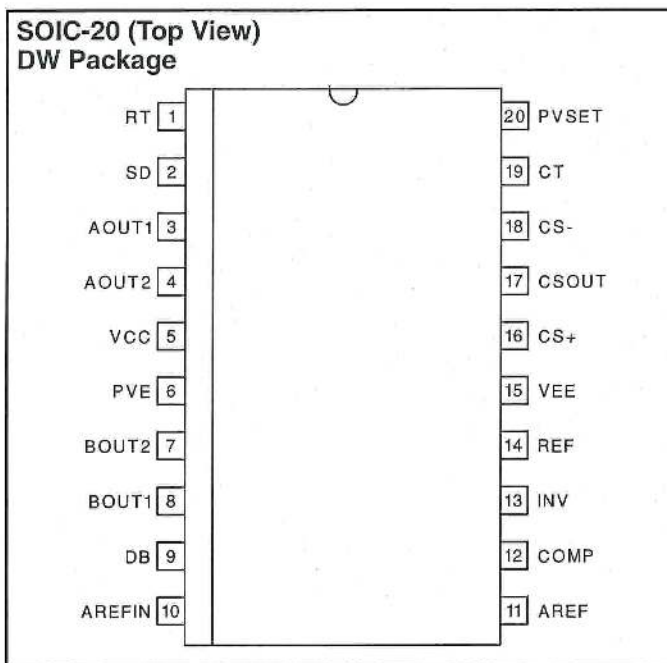
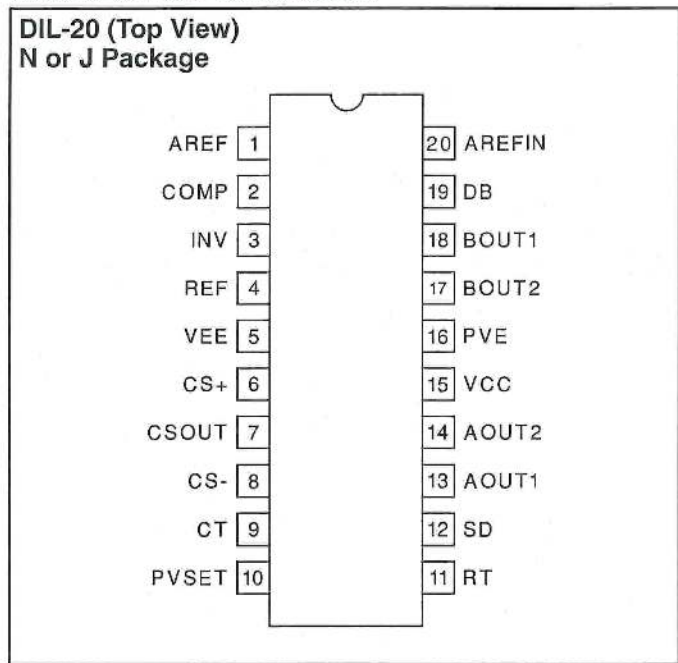

ELECTRICAL CHARACTERISTICS

Unless otherwise specified; VCC = 15V, VEE = -15V, CT = 680pF, RT = 3k, VPVSET = 1.5V, VCOMP = 0V, VCSOUT = 0V, VDB = REF, VEXTREF = 0V, VSD = VCC - 3V, TA = -55°C to 125°C for the UC1638, -25°C to 85°C for the UC2638, 0°C to 70°C for the UC3638. TA = TJ.

PARAMETER	TEST CONDITIONS	MIN	TYP	MAX	UNITS
Overall					
Supply Current, Operating			15	23	mA
UVLO Threshold	Reference to VEE		9	10	V
UVLO Hysteresis	Reference to VEE		1		V
Voltage Amplifier					
Input Offset Voltage	COMP = 0V	-20	0	20	mV
VSENSE Bias Current		0	0.5	2	μA
Open Loop Gain	COMP = -5V to +5V	75	100		dB
CMRR	VCM = -5V to +5V	70	100		dB
PSRR	VCM = 0V, VCC - VEE = 10V to 36V	70	90		dB
VOUT High	INV = -0.1V, RL = 10k	13	13.6		V
VOUT Low	INV = +0.1V, RL = 10k		-13.8	-13	V
Slew Rate Rising and Falling	Overdrive = ±1V		12		V/μs
Output Source Current	COMP Shorted to VEE	5	15		mA
Output Sink Current	COMP Shorted to VCC	15	40		mA
Gain Bandwidth Product	FIN = 100kHz, 10mV p-p	1	5		MHz
5V Reference					
Output Voltage	IREF = -1mA, TA = 25°C	4.925	5	5.075	V
Output Voltage	IREF = -1mA	4.875	5	5.125	V
Load Regulation	IREF = -1mA to -10mA	-15	2	15	mV
Line Regulation	VCC - VEE = 10V to 36V	-15	2	15	mV
Short Circuit Current	VREF = 0V	15	70		mA
Oscillator					
Initial Accuracy	TA = 0°C - 70°C	86	98	110	kHz
Voltage Stability	VCC - VEE = 10V to 36V		2		%
Total Variation	Line, Temperature	76	98	120	kHz
PVSET Input Bias Current			0.5	3	μA
PVSET Input Voltage Range	(Note 1)	0.5		VREF	V
Amplitude Limit	(Note 1)	VEE+3		VCC-3	V
AOUT1, BOUT1 Output Drivers					
Output Low Voltage	IOUT = 1mA, Ref. to PVE, PVE = 0V		0.9	1.3	V
	IOUT = 50mA		1.2	1.8	V
Leakage Current	Output Voltage = 50V		0.1	50	μA
AOUT2, BOUT2 Output Drivers					
Output High Voltage	IOUT = -20mA, Ref. to PVE, PVE = 0V	12.2	13.5		V
	IOUT = -100mA, Ref. to PVE, PVE = 0V	12	13.5		V
Output High Clamp Level	IOUT = -20mA, Ref. to PVE, PVE = VEE		14.4	16.5	V
Output Low Voltage	IOUT = 20mA, Ref. to PVE, PVE = 0V		0.4	1	V
	IOUT = 100mA, Ref. to PVE, PVE = 0V		0.6	2.2	V
Output Rise Time	COUT = 1nF		50	100	ns
Output Fall Time	COUT = 1nF		50	100	ns

ELECTRICAL CHARACTERISTICS (continued)

Unless otherwise specified; VCC = 15V, VEE = -15V, CT = 680pF, RT = 3k, VPVSET = 1.5V, VCOMP = 0V, VCSOUT = 0V, VDB = REF, VEXTREF = 0V, VSD = VCC - 3V, TA = -55°C to 125°C for the UC1638, -25°C to 85°C for the UC2638, 0°C to 70°C for the UC3638. TA = TJ.

PARAMETER	TEST CONDITIONS	MIN	TYP	MAX	UNITS
X5 Amplifier					
Gain	V _{ID} = 100mV to 400mV	4.75	5	5.25	V/V
Common Mode Rejection	V _{CS+} , V _{CS-} = AREF ±5V	50	65		dB
-3dB Bandwidth		300	400		kHz
Slew Rate Rising		.75	1.5		V/μs
Slew Rate Falling		.75	1.5		V/μs
Shutdown					
Threshold	Ref. to VCC	-1.9	-2.25	-2.5	V
Input Bias Current	V _{SD} = SD Threshold		-0.5	-10	μA
Current Limit					
Threshold Positive	Measured Between CS+ and CS-	400	500	600	mV
Threshold Negative	Measured Between CS+ and CS-	-600	-500	-400	mV
Propagation Delay to Outputs	Overdrive = 200mV		150	250	ns
Deadband Adjust					
Maximum Deadband	V _{DB} = 0V		±5		V
Zero Deadband	V _{DB} = REF		0		V
Deadband Adjustment Gain	V _{DB} = 1V to 4V (Note 2)	±0.9	±1	±1.2	V/V
Input Bias Current	V _{DB} = VREF		3	15	μA
AREF Buffer					
Gain	AREF / VCC - VEE	0.49	0.5	0.51	V/V
Offset	(Note 3)		30	100	mV

Note 1: Oscillator triangle amplitude = $2.5 \cdot PV \pm AREF$.

Note 2: Deadband = $\pm(REF - DB)$, referenced to COMP.

Note 3: Offset = AREFIN - AREF.

PIN DESCRIPTIONS

AOUT1, BOUT1: AOUT1 and BOUT1 are open collector output drivers capable of sinking 50mA. These outputs can be pulled up to 60V maximum. With a few external components, these outputs can drive the opposite high side switches in a full bridge arrangement.

AOUT2, BOUT2: AOUT2 and BOUT2 are totem pole output drivers capable of driving external power MOSFETs directly. The peak current ratings are ±500mA. An integrated zener clamp limits the drive output amplitude to approximately 14V to prevent MOSFET gate oxide overstress. These outputs are configured to drive the opposite low side switches in a full bridge arrangement.

AREF: The voltage on AREF is simply a buffered version of the voltage on AREFIN. In single supply applications, AREF should be bypassed to VEE with a 0.1μF ceramic capacitor to provide a stable reference level for the internal circuitry.

AREFIN: The voltage on AREFIN is generated internally by a 50% voltage divider tied between VCC and VEE. As such, it provides the mid supply reference needed for the oscillator, voltage amplifier, current amplifier and current limit comparators when operating in single supply mode. A buffer amplifier is connected between AREFIN and AREF. In bipolar supply applications AREFIN is usually connected to VEE, which disables the buffer amplifier, and AREF is connected to 0V.

COMP: This is the output of the high slew rate error amplifier. The level on COMP modulates the controller duty cycle via the PWM comparators and the oscillator ramp. Compensation and DC gain setting resistors are connected between COMP and INV.

PIN DESCRIPTIONS (cont.)

CS-: This is the inverting input to the X5 current sense amplifier. The common mode input range for this pin extends from VEE-1V to VCC-4V. A low value resistor in series with the source or emitter of the low side switch in the full bridge develops the signal that is applied to this pin. At differential inputs of ±500mV typical (referenced to CS+) the controller reaches the current limit level, which truncates the output pulse.

CS+: This is the non-inverting input to the X5 current sense amplifier. The common mode input range for this pin extends from VEE-1V to VCC-4V. The characteristics for this pin are identical to CS-.

CSOUT: This is the output of the X5 current sense amplifier. Voltage levels greater than ±2.5V referenced to AREF will cause the device to enter current limit. When the CT voltage gets to within a diode drop of its peak the BOUT current limit latch gets reset and conversely when CT ramp gets to within a diode drop of the valley the AOUT current limit latch gets reset. An internal 100-Ω resistor between the amplifier output and CSOUT is provided to create a high frequency noise filter with an external capacitor to VEE. When used for average current feedback, CSOUT is summed into INV.

CT: A capacitor from CT to VEE will set the triangle oscillator frequency according to the following equation:

$$F = \frac{1}{5 \cdot RT \cdot CT}$$

The waveform on CT is symmetrical about the voltage on AREF and is applied internally to the inputs of the PWM comparators. Use a high quality ceramic capacitor with low ESL and ESR for best results. A minimum CT value of 200 pF insures good accuracy and less susceptibility to circuit layout parasitics. The oscillator and PWM are designed to provide practical operation to 500kHz.

DB: This high impedance input programs output pulse train deadtime. A stable DC voltage between 0V and REF will set a bi-directional deadband centered about the level on COMP. The deadband level is equal to: 5V - VDB. That is, 1V on DB will program ±4V of deadband centered about the COMP pin level. A convenient method for generating the programming level is a voltage divider tap off of REF.

INV: This is the inverting input to the Voltage amplifier. The common mode input range for this pin extends from VEE+2V to VCC-1V. It can be tied to a command signal generated by a rate feedback element or to a position control signal. In average current feedback applications, this input is tied to the output of the X5 current sensing amplifier (CSOUT).

PVE: This is the high current ground for the IC. The external MOSFET driver transistors are referenced to this ground. Internal level shifting circuitry gives the option of tying this pin to VEE, or the system ground in split supply applications.

PVSET: A DC voltage on PVSET programs the upper and lower thresholds for the oscillator by the following relationship:

$$V_{PK} - V_{VLY} = 5 \cdot V_{PVSET}$$

The input voltage range on PVSET is 0.5V to REF.

REF: REF is the output of the precision reference. The output is capable of supplying 15mA to peripheral circuitry and is internally short circuit current limited. Bypass REF to VEE with a 0.1μF ceramic capacitor for best performance.

RT: A single resistor from RT to VEE sets the charging and discharging currents for the triangle oscillator. The actual charge and discharge is 2X the current programmed by RT and PVSET. For best performance the current out of RT should be limited to 1mA. The voltage level on the RT pin is a buffered version of the PVSET pin voltage. Therefore, if the PVSET voltage divider is tied between VCC and VEE to incorporate line feedforward, the triangle waveform frequency will remain constant.

SD: A voltage on SD within 2.5V (typical) of VCC will cause the UC3638 to enter a UVLO condition which disables all of the driver outputs. With an external voltage divider across VCC and VEE, and a capacitor between SD and VCC, a delayed turn-on characteristic can be generated. Since the 2.5V threshold is temperature stabilized it can also be used as a higher UVLO threshold for applications which require a starting voltage higher than the internal 9V UVLO threshold.

VEE: All voltages are measured with respect to this pin. All bypass capacitors and timing components except those listed under the PVE section should be connected to this pin. Component leads should be as short and direct as possible. VEE is generally connected to the most negative voltage supply in the system. In single supply applications, VEE is tied to the system ground.

VCC: Positive supply rail for the IC. Bypass this pin to VEE and PVE with 0.1 to 1μF low ESL, ESR ceramic capacitor(s). The maximum voltage for VCC is 40V referenced to VEE. The turn on voltage level on VCC is 9V with 1V of hysteresis.

APPLICATION INFORMATION

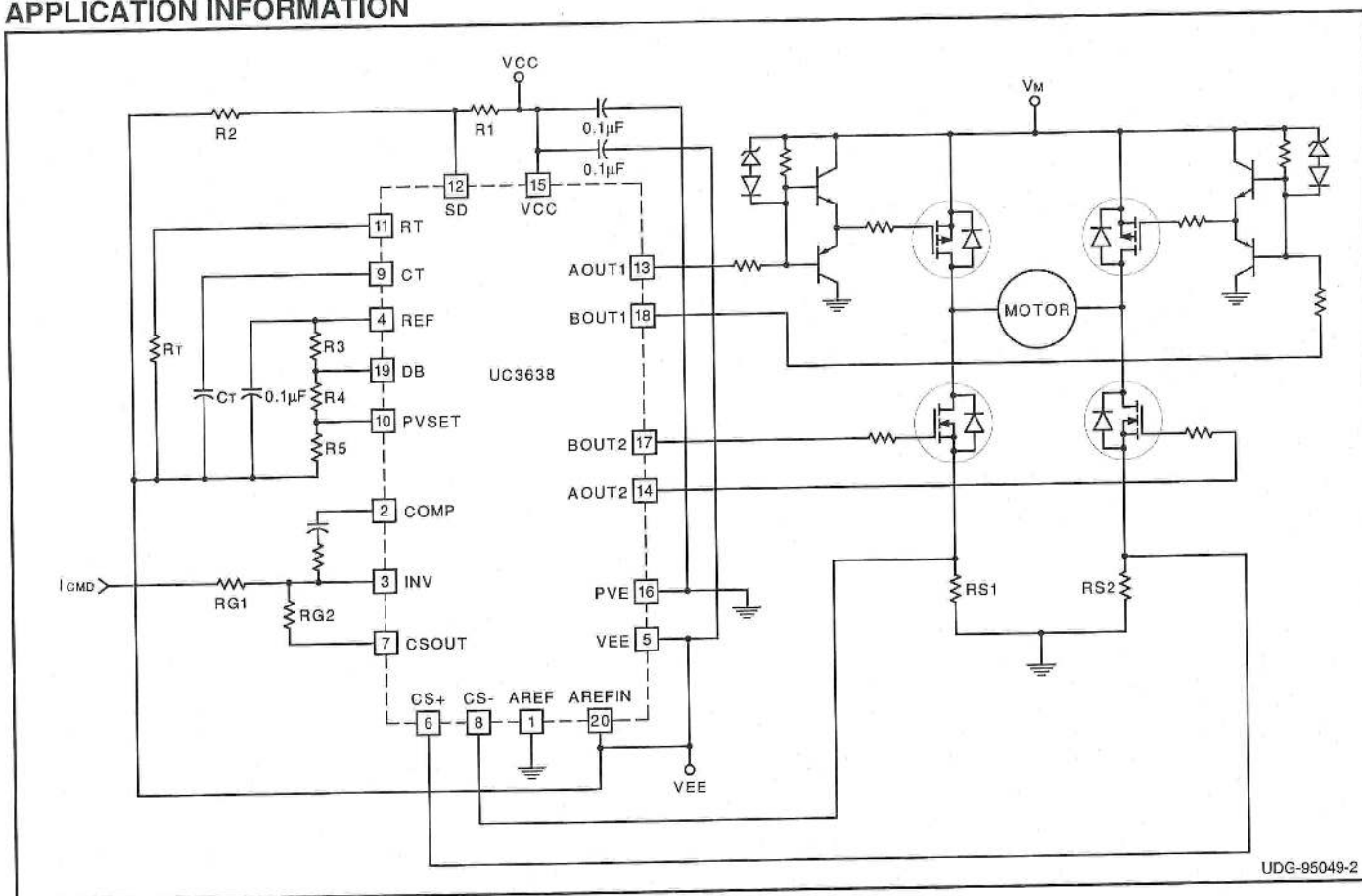

Figure 1. Average Motor Current Control Loop

The UC3638 is designed to provide pulse width modulation control of DC brush motors in applications requiring precision torque, velocity, or position control. Due to its high frequency capability, other high power applications such as switch mode audio amplifiers can also be addressed. Through a combination of circuit sophistication and integration, the designer can maintain a high level of flexibility, while reducing cost compared to solutions using other PWM ICs.

Figure 1 shows a typical application circuit for the UC3638. By taking advantage of the UC3638's many integrated functions, a low cost and compact average current mode motor controller can be designed. Depending on the level of complexity, as many as 15 discrete components and an additional high bandwidth amplifier can be saved compared to a similar circuit using the UC3637 PWM controller.

Oscillator Section and Modulation Scheme

Figure 2 depicts the UC3638 oscillator and PWM waveforms for the condition where the output of the voltage amplifier (COMP) is at the null point (same voltage as AREF). For applications using split voltage supply rails, AREF will normally be tied to system ground. This re-

sults in a voltage null point of zero volts. For this condition, AREFIN should be tied to the negative voltage supply rail (VEE), which disables the internal voltage buffer, allowing AREF to be tied to ground. For a single supply system, AREFIN should be left open circuit, and AREF should be decoupled to VEE (system ground) with at least $0.1\mu\text{F}$. The resulting voltage null point for this case

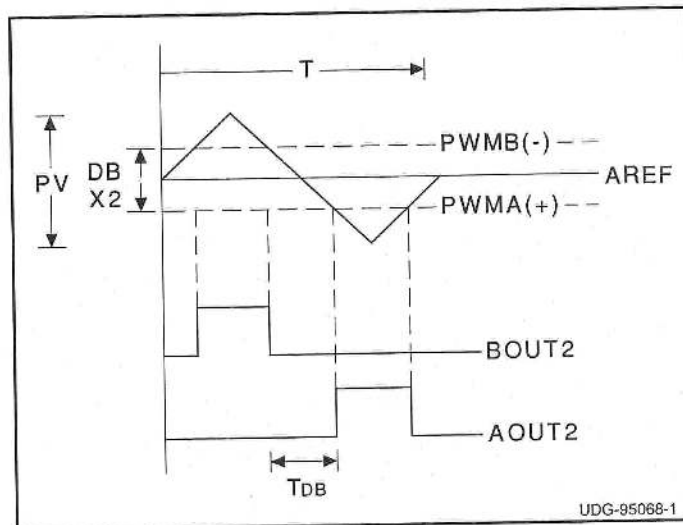

Figure 2. Oscillator and PWM Waveforms

APPLICATION INFORMATION (cont.)

will be half way between ground and VCC, and will automatically track changes in VCC. For cases where a different null point is desired, AREF can be tied to any voltage between VEE + 2V and VCC - 2V. Of course the user must also allow sufficient headroom for the triangle waveform.

Once the system null point has been chosen, the triangle wave amplitude and PWM deadband must be programmed. The amplitude of the triangle wave is determined by trading off noise immunity and gain requirements. In general, the larger the triangle wave amplitude, the greater the immunity to premature termination of PWM pulses due to switching noise. However, high amplitude triangle waves require a greater voltage swing at the output of the voltage amplifier which ultimately reduces forward loop gain.

Programming the PWM deadband allows the user to trade off gain linearity requirements with power amplifier efficiency. If the modulator is configured as in Figure 1, motor current is alternately pulsed by diagonally opposite drive FETs when the servo loop is at null. By adjusting the deadband, the user can program the offset voltage at the input of the PWM comparators. This offset results in deadtime, or time when neither PWM signal is active.

A minimum amount of deadtime is always recommended to provide cross conduction protection at the power amplifier. Setting the deadtime to this minimum level will provide the maximum motor stiffness or holding torque, at the expense of power losses in the output stage. These losses result from the fact that the power amplifier is always sourcing motor current, even at null. As deadtime is increased, amplifier losses at null become less, at the expense of nonlinearity in the gain function. Eventually, if the deadband voltage is increased to equal the amplitude of the triangle wave, error voltages at the null point will result in no PWM pulsing, or a dead zone. After the triangle waveform amplitude and deadband are selected, the operating frequency is easily set by proper selection of CT and RT.

Referring to Figure 1, if the voltage supply rails are $\pm 15V$, and the desired triangle wave oscillator amplitude is 6V p-p, PVSET is set by:

$$V_{PK} - V_{VLY} = 5 \cdot V_{PVSET}$$

$$V_{PVSET} = \frac{6}{5} = 1.2V$$

If 1V of deadband is chosen:

$$5 - V_{DB} = 1V$$

$$V_{DB} = 4V$$

In order to select the programming resistors, a source current for the reference is first selected. For a 1mA source current:

$$R3 + R4 + R5 = \frac{5}{I_{SOURCE}} = \frac{5}{1mA} = 5k$$

$$R3 = \frac{5 - V_{DB}}{I_{SOURCE}} = \frac{1V}{1mA} = 1k$$

$$R4 = \frac{V_{DB} - V_{PVSET}}{I_{SOURCE}} = \frac{4V - 1.2V}{1mA} = 2.8k$$

$$R5 = 5k - 1k - 2.8k = 1.2k$$

All of the voltages described by these equations are referenced to the negative supply rail. In other words, for a split supply system, VREF is actually a negative voltage referenced to ground.

The oscillator frequency is programmed by proper selection of RT and CT. If 220pF is chosen for CT, and an operating frequency of 30kHz is desired, RT is chosen by:

$$F = \frac{1}{5 \cdot RT \cdot CT}$$

$$30kHz = \frac{1}{5 \cdot 220pF \cdot RT}$$

$$RT = 30k$$

With RT = 30k, the charge current out of the RT pin is limited to

$$\frac{1.2V}{30k} = 40\mu A,$$

which is well within the specified maximum of 1mA.

To calculate the actual deadtime or minimum time between PWM pulses (TDB), the ratio of the deadband voltage to the triangle wave amplitude is multiplied by half the oscillator period:

$$T_{DB} = \frac{DB}{V_{PK} - V_{VLY}} \cdot \frac{1}{f}$$

$$= \frac{5 - V_{DB}}{5 \cdot V_{PVSET}} \cdot (5 \cdot RT \cdot CT)$$

$$= \frac{(5 - V_{DB}) \cdot RT \cdot CT}{V_{PVSET}}$$

For this example the deadtime is:

$$T_{DB} = \frac{1 \cdot 30k \cdot 220pF}{1.2} = 5.5\mu sec$$

If voltage feedforward is desired, PVSET should be derived off of the supply rails instead of VREF. This way changes in the supply voltage will linearly regulate the modulator gain, which decreases control loop susceptibility to line voltage variations. Since the voltage on the RT pin is a buffered version of PVSET, charge current tracks oscillator amplitude, and therefore the frequency

APPLICATION INFORMATION (cont.)

remains constant, preventing low frequency oscillator modulation in the presence of line voltage changes.

Output Drivers

The output driver section provides separate output drivers for high and low side drive of both PWM signals. For many applications, the 500mA peak output current capability of the low side drivers (AOUT2 and BOUT2) is sufficient to directly connect to the appropriate low side MOSFETs of the H-bridge. A current limiting gate resistor may be used to control switching time if high levels of dv/dt or di/dt are expected at the drains of the MOSFETs. If more current drive capability is required, the PWM drive signals can be buffered with bipolar transistors.

The open collector high side drivers (AOUT1 and BOUT1) are designed to control high side P-channel MOSFETs. Depending on voltage and speed requirements, the driver stage can be simplified from the one shown on Figure 1. If high side N-channel MOSFETs are desired, a boot strap or charge pump based drive circuit can be used as long as 100% duty cycle operation is not required.

Average Current Control

The UC3638 incorporates all of the necessary features for precise average current loop control of a DC motor. In the circuit shown in Figure 1, motor current is sensed differentially across two current sense resistors. By using two current sense resistors both the current sourced from the motor voltage supply (Vm) and the flyback current are sensed in the correct polarity to provide true torque control. If only one current sensed resistor is used, the flyback current will circulate through the body diodes of the lower MOSFETs and bypass the current sense resistor. The result will be a duty cycle dependent error term in the loop torque control function. In order to prevent high frequency spikes from contributing excessive error to the current control loop, the switching speed of the MOSFETs must be controlled so that significant transient current spikes do not couple across the drain to source capacitance of the MOSFETs.

The X5 current amplifier multiplies the current signal by a factor of 5 and feeds the average current signal into the error amplifier. A window comparator detects if the peak current signal at the output of the current amplifier has a magnitude greater than 2.5V in either polarity and provides pulse-by-pulse peak current limiting. The loop should be designed so that peak motor current never reaches this level during normal operation.

With integral compensation, the average current loop will have very high DC gain, resulting in effectively no average DC motor current error. For stability purposes, the high frequency gain of the voltage error amplifier must be designed such that magnitude of the slope of the error amplifier output (COMP) must be less than or equal to the magnitude of the slope of the triangle waveform.

If RS1 = RS2 = RS, the DC gain of the current control loop can be calculated as:

$$\frac{I_{MOTOR}}{I_{CMD}} = \frac{RG2}{5 \cdot RS}$$

If the UC3638 is set up in a simple velocity or position control loop, the feedback voltage (speed or position) is summed directly into the voltage error amplifier, and the current sense amplifier is only used for peak current limit control. The motor can also be replaced by another high power device, such as an audio speaker, and the same type of amplifier can be used. In the case of audio however, a higher switching frequency will probably be desired to prevent switching noise from infiltrating the audio frequency range.

UVLO and Shutdown

The UC3638 contains undervoltage lockout (UVLO) circuitry to prevent unwanted bridge turn-on before sufficient supply voltage is available. The open collector drivers (AOUT1 and BOUT1) are held off (no sink current) and the totem pole drivers (AOUT 2 and BOUT2) are pulled low until the voltage between VCC and VEE reaches 9V typical. The UVLO circuitry becomes active at approximately 1V, and before this level the totem pole drivers are held low with passive pull down resistors.

The shutdown pin holds the output drivers in their inactive state unless it is pulled 2.5V below VCC. An open collector gate or transistor can be used as an external enable signal, or a turn-on voltage higher than UVLO can be programmed with a resistive divider. In the case of Figure 1, the turn on voltage VSTART can be calculated as:

$$V_{START} = \frac{2.5 \cdot (R1 + R2)}{R1}$$

If a delayed start is desired, a capacitor can be placed in parallel with R1 to slow down the change in voltage at the shutdown pin, and thus provide a user programmable startup time.

PACKAGING INFORMATION

Orderable Device	Status (1)	Package Type	Package Drawing	Pins	Package Qty	Eco Plan (2)	Lead/Ball Finish (6)	MSL Peak Temp (3)	Op Temp (°C)	Device Marking (4/5)	Samples
UC2638DW	NRND	SOIC	DW	20	25	Green (RoHS & no Sb/Br)	CU NIPDAU	Level-2-260C-1 YEAR	-40 to 85	UC2638DW	
UC2638DWG4	NRND	SOIC	DW	20	25	Green (RoHS & no Sb/Br)	CU NIPDAU	Level-2-260C-1 YEAR	-40 to 85	UC2638DW	
UC2638DWTR	NRND	SOIC	DW	20		TBD	Call TI	Call TI	-40 to 85	UC2638DW	
UC2638N	NRND	PDIP	N	20	20	Green (RoHS & no Sb/Br)	CU NIPDAU	N / A for Pkg Type	-40 to 85	UC2638N	
UC2638NG4	NRND	PDIP	N	20	20	Green (RoHS & no Sb/Br)	CU NIPDAU	N / A for Pkg Type	-40 to 85	UC2638N	
UC3638DW	ACTIVE	SOIC	DW	20	25	Green (RoHS & no Sb/Br)	CU NIPDAU	Level-2-260C-1 YEAR	0 to 70	UC3638DW	Samples
UC3638DWG4	ACTIVE	SOIC	DW	20	25	Green (RoHS & no Sb/Br)	CU NIPDAU	Level-2-260C-1 YEAR	0 to 70	UC3638DW	Samples
UC3638DWTR	ACTIVE	SOIC	DW	20	2000	Green (RoHS & no Sb/Br)	CU NIPDAU	Level-2-260C-1 YEAR	0 to 70	UC3638DW	Samples
UC3638N	ACTIVE	PDIP	N	20	20	Green (RoHS & no Sb/Br)	CU NIPDAU	N / A for Pkg Type	0 to 70	UC3638N	Samples
UC3638NG4	ACTIVE	PDIP	N	20	20	Green (RoHS & no Sb/Br)	CU NIPDAU	N / A for Pkg Type	0 to 70	UC3638N	Samples

(1) The marketing status values are defined as follows:

ACTIVE: Product device recommended for new designs.

LIFEBUY: TI has announced that the device will be discontinued, and a lifetime-buy period is in effect.

NRND: Not recommended for new designs. Device is in production to support existing customers, but TI does not recommend using this part in a new design.

PREVIEW: Device has been announced but is not in production. Samples may or may not be available.

OBSELETE: TI has discontinued the production of the device.

(2) Eco Plan - The planned eco-friendly classification: Pb-Free (RoHS), Pb-Free (RoHS Exempt), or Green (RoHS & no Sb/Br) - please check <http://www.ti.com/productcontent> for the latest availability information and additional product content details.

TBD: The Pb-Free/Green conversion plan has not been defined.

Pb-Free (RoHS): TI's terms "Lead-Free" or "Pb-Free" mean semiconductor products that are compatible with the current RoHS requirements for all 6 substances, including the requirement that lead not exceed 0.1% by weight in homogeneous materials. Where designed to be soldered at high temperatures, TI Pb-Free products are suitable for use in specified lead-free processes.

Pb-Free (RoHS Exempt): This component has a RoHS exemption for either 1) lead-based flip-chip solder bumps used between the die and package, or 2) lead-based die adhesive used between the die and leadframe. The component is otherwise considered Pb-Free (RoHS compatible) as defined above.

Green (RoHS & no Sb/Br): TI defines "Green" to mean Pb-Free (RoHS compatible), and free of Bromine (Br) and Antimony (Sb) based flame retardants (Br or Sb do not exceed 0.1% by weight in homogeneous material)

- (3) MSL, Peak Temp. - The Moisture Sensitivity Level rating according to the JEDEC industry standard classifications, and peak solder temperature.
- (4) There may be additional marking, which relates to the logo, the lot trace code information, or the environmental category on the device.
- (5) Multiple Device Markings will be inside parentheses. Only one Device Marking contained in parentheses and separated by a "~" will appear on a device. If a line is indented then it is a continuation of the previous line and the two combined represent the entire Device Marking for that device.
- (6) Lead/Ball Finish - Orderable Devices may have multiple material finish options. Finish options are separated by a vertical ruled line. Lead/Ball Finish values may wrap to two lines if the finish value exceeds the maximum column width.

Important Information and Disclaimer:The information provided on this page represents TI's knowledge and belief as of the date that it is provided. TI bases its knowledge and belief on information provided by third parties, and makes no representation or warranty as to the accuracy of such information. Efforts are underway to better integrate information from third parties. TI has taken and continues to take reasonable steps to provide representative and accurate information but may not have conducted destructive testing or chemical analysis on incoming materials and chemicals. TI and TI suppliers consider certain information to be proprietary, and thus CAS numbers and other limited information may not be available for release.

In no event shall TI's liability arising out of such information exceed the total purchase price of the TI part(s) at issue in this document sold by TI to Customer on an annual basis.

OTHER QUALIFIED VERSIONS OF UC3638 :

- Military: [UC1638](#)

NOTE: Qualified Version Definitions:

- Military - QML certified for Military and Defense Applications

TAPE AND REEL INFORMATION



QUADRANT ASSIGNMENTS FOR PIN 1 ORIENTATION IN TAPE



*All dimensions are nominal

Device	Package Type	Package Drawing	Pins	SPQ	Reel Diameter (mm)	Reel Width W1 (mm)	A0 (mm)	B0 (mm)	K0 (mm)	P1 (mm)	W (mm)	Pin1 Quadrant
UC3638DWTR	SOIC	DW	20	2000	330.0	24.4	10.8	13.3	2.7	12.0	24.0	Q1

TAPE AND REEL BOX DIMENSIONS



*All dimensions are nominal

Device	Package Type	Package Drawing	Pins	SPQ	Length (mm)	Width (mm)	Height (mm)
UC3638DWTR	SOIC	DW	20	2000	367.0	367.0	45.0

N (R-PDIP-T**)

PLASTIC DUAL-IN-LINE PACKAGE

16 PINS SHOWN



- NOTES:
- A. All linear dimensions are in inches (millimeters).
 - B. This drawing is subject to change without notice.
 - Falls within JEDEC MS-001, except 18 and 20 pin minimum body length (Dim A).
 - The 20 pin end lead shoulder width is a vendor option, either half or full width.

DW0020A



PACKAGE OUTLINE

SOIC - 2.65 mm max height

SOIC



4220724/A 05/2016

NOTES:

1. All linear dimensions are in millimeters. Dimensions in parenthesis are for reference only. Dimensioning and tolerancing per ASME Y14.5M.
2. This drawing is subject to change without notice.
3. This dimension does not include mold flash, protrusions, or gate burrs. Mold flash, protrusions, or gate burrs shall not exceed 0.15 mm per side.
4. This dimension does not include interlead flash. Interlead flash shall not exceed 0.43 mm per side.
5. Reference JEDEC registration MS-013.

EXAMPLE BOARD LAYOUT

DW0020A

SOIC - 2.65 mm max height

SOIC



LAND PATTERN EXAMPLE
SCALE:6X

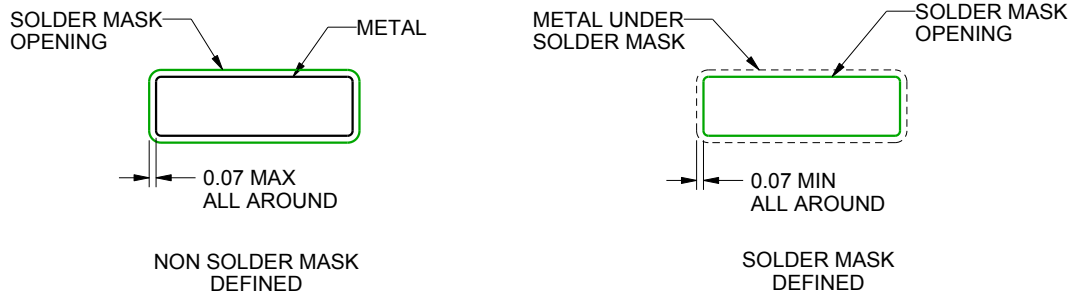

SOLDER MASK DETAILS

4220724/A 05/2016

NOTES: (continued)

- 6. Publication IPC-7351 may have alternate designs.
- 7. Solder mask tolerances between and around signal pads can vary based on board fabrication site.

EXAMPLE STENCIL DESIGN

DW0020A

SOIC - 2.65 mm max height

SOIC

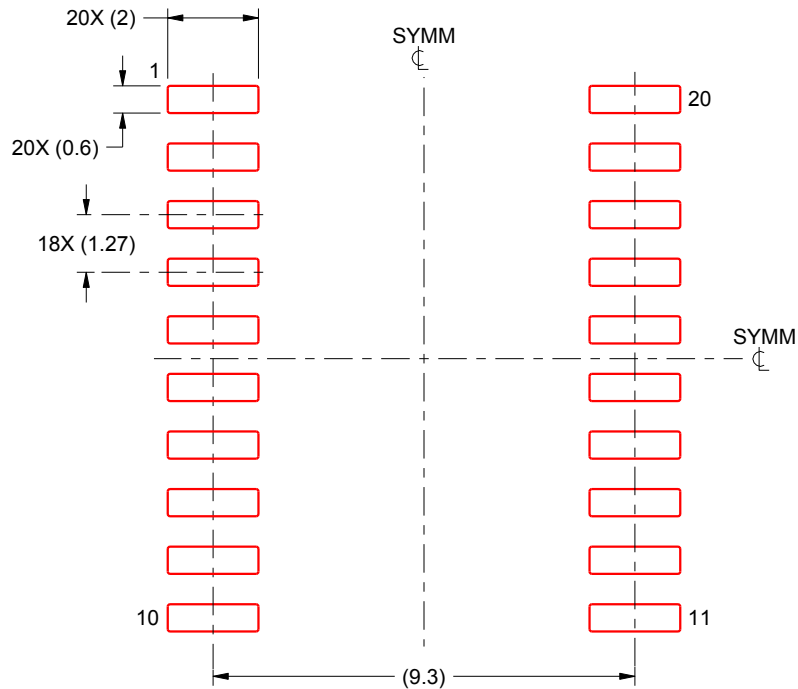

SOLDER PASTE EXAMPLE
BASED ON 0.125 mm THICK STENCIL
SCALE:6X

4220724/A 05/2016

NOTES: (continued)

8. Laser cutting apertures with trapezoidal walls and rounded corners may offer better paste release. IPC-7525 may have alternate design recommendations.
9. Board assembly site may have different recommendations for stencil design.

IMPORTANT NOTICE

Texas Instruments Incorporated and its subsidiaries (TI) reserve the right to make corrections, enhancements, improvements and other changes to its semiconductor products and services per JESD46, latest issue, and to discontinue any product or service per JESD48, latest issue. Buyers should obtain the latest relevant information before placing orders and should verify that such information is current and complete. All semiconductor products (also referred to herein as "components") are sold subject to TI's terms and conditions of sale supplied at the time of order acknowledgment.

TI warrants performance of its components to the specifications applicable at the time of sale, in accordance with the warranty in TI's terms and conditions of sale of semiconductor products. Testing and other quality control techniques are used to the extent TI deems necessary to support this warranty. Except where mandated by applicable law, testing of all parameters of each component is not necessarily performed.

TI assumes no liability for applications assistance or the design of Buyers' products. Buyers are responsible for their products and applications using TI components. To minimize the risks associated with Buyers' products and applications, Buyers should provide adequate design and operating safeguards.

TI does not warrant or represent that any license, either express or implied, is granted under any patent right, copyright, mask work right, or other intellectual property right relating to any combination, machine, or process in which TI components or services are used. Information published by TI regarding third-party products or services does not constitute a license to use such products or services or a warranty or endorsement thereof. Use of such information may require a license from a third party under the patents or other intellectual property of the third party, or a license from TI under the patents or other intellectual property of TI.

Reproduction of significant portions of TI information in TI data books or data sheets is permissible only if reproduction is without alteration and is accompanied by all associated warranties, conditions, limitations, and notices. TI is not responsible or liable for such altered documentation. Information of third parties may be subject to additional restrictions.

Resale of TI components or services with statements different from or beyond the parameters stated by TI for that component or service voids all express and any implied warranties for the associated TI component or service and is an unfair and deceptive business practice. TI is not responsible or liable for any such statements.

Buyer acknowledges and agrees that it is solely responsible for compliance with all legal, regulatory and safety-related requirements concerning its products, and any use of TI components in its applications, notwithstanding any applications-related information or support that may be provided by TI. Buyer represents and agrees that it has all the necessary expertise to create and implement safeguards which anticipate dangerous consequences of failures, monitor failures and their consequences, lessen the likelihood of failures that might cause harm and take appropriate remedial actions. Buyer will fully indemnify TI and its representatives against any damages arising out of the use of any TI components in safety-critical applications.

In some cases, TI components may be promoted specifically to facilitate safety-related applications. With such components, TI's goal is to help enable customers to design and create their own end-product solutions that meet applicable functional safety standards and requirements. Nonetheless, such components are subject to these terms.

No TI components are authorized for use in FDA Class III (or similar life-critical medical equipment) unless authorized officers of the parties have executed a special agreement specifically governing such use.

Only those TI components which TI has specifically designated as military grade or "enhanced plastic" are designed and intended for use in military/aerospace applications or environments. Buyer acknowledges and agrees that any military or aerospace use of TI components which have **not** been so designated is solely at the Buyer's risk, and that Buyer is solely responsible for compliance with all legal and regulatory requirements in connection with such use.

TI has specifically designated certain components as meeting ISO/TS16949 requirements, mainly for automotive use. In any case of use of non-designated products, TI will not be responsible for any failure to meet ISO/TS16949.

Products

Audio	www.ti.com/audio
Amplifiers	amplifier.ti.com
Data Converters	dataconverter.ti.com
DLP® Products	www.dlp.com
DSP	dsp.ti.com
Clocks and Timers	www.ti.com/clocks
Interface	interface.ti.com
Logic	logic.ti.com
Power Mgmt	power.ti.com
Microcontrollers	microcontroller.ti.com
RFID	www.ti-rfid.com
OMAP Applications Processors	www.ti.com/omap
Wireless Connectivity	www.ti.com/wirelessconnectivity

Applications

Automotive and Transportation	www.ti.com/automotive
Communications and Telecom	www.ti.com/communications
Computers and Peripherals	www.ti.com/computers
Consumer Electronics	www.ti.com/consumer-apps
Energy and Lighting	www.ti.com/energy
Industrial	www.ti.com/industrial
Medical	www.ti.com/medical
Security	www.ti.com/security
Space, Avionics and Defense	www.ti.com/space-avionics-defense
Video and Imaging	www.ti.com/video

TI E2E Community

e2e.ti.com