

LOC	DIST	P	F	ZONE	LTR	DESCRIPTION	DATE	APPD
AD	39				H	REV PER 0010-1061-94	12-28-96	JH
					J	REV PER 0010-1175-95	12-28-96	JH

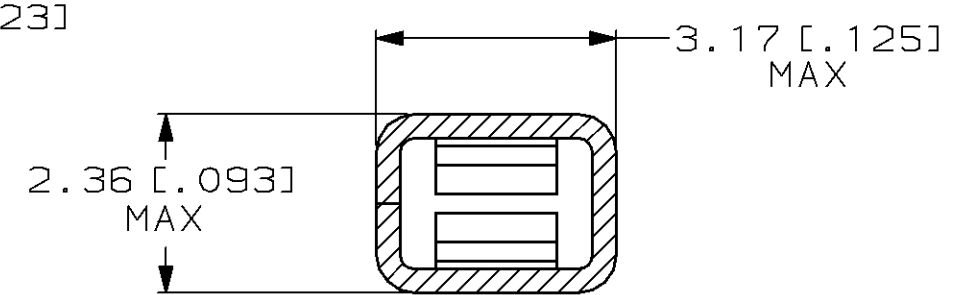
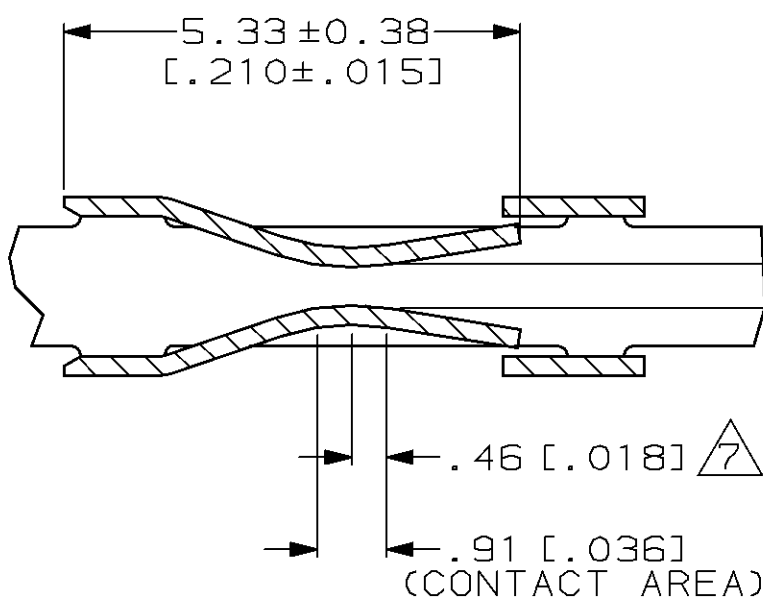
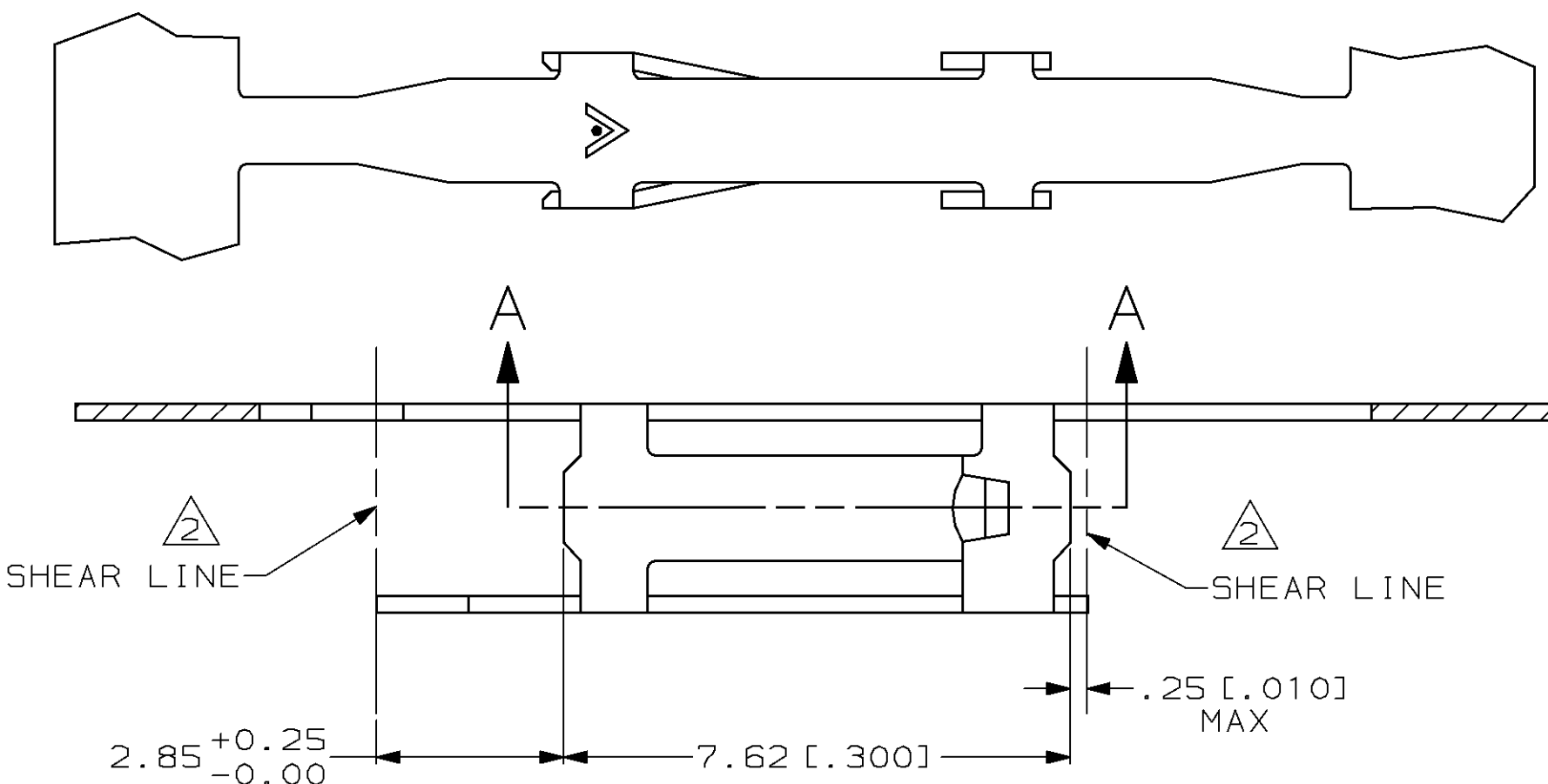

SECTION A-A

SECTION B-B

- 1 PHOSPHOR BRONZE 0.25[.010] COML.
- 2 SHEAR LINES DEFINE LOOSE PIECE PART.
- 3 PRE-TINNED 0.00076[.000030] MIN THICK.
- 4 GOLD FLASH OVER 0.00127[.000050] NICKEL ENTIRE CONTACT, 0.00076[.000030] GOLD ON CONTACT AREA.
- 5 0.00038[.000015] GOLD ON CONTACT AREA, 0.00254-0.00508[.000100-.000200] BRIGHT TIN-LEAD ON TERMINATION AREA, ALL OVER 0.00127[.000050] NICKEL.
- 6 0.00076[.000030] GOLD ON CONTACT AREA, 0.00254-0.00508[.000100-.000200] BRIGHT TIN-LEAD ON TERMINATION AREA, ALL OVER 0.00127[.000050] NICKEL.
- 7 POINT OF MEASUREMENT FOR PLATING THICKNESS.
- 8 "H" RECEPTACLE CENTERS MAY VARY DEPENDING ON REQUIREMENTS. MINIMUM NOMINAL CENTERLINE SPACING BETWEEN ADJACENT RECEPTACLES IS 3.18[.125].

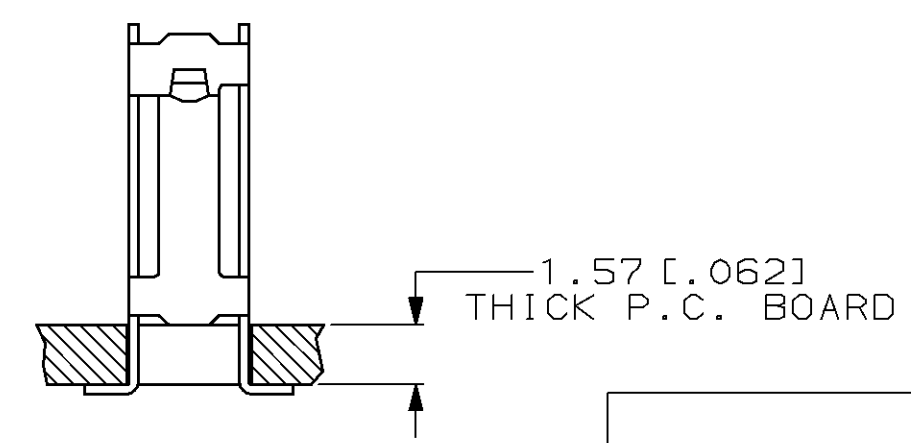
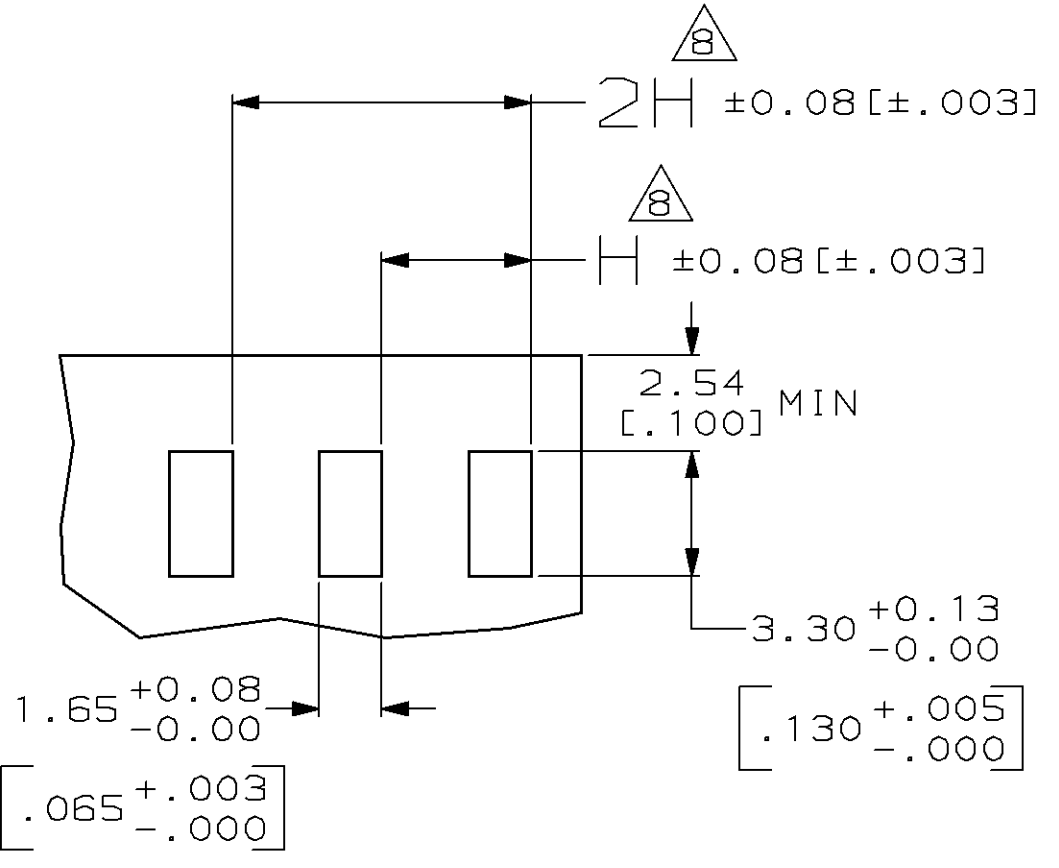
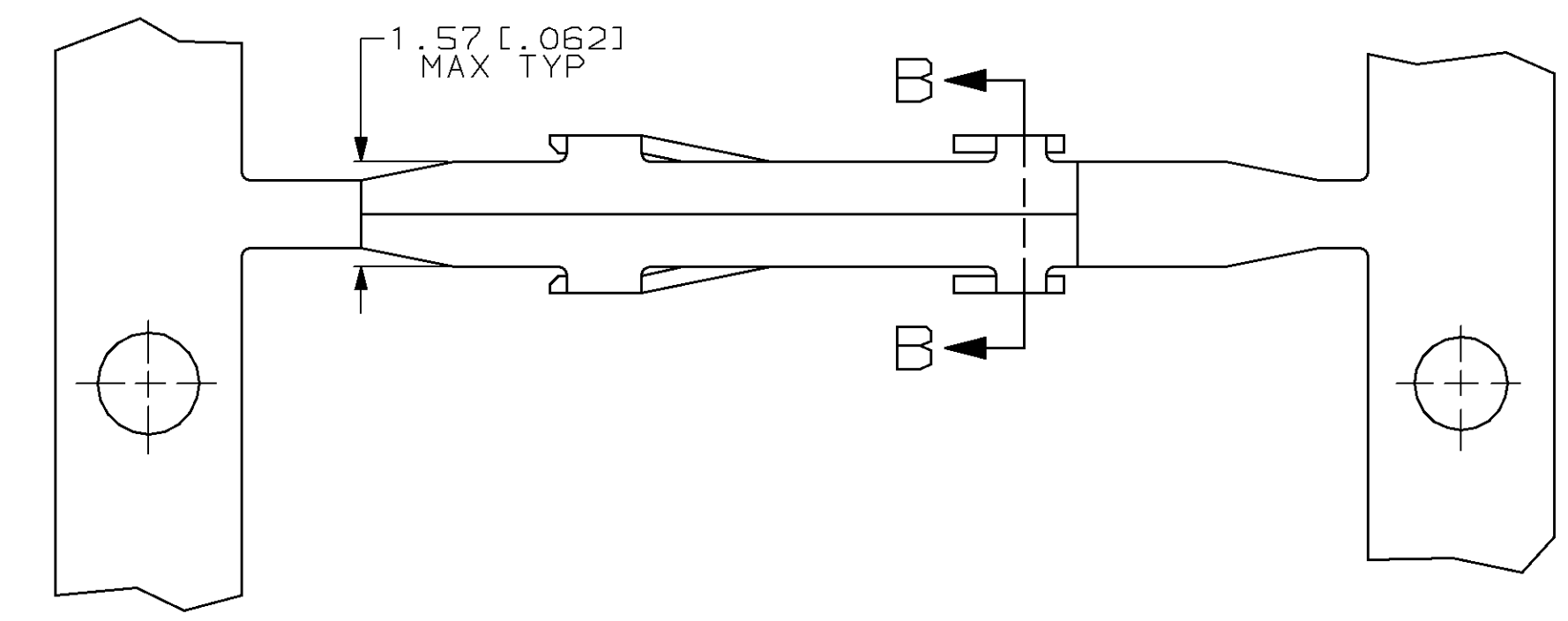

TYPICAL APPLICATION

OBSOLETE	86443-6	6	1	86442-6
OBSOLETE	86443-3	5	1	86442-4
OBSOLETE	86443-2	4	1	86442-2
	86443-1	3	1	86442-1
	LOOSE PIECE PART NO.	FINISH	MATERIAL	PART NUMBER

		PART NO	
DO NOT SCALE PRINT. UNLESS SPECIFIED DIMENSIONS IN mm [INCHES] TOLERANCES ON:	DR 28-DEC-96 E. BRANDBERG	AMP Incorporated Harrisburg, PA 17105-3608	
2 PLC DEC ± -	CHK 28-DEC-96 J. HERRINGTON		
3 PLC DEC ± 0.13[.005]	APPD 28-DEC-96 J. HERRINGTON	NAME	
ANGLES ± -	APPD 28-DEC-96 D. TROUT	FEMALE CONTACT - VERTICAL TYPE "A", MOD 1, HIGH PRESSURE	
MATERIAL	PRODUCT SPEC	SIZE	CAGE CODE
SEE TABLE	-	C	00779
FINISH	APPLICATION SPEC	DRAWING NO	
SEE TABLE	-	C=86442	
WEIGHT	-	SCALE 10:1	SHEET 1 OF 1

THIS DRAWING IS A CONTROLLED DOCUMENT FOR AMP INCORPORATED. IT IS SUBJECT TO CHANGE AND THE CONTROLLING ENGINEERING ORGANIZATION SHOULD BE CONTACTED FOR THE LATEST REVISION.