

Built-in antenna IEEE802.11b/g/n (1x1) Wireless LAN Module BP3595

HARDWARE SPECIFICATION

Version 1.0.0



Revision history

Ver.	Contents	Date
1.0.0	First edition	15/8/20



1 ABSTRACT

This is specification for the wireless LAN module built-in wireless LAN LSI BU1805GU and antenna based on IEEE802.11b/g/n (1x1) made by ROHM.

2 CONTENTS

1	ABSTRACT	3
2	CONTENTS	4
3	ABSOLUTE MAXIMUM RATINGS	5
4	RECOMMENDED OPERATING CONDITIONS.....	6
5	MAIN CHARACTERISTICS	7
6	BLOCK DIAGRAM.....	8
7	ELECTRICAL CHARACTERISTICS.....	9
8	TERMINAL FUNCTIONS.....	10
9	DIMENSIONS	13
10	PRECAUTIONS FOR MOUNTING	14
11	ABOUT THE FIXATION OF THE MODULE	15
12	PRODUCT LABEL SPEC	16
13	REFERENCE CIRCUIT.....	17
14	PRECAUTIONS AS RESET OPERATION.....	22
15	OPERATING	23
16	PRECAUTIONS AS A WIRELESS EQUIPMENT (1)	24
17	PRECAUTIONS AS A WIRELESS EQUIPMENT (2)	25

3 ABSOLUTE MAXIMUM RATINGS

No.	PARAMETER	SYMBOL	LIMITS	UNIT	REMARKS
1	Power supply voltage	VCC	-0.3 ~ +3.6	V	DC
2	Operating temperature range	Topr	-40 ~ 85	°C	-
3	Storage temperature range	Tstg	-40 ~ 85	°C	-

Note) Absolute maximum ratings are the values that must not be exceeded at any time under any application or any test conditions. Please make design keeping enough margins accordingly.

4 RECOMMENDED OPERATING CONDITIONS

No.	PARAMETER	SYMBOL	SPEC			UNIT	REMARKS
			MIN.	TYP.	MAX.		
1	Power supply voltage	VCC	3.1	3.3	3.5	V	-
2	Operating temperature range	Ta	-40	25	85	°C	-

5 MAIN CHARACTERISTICS

No.	PARAMETER	CHARACTERISTICS
1	Frequency width	2,400MHz ~ 2,483.5 MHz (ch1~ch13)
2	Frequency tolerance	WITHIN ± 25 ppm
3	RF output power (*1)	IEEE802.11b : 15dBm \pm 2dB IEEE802.11g : 13dBm \pm 2dB IEEE802.11n : 12dBm \pm 2dB
4	Supported data rates	IEEE802.11b : 1 ~ 11Mbps IEEE802.11g : 6 ~ 54Mbps IEEE802.11n : 6.5 ~ 72.2Mbps
5	Receiving sensitivity (*1)	IEEE802.11b : -94dBm @1Mbps, -89dBm @11Mbps IEEE802.11g : -92dBm @6Mbps, -73dBm @54Mbps IEEE802.11n : -90dBm @6.5Mbps, -68dBm @72.2Mbps
6	Security function	64bit/128bit WEP, TKIP, AES (*2)
7	Host Interface	USB2.0 (High-Speed mode) SDIO Ver.2.00 (High-Speed mode) UART (~921600bps)
8	Power supply voltage	3.3V only

(*1) RF output power and receiving sensitivity are performance value that is at the electricity supplying point for antenna in the below figure.

(*2) 64bit/128bit WEP, TKIP, and AES are everything processed with hardware.

6 BLOCK DIAGRAM

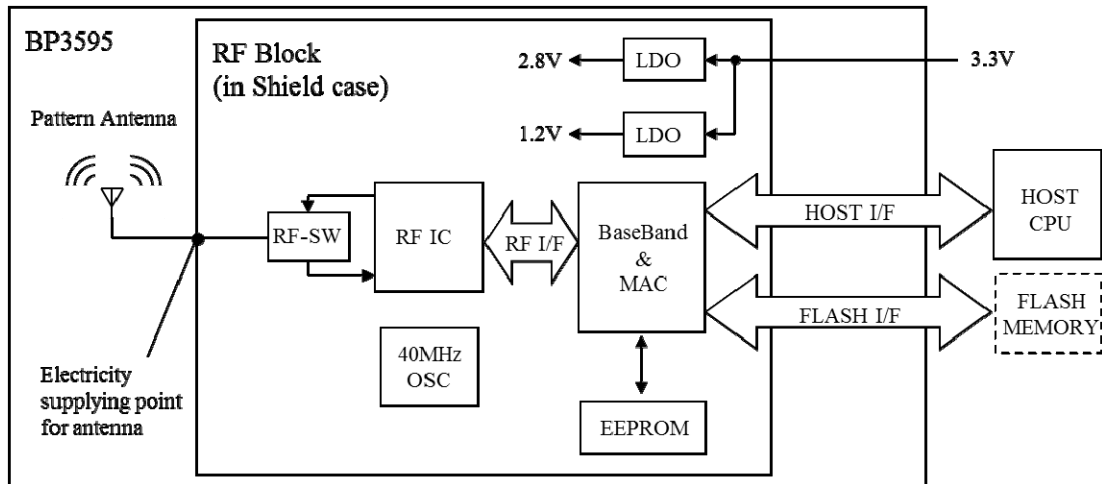

Fig 1. Block diagram

- A Flash memory (option) is necessary for use the flash boot function.

7 ELECTRICAL CHARACTERISTICS

CONDITIONS : Ta=25°C, VCC=3.3V, GND=0.0V

No.	PARAMETER	CONDITION	SPEC			UNIT	REMARKS
			MIN.	TYP.	MAX.		
1	Consumption current	Sending	240	300	360	mA	Continuous
			280	340	400	mA	Continuous (With USB)
		Receiving	160	200	240	mA	-
			200	240	280	mA	With USB
	Sleep mode	-	1	-	mA	-	
2	Center frequency	-	2412	-	2472	MHz	-
3	Frequency deviation	-	-25	-	25	ppm	-
4	RF output power	11b : 11Mbps	13	15	17	dBm	(*1)
		11g : 54Mbps	11	13	15	dBm	(*1)
		11n : MCS7	10	12	14	dBm	(*1)
5	Unnecessary out-of-band radiation	-	-	-	2.5	uW/MHz	-
6	Transmit spectrum mask	DSSS	-	-	-30	dBr	1 st Side-lobe
		11Mbps	-	-	-50	dBr	2 nd Side-lobe
		OFDM 54Mbps	-	-	-20	dBr	±11MHz
			-	-	-28	dBr	±20MHz
			-	-	-40	dBr	±30MHz
7	Receiving sensitivity	11b : 11Mbps	-	-89	-76	dBm	PER<8% (*1)
		11g : 54Mbps	-	-73	-65	dBm	PER<10% (*1)
		11n : MCS7	-	-68	-64	dBm	PER<10% (*1)
8	Unnecessary radiation for receiving	Fr<1GHz	-	-	4	nW	-
		Fr≥1GHz	-	-	20	nW	-

(*1) At electricity supplying point for antenna.

8 TERMINAL FUNCTIONS

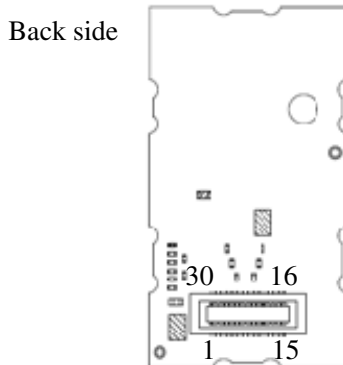

BP3595 Connector (Receptacle) Type

: DF40C-30DS-0.4V(51) (Hirose electric Co., Ltd.)

User-side Connector (Plug) Type

: DF40C-30DP-0.4V(51) (Hirose electric Co., Ltd.)

Table 1. Module Terminal Functions (1/2)

No.	TERMINAL NAME	I/O	FUNCTIONS	REMARKS
1	BOOT_SEL0	I(*)	Boot mode select	(**)
2	GPIO8/32k	I/O	General purpose Input/Output 8	GPIO 8 or 32.768kHz clock input
3	GPIO6	I/O	General purpose Input/Output 6	-
4	GPIO0	I/O	General purpose Input/Output 0	-
5	V28_STBY	I	V28 LDO Standby port	Active Hi (VCC Voltage)
6	GPIO2	I/O	General purpose Input/Output 2	-
7	GPIO1	I/O	General purpose Input/Output 1	-
8	V12_STBY	I	V12 LDO Standby port	Active Hi (VCC Voltage)
9	UART_TXD	O	UART sending data	-
10	UART_RXD	I	UART receiving data	-
11	FLASH_TXD	I/O	Flash memory sending data	Terminal for flash boot
12	FLASH_CLK	O	Flash memory clock	Terminal for flash boot
13	FLASH_CSB	O	Flash memory chip select	Terminal for flash boot
14	FLASH_RXD	I	Flash memory receiving data	Terminal for flash boot
15	PRST	I	Power on reset	0:Reset, 1:Normal

Table 1. Module Terminal Functions (2/2)

No.	TERMINAL NAME	I/O	FUNCTIONS	REMARKS
16	GND	-	Ground	-
17	USB_DM	AI/O	USB data minus	-
18	USB_DP	AI/O	USB data plus	-
19	GND	-	Ground	-
20	SDDATA2	I/O	SDIO data 2	-
21	SDDATA3	I/O	SDIO data 3	-
22	SDCMD	I/O	SDIO command	-
23	VCC	-	Power supply 3.3V	Module power supply input
24	VCC	-	Power supply 3.3V	Module power supply input
25	SDCLK	I	SDIO clock	-
26	SDDATA0	I/O	SDIO data 0	-
27	SDDATA1	I/O	SDIO data 1	-
28	HOST_SEL	I(*)	Host I/F select	0:USB, 1:SDIO
29	FLASH_SEL	I(*)	Flash memory area select	0:region1, 1:region2
30	BOOT_SEL1	I(*)	Boot mode select	(**)

(*) FLASH_SEL / HOST_SEL / BOOT_SEL0 / BOOT_SEL1 terminals hold the value after reset (Power On Reset). After reset, these terminals are used for another purpose in the module. These terminals have pull down resistance inside. Therefore, please set these terminals OPEN in case of setting for “0” and Pull up 3.3V (power supply voltage) with 3kΩ ~ 5kΩ resistor (recommendation is 4.7kΩ resistor) in case of setting for “1”.

When the host MCU controls these terminal, please do not connect directly with output terminal of host MCU and insert 3kΩ ~ 5kΩ resistor (recommendation is 4.7kΩ resistor) between them. When FLASH BOOT function is not used, FLASH_TXD terminal (pin 11) should be connected pull down resistor of 47kΩ.

When FLASH BOOT function is used, FLASH_TXD terminal (pin 11) and FLASH_RXD (pin 14) terminal would be connected pull down resistor, if you need.

PRST is POWER ON RESET terminal. It is connected 4.7kΩ resistor + 2.2uF capacitor at 3.3V inside the module.

In case that need to watch the power supply voltage, please connect such as OPEN DRAIN RESET IC for this terminal.



V12_STBY terminal and V28_STBY terminal control LDO which are mounted BP3595.

Hi(VCC voltage): active, Lo(GND):stand-by

Please open the other unused terminal.

(**) BOOT_SEL terminal select boot location of firmware.

BOOT_SEL[1:0]

00:USB, 01:SDIO, 10:FLASH, 11:UART

9 DIMENSIONS

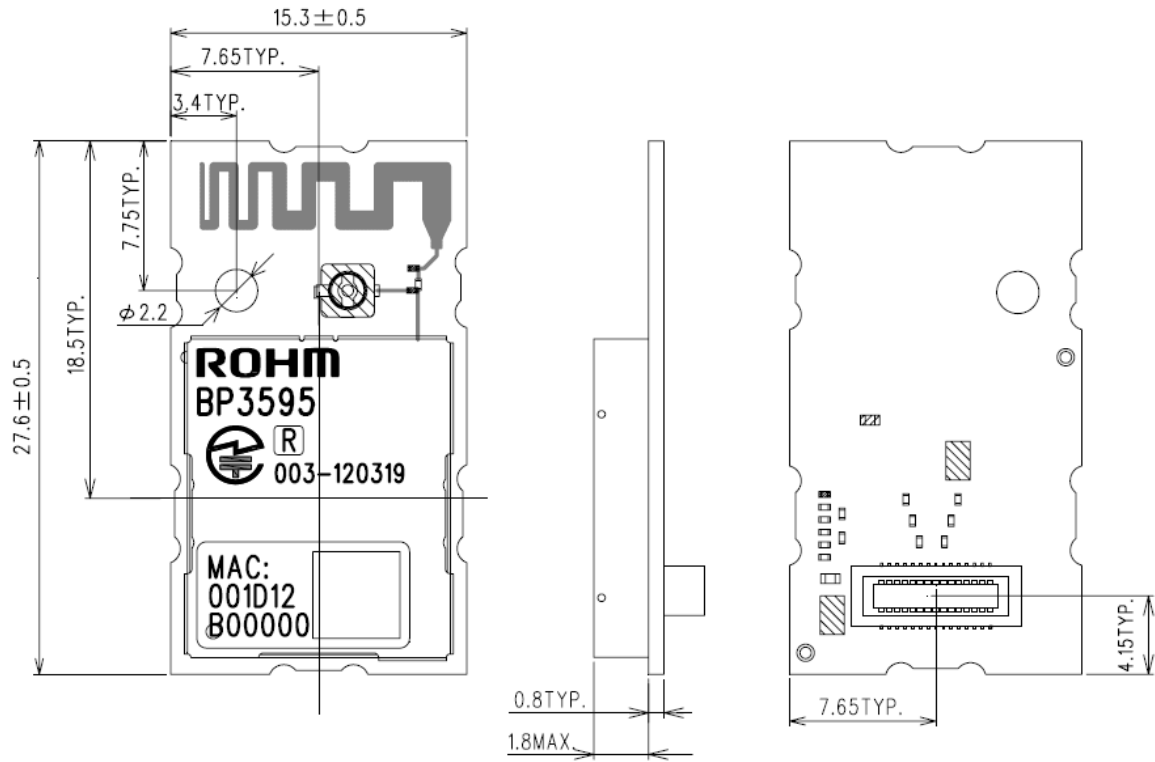

Fig.2 Dimensions (Unit: mm)

10 PRECAUTIONS FOR MOUNTING

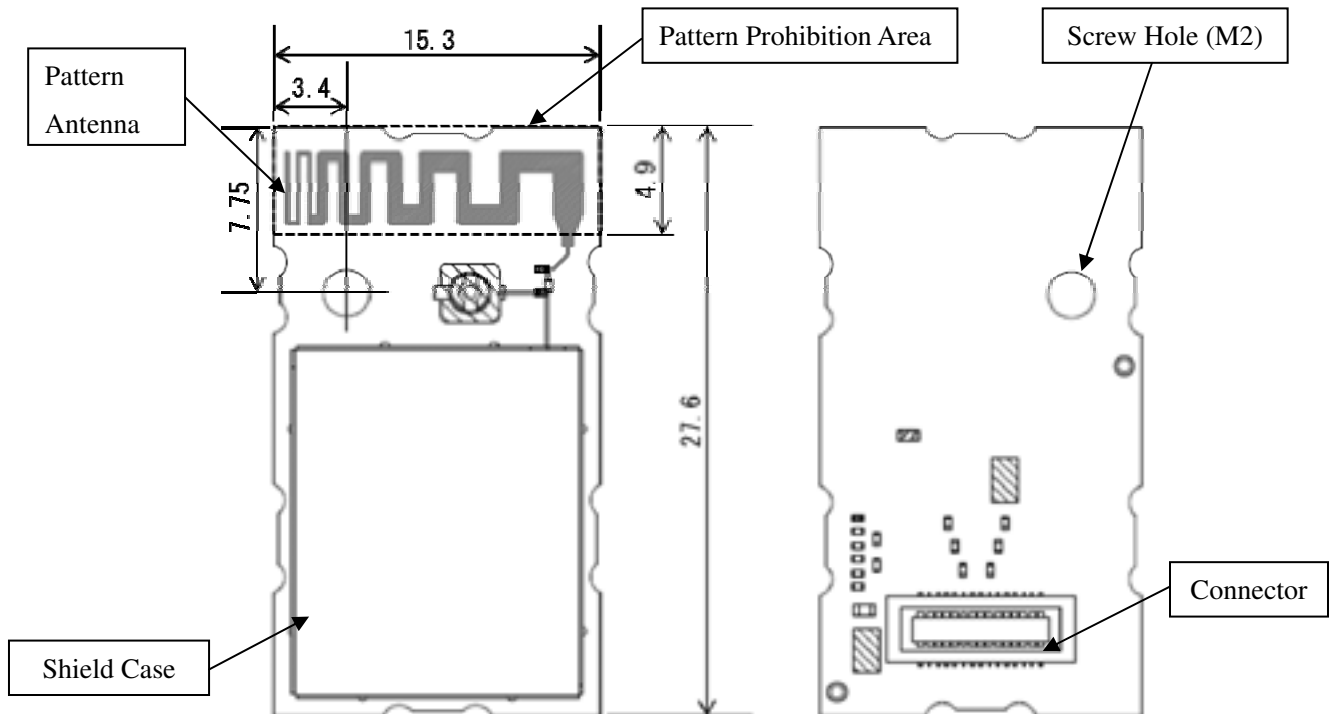

Fig.3 Precautions for Mounting (Unit : mm)

- (1) Please don't patterning the area under pattern prohibition area so that there is an adverse effect in a wireless characteristic.
- (2) Please do not set your substrates around the chip antenna within 1cm.
- (3) Please do not use metals for a chassis setting this module.
- (4) Please do not mount parts under this module except a specified connector.

11 ABOUT THE FIXATION OF THE MODULE

Please use the M2 screw (made of metal) for fixing BP3591.

Please use a spacer (made of metal) which height is 1.5mm, between your substrate and this module.

M2 screw hole is GND of BP3591. Please use a metal spacer for ground connection between BP3591 GND and your substrate GND. (Refer to the figure below)

A torque to tighten M2 screw should be more than 1kgf·cm, and do not tighten the screw too much.

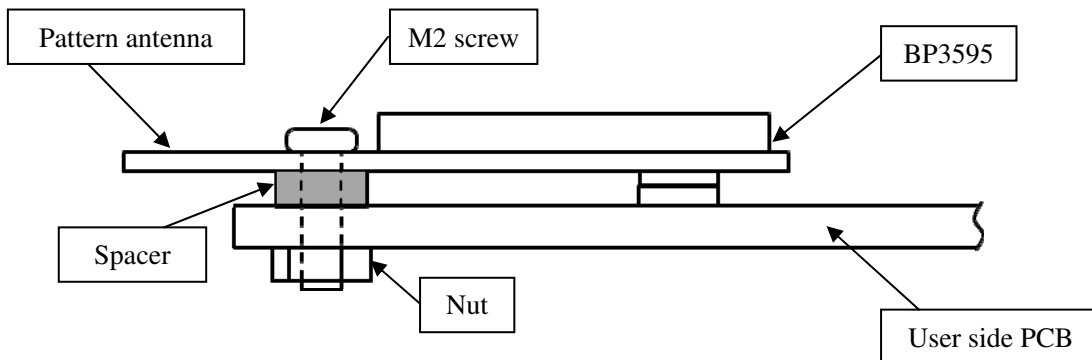

Fig.4 Fixed Module Figure (Side view)

12 PRODUCT LABEL SPEC

The label shown in the following figure is put on the shield case.



Fig.5 Product Label Spec

*Micro QR code is included in the MAC address information.

(Note)The design of product label might change without previous notice.

13 REFERENCE CIRCUIT

13-1 USB HOST INTERFACE

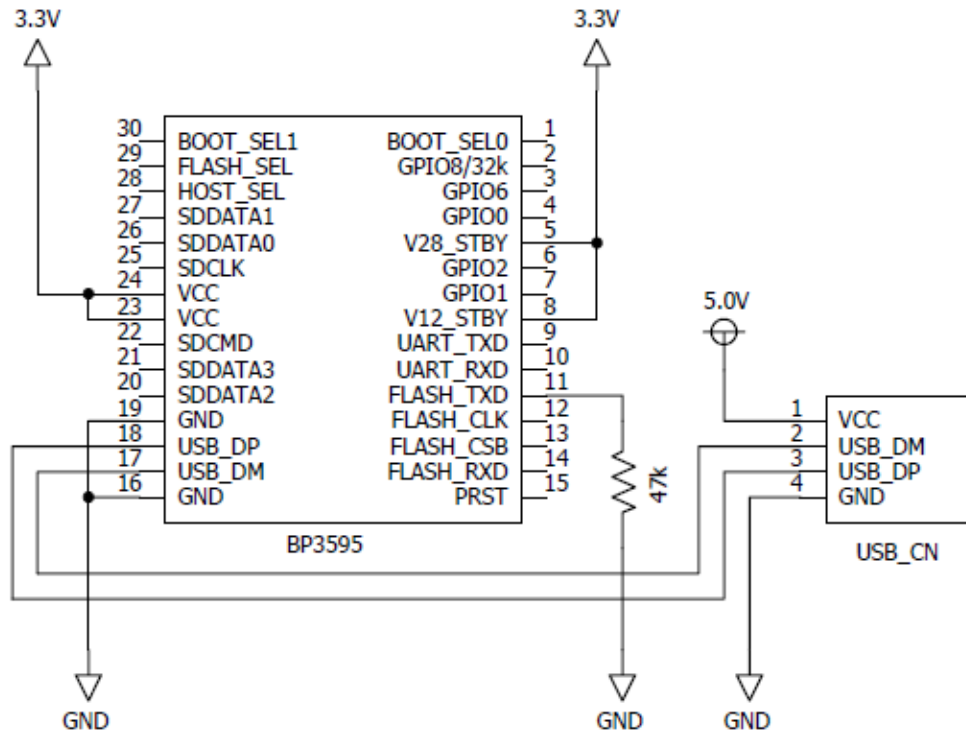

Fig.6 USB Interface Reference Circuit

*About USB_DP and USB_DM Lines

- Please shorten the wiring length as much as possible.
- Please take the differential impedance matching to $90\Omega \pm 10\%$.
- Please set up to $45\Omega \pm 10\%$ for impedance matching of single end.
- Please wire USB_DP and USB_DM lines same lengths as possible.
(Difference of the wire length is less than 0.5mm.)
- Please do not bend USB lines many times and make the bend angle small.
- Please do not make thre hole in wiring if possible.
- Please do not cross the USB lines and another signal lines.
- Please do not cross the USB lines and a power supply line.

*Please reduce the ripple of power supply (VCC=3.3V) as much as possible. (less than 10mVpp)

13-2 SDIO HOST INTERFACE

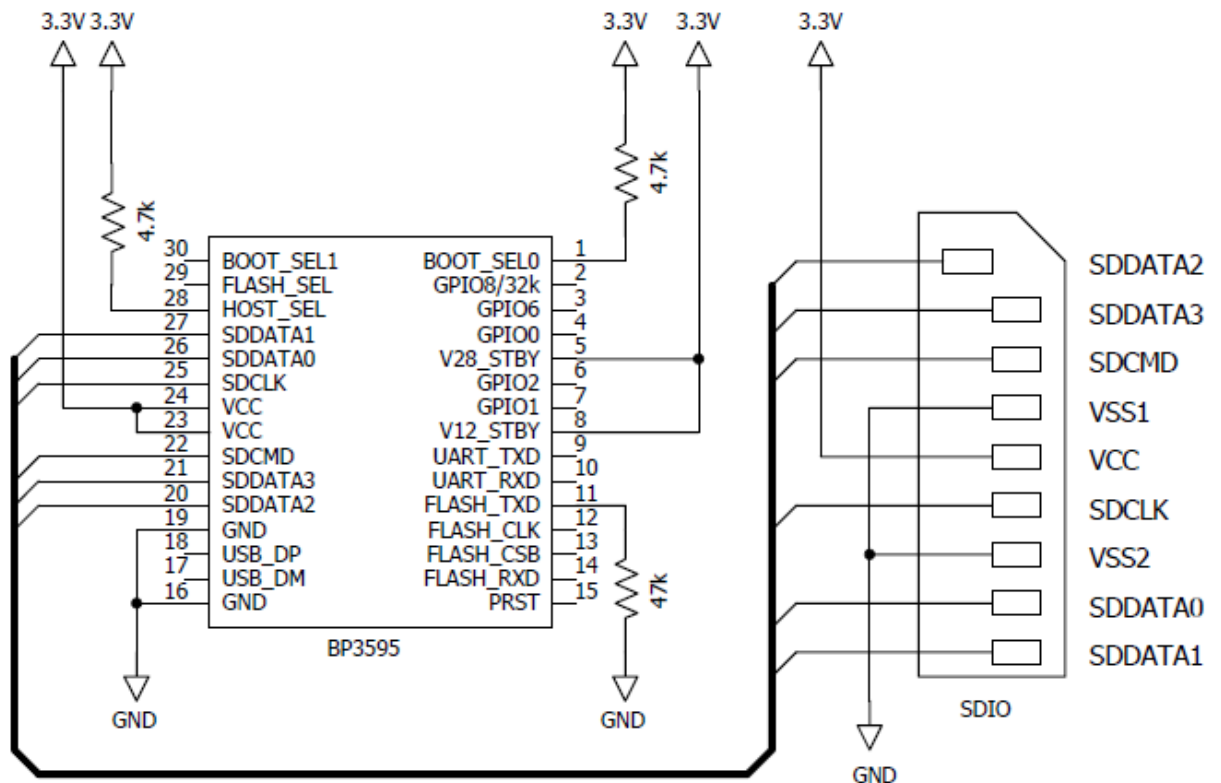

Fig.7 SDIO Interface Reference Circuit

*Please reduce the ripple of power supply (VCC=3.3V) as much as possible. (less than 10mVpp)

*About the line of SDCLK/SDDATA/SDCMD

- Over shoot and under shoot of signal lines cause a lot of damage to wireless performance. Please design so that its noise level becomes lower as possible within the SDIO standard timing.
For example it can be insert dumping resistor near the host signal source.

13-3 UART INTERFACE

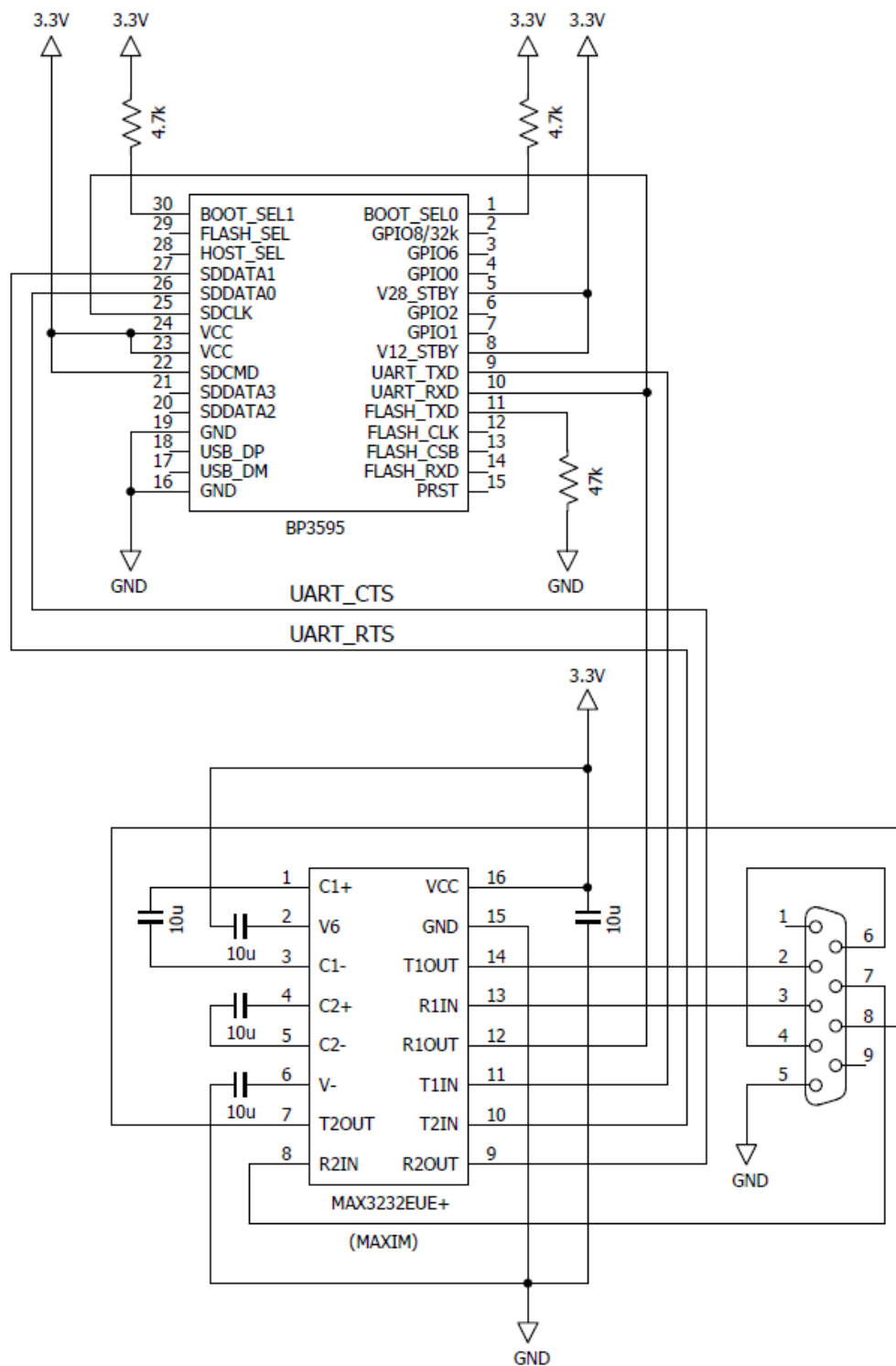
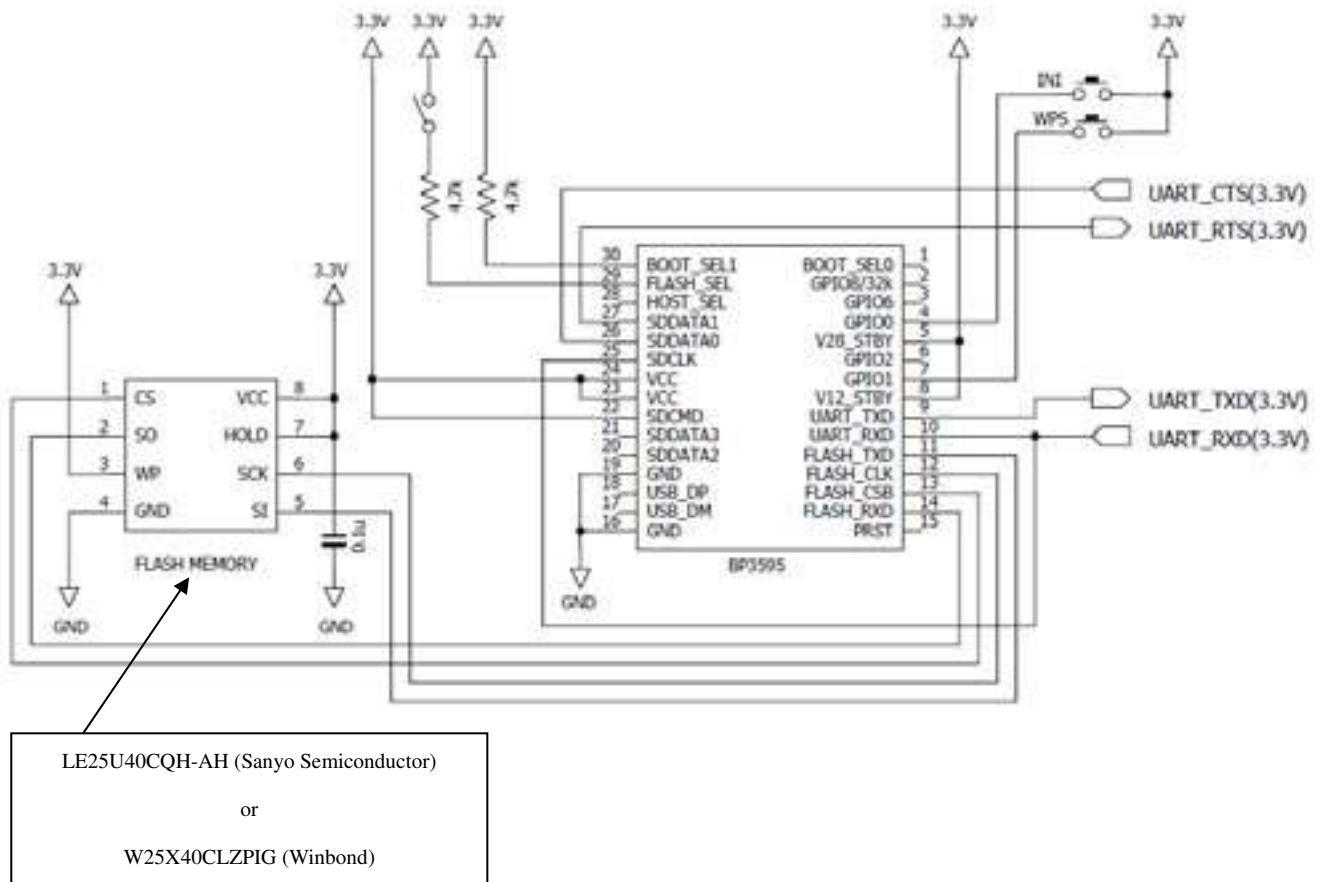

Fig.8 UART Interface Reference Circuit

*Please reduce the ripple of power supply (VCC=3.3V) as much as possible. (less than 10mVpp)

13-4 FLASH BOOT (UART INTERFACE MODE)



(*) Flash memory of above figure is S25FL032P.

Fig.9 Flash Boot (UART INTERFACE)Reference Circuit

13-5 Reset IC

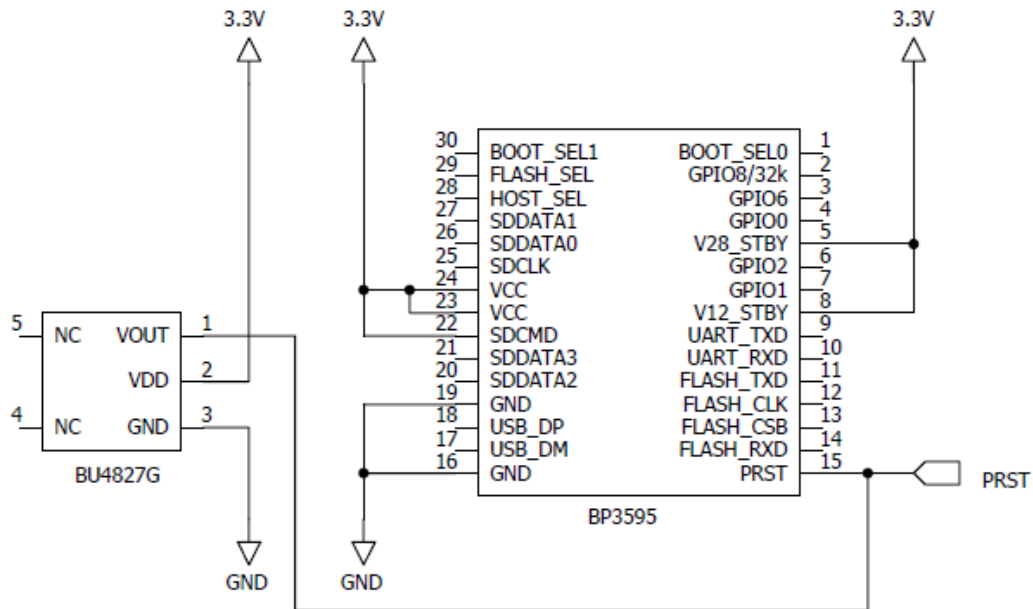

Fig.10 Reset IC Connection Reference Circuit

14 PRECAUTIONS AS RESET OPERATION

- Please do not reset (PRST, COMMAND RESET) when BP3595 is accessing to its internal EEPROM.
- BP3595 under writing to the EEPROM is reset (*), which may cause unexpected failure such as incorrect checksum.
- BP3595 under reading from the EEPROM is reset (**), which may cause unstable condition, and you should supply VCC power again.

(*) About write operations of the EEPROM

BP3595 writes to the EEPROM in the following cases.

- ① Recording various settings used in TCP/IP firmware
- ② Recording credential data which is obtained when BP3595 with stand-alone mode acts WPS

(**) About read operations of the EEPROM

BP3595 reads from the EEPROM in the following cases.

- ① After reset (≤ 100 ms)
- ② After firmware starting (≤ 100 ms)
- ③ When WID_SERIAL_NUMBER command is issued.

15 OPERATING PRECAUTIONS

- 1) There is some case that the MAC address does not become sequential number in a same package.
- 2) About soldering of mounting parts on this product, presence of soldering fillet does not be asked.
- 3) About the products label, deflections does not be asked except coming off, lapping, or not to recognize the characters extremely.
- 4) A connector is possible to break by excessive swing or shock because of the structure of the product. Efficient evaluation is necessary to use the module when there is a fear of swinging or shocking.
- 5) The connector of BP3595 does not have a specification assumed to do many times of extraction and insertion. Please be sure that the number of extraction and insertion is within 10 times.

16 PRECAUTIONS AS A WIRELESS EQUIPMENT (1)

BP3595 acquired “Construction design attestation” (Article 38-24, Clause1 of Radio Law in Japan) of “Particular wireless equipment: Low power data communications system in the 2.4GHz band, which is a Wireless equipment in Article 2-1(19)”

Therefore, only in Japan, it is possible to use as wireless equipment without applying for wireless office.

•Construction design attestation No. : 003-120319

Be sure to keep following notes to use the module safely as wireless equipment.

1) The label on the module is a certification which shows it has “Certification of technical standard conformity.”

Please do not remove the label or do not put another label on the label.

2) Please do not resolve or remodel strictly because there are some cases of receiving penalty based on Radio Law in Japan.

17 PRECAUTIONS AS A WIRELESS EQUIPMENT (2)

BP3591 acquired Federal Communications Commission (FCC Part15 Subpart C).

As long as using chip antenna, your set include BP3591 is able to use in U.S. without application of FCC.

- FCC ID: ANSBP3591

Please following the below precautions for using BP3591 as wireless equipment in U.S.

- 1) The label put on the product is a certification label shown to be acquiring "FCC certification".

Please do not remove the label or do not put another label on the label.

- 2) If FCC ID displayed on BP3591 cannot be seen from the outside, the following displays (*) are needed for your product containing BP3591.

“Contains Transmitter Module FCC ID: ANSBP3591”

or

“Contains FCC ID: ANSBP3591”

- (*) The character size can be read easily is required. However it is not required more than 8 points.

And also line break is not permit.

- 3) It is necessary to display the following texts on your product. (*)

This device complies with part 15 of the FCC Rules. Operation is subject to the following two conditions: (1) This device may not cause harmful interference, and (2) this device must accept any interference received, including interference that may cause undesired operation.

- (*) If the text cannot be displayed on your product, you should describe in a manual or a package. It is foundations that the text is indicated on a product.

- 4) It is necessary to indicate all the texts applicable to the manual of your product.
① It is necessary text for all products.

FCC CAUTION

Change or modifications not expressly approved by the party responsible for compliance could void the user's authority to operate the equipment.

- ② It is necessary text for all products. 2

This transmitter must not be co-located or operated in conjunction with any other antenna or transmitter.

- ③ A product needs a SAR examination is necessary to indicate the following texts in a manual.

A SAR examination is not required at mobile products (*) but is required at portable products (**).

- (*) Mobile product . . . The product is used separating from a human body over 20 cm.
(**) Portable product . . . The product is used by human body within 20cm.

- ③-1 It is necessary texts for a mobile product.

This equipment complies with FCC radiation exposure limits set forth for an uncontrolled environment and meets the FCC radio frequency (RF) Exposure Guidelines in Supplement C to OET65. This equipment should be installed and operated keeping the radiator at least 20cm or more away from person's body (excluding extremities: hands, wrists, feet and ankles).

- ③-2 It is necessary text for a portable product.

The available scientific evidence does not show that any health problems are associated with using low power wireless devices. There is no proof, however, that these low power wireless devices are absolutely safe. Low Power Wireless devices emit low levels of radio frequency energy (RF) in the microwave range while being used. Whereas high levels of RF can produce health effects (by heating tissue), exposure of

low-level RF that does not produce heating effects causes no known adverse health effects. Many studies of low-level RF exposures have not found any biological effects. Some studies have suggested that some biological effects might occur, but such findings have not been confirmed by additional research. [Product name (model name)] has been tested and found to comply with FCC radiation exposure limits set forth for an uncontrolled environment and meets the FCC radio frequency (RF) Exposure Guidelines in Supplement C to OET65. The maximum SAR levels tested for [Product name (model name)] has been shown to be [SAR measurement value] W/kg at Body.

FCC does not request to mention of a SAR measurement value.

●Precautions for Safety

1) The products are designed and produced for application in ordinary electronic equipment (AV equipment, OA equipment, telecommunication equipment, home appliances, amusement equipment, etc.).

If the products are to be used in devices requiring extremely high reliability (medical equipment, transport equipment, aircraft/spacecraft, nuclear power controllers, fuel controllers, car equipment including car accessories, safety devices, etc.) and whose malfunction or operational error may endanger human life and sufficient fail-safe measures, please consult with the ROHM sales staff in advance. If product malfunctions may result in serious damage, including that to human life, sufficient fail-safe measures must be taken, including the following:

- [a] Installation of protection circuits or other protective devices to improve system safety
- [b] Installation of redundant circuits in the case of single-circuit failure

2) The products are designed for use in a standard environment and not in any special environments.

Application of the products in a special environment can deteriorate product performance. Accordingly, verification and confirmation of product performance, prior to use, is recommended if used under the following conditions:

- [a] Use in various types of liquid, including water, oils, chemicals, and organic solvents
- [b] Use outdoors where the products are exposed to direct sunlight, or in dusty places
- [c] Use in places where the products are exposed to sea winds or corrosive gases, including Cl₂, H₂S, NH₃, SO₂, and NO₂
- [d] Use in places where the products are exposed to static electricity or electromagnetic waves
- [e] Use in environment subject to strong vibration and impact.
- [f] Use in proximity to heat-producing components, plastic cords, or other flammable items
- [g] Use involving sealing or coating the products with resin or other coating materials
- [h] Use of the products in places subject to dew condensation

3) The products might receive the radio wave interference from electronic devices such as Wireless LAN devices, Bluetooth devices, digital cordless telephone, microwave oven and so on that radiate electromagnetic wave.

4) The products are not radiation resistant.

- 5) Verification and confirmation of performance characteristics of products, after on-board mounting, is advised.
- 6) Confirm that operation temperature is within the specified range described in product specification.
- 7) Failure induced under deviant condition from what defined in the product specification can not be guaranteed.
- 8) This product is a specification to radiate the radio wave. It is necessary to acquire the attestation of decided Radio Law of each region used to use the equipment that radiates the radio wave. Please inquire about the attestation of Radio Law that this product acquires.
- 9) When product safety related problems arises, please immediately inform to ROHM, and consider technical counter measure.

●Precautions for Reference Circuits

- 1) If change is made to the constant of an external circuit, allow a sufficient margin due to variations of the characteristics of the products and external components, including transient characteristics, as well as static characteristics.
- 2) The reference circuit examples, their constants, and other types of information contained herein are applicable only when the products are used in accordance with standard methods. Therefore, if mass production is intended, sufficient consideration to external conditions must be made.

●Precaution for Electrostatic

This product is Electrostatic sensitive product, which may be damaged due to Electrostatic discharge. Please take proper caution during manufacturing and storing so that voltage exceeding Product maximum rating won't be applied to products. Please take special care under dry condition (Grounding of human body / equipment / solder iron, isolation from charged objects, setting of Ionizer, friction prevention and temperature / humidity control etc.)

● **Precaution for Storage / Transportation**

- 1) Product performance and connector mating may deteriorate if the products are stored in the following places:
 - [a] Where the products are exposed to sea winds or corrosive gases, including Cl₂, H₂S, NH₃, SO₂ and NO₂
 - [b] Where the temperature or humidity exceeds those recommended by the Company
Temperature: 5°C ~ 40°C, Humidity 40% ~ 60%
 - [c] Storage in direct sunshine or condensation.
 - [d] Storage in high Electrostatic.
- 2) Even under ROHM recommended storage condition, connector mating of products over 1 year old may be degraded.
- 3) Store / transport cartons in the correct direction, which is indicated on a carton as a symbol, otherwise bent leads may occur due to excessive stress applied when dropping of a carton..

● **Precaution for Product Label**

QR code printed on ROHM product label is only for internal use, and please do not use at customer site.

It might contain a internal part number that is inconsistent with an product part number.

● **Precaution for Disposition**

When disposing products please dispose them properly with a industry waste company.

● **Prohibitions Regarding Industrial Property**

- 1) These Specifications contain information related to the ROHM industrial property. Any use of them other than pertaining to the usage of appropriate products is not permitted. Duplication of these Specifications and its disclosure to a third party without the Company's permission is prohibited.

2) Information and data on products, including application examples, contained in these specifications are simply for reference; the Company does not guarantee any industrial property rights, intellectual property rights, or any other rights of a third party regarding this information or data. Accordingly, the Company does not bear any responsibility for:

[a] infringement of the intellectual property rights of a third party

[b] any problems incurred by the use of the products listed herein.

3) The Company prohibits the purchaser of its products to exercise or use the intellectual property rights, industrial property rights, or any other rights that either belong to or are controlled by the Company, other than the right to use, sell, or dispose of the products.