

NOTES:

1. STANDARD PART SET UP AS ASP.
2. $\text{\textcircled{C}}$ REPRESENTS A CRITICAL DIMENSION.
3. MAXIMUM BURR ALLOWANCE: .038 [.0015].
4. MINIMUM PUSHOUT FORCE: 2.22N [.5LB].
5. PARTS TO BE PACKAGED IN TAPE & REEL.

REVISION

A	TP	D FRALEY
1/12/2011	ECN-146422	
RELEASE FOR PRODUCTION		
B	VZ	B ASHLEY
6/30/2014	ECN-231198	
BCM CIG ITEM4 FROMK 500 300 TO K DOT-236-343-005		

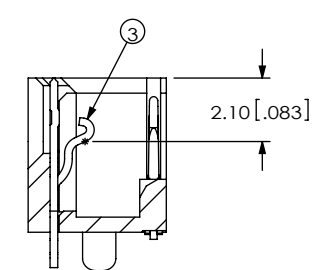
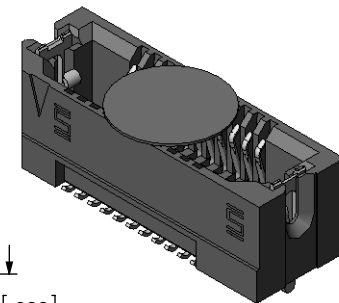
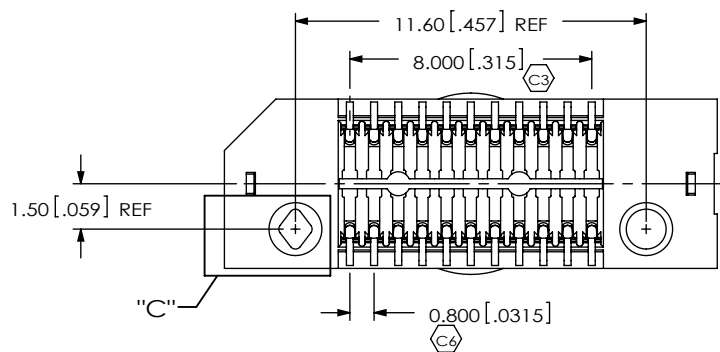
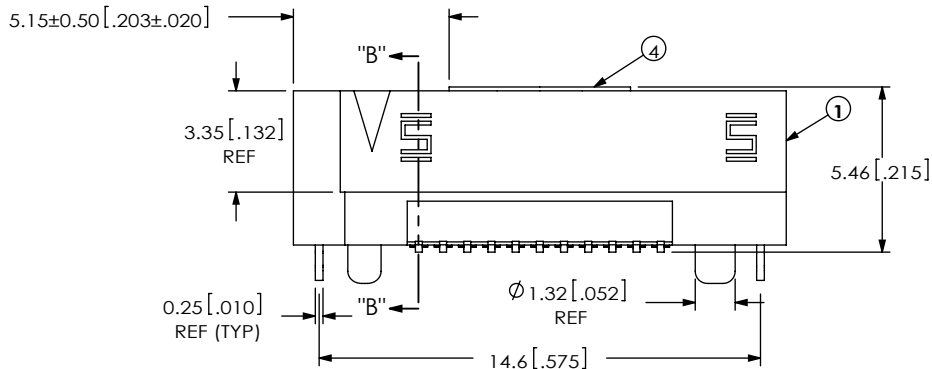
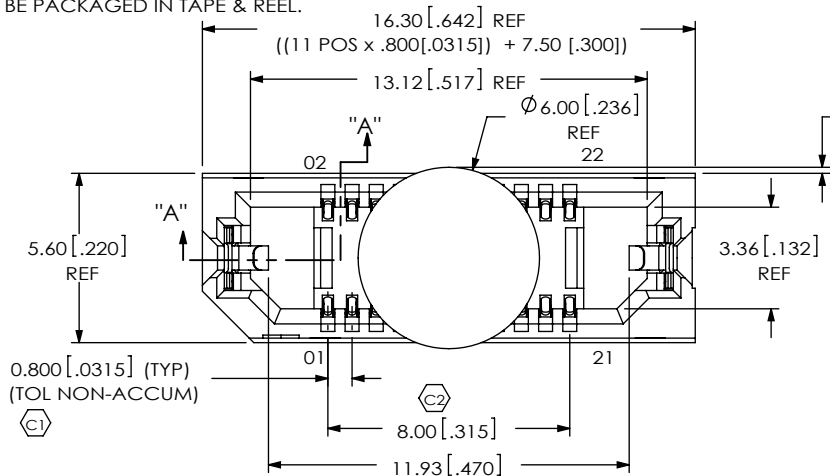

SECTION "A"- "A"
SCALE 4 : 1

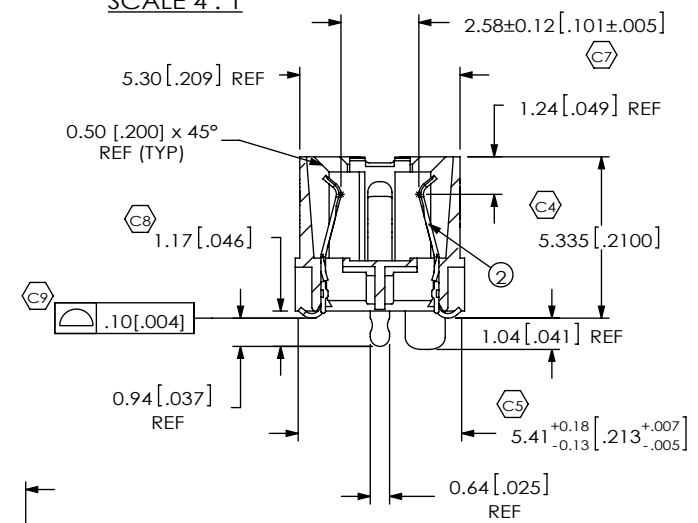

SECTION "B"- "B"
SCALE 4 : 1

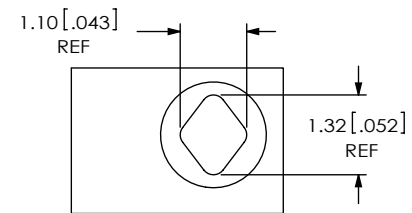

DETAIL "C"
SCALE 8 : 1

ACCEPTANCE OF DRAWING
ACCEPTED WITH DEVIATIONS LISTED

DATE: _____
COMPANY: _____
CUSTOMER SIGNATURE: _____
PRINTED NAME: _____
PHONE NO: _____
FAX NO: _____

UNLESS OTHERWISE SPECIFIED, DIMENSIONS ARE IN MILLIMETERS. TOLERANCES ARE: DECIMALS ANGLES .X: ±.3[.01] 2° .XX: ±.13[.005] .XXX: ±.051[.0020]	PROPRIETARY NOTE THIS DOCUMENT CONTAINS INFORMATION CONFIDENTIAL AND PROPRIETARY TO SAMTEC, INC. AND SHALL NOT BE REPRODUCED OR TRANSFERRED TO OTHER DOCUMENTS OR DISCLOSED TO OTHERS OR USED FOR ANY PURPOSE OTHER THAN THAT WHICH IT WAS OBTAINED WITHOUT THE EXPRESSED WRITTEN CONSENT OF SAMTEC, INC.	520 PARK EAST BLVD, NEW ALBANY, IN 47150 PHONE: 812-944-6733 FAX: 812-948-5047 e-Mail info@SAMTEC.com code 55322
PLATING: CONTACT AREA: .000030 GOLD OVER .000050 NICKEL REMAINDER: .000200 REF TIN OVER .000050 NICKEL LATCHES: .000003 GOLD OVER .000050 NICKEL		DWG. NO. ASP-137969-02
F:\DWG\SW\ASP\137000\ASP-137969-02.SLDDRW		BY: TIM P. 01/12/2011 SHEET 1 OF 3

ITEM NO.	PART NUMBER	QUANTITY	MATERIAL
1	ERF8-011-05.0-DV-L	1.0000	VECTRA E130i, COLOR: BLACK
2	C-211-05.0-S	22.0000	BeCu, 390 HT
3	WT-30-01-F	2.0000	BeCu, #25, 1/2 HT
4	K-DOT-.236-.343-005	1.0000	POLYIMIDE FILM
5	CT-ERF8034MS	1.0000	CONDUCTIVE POLYMER

[B]

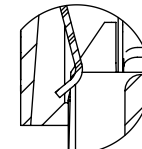
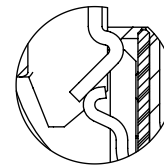
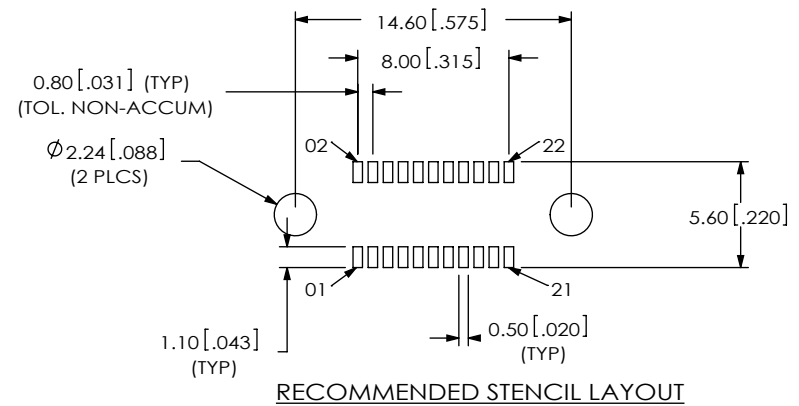
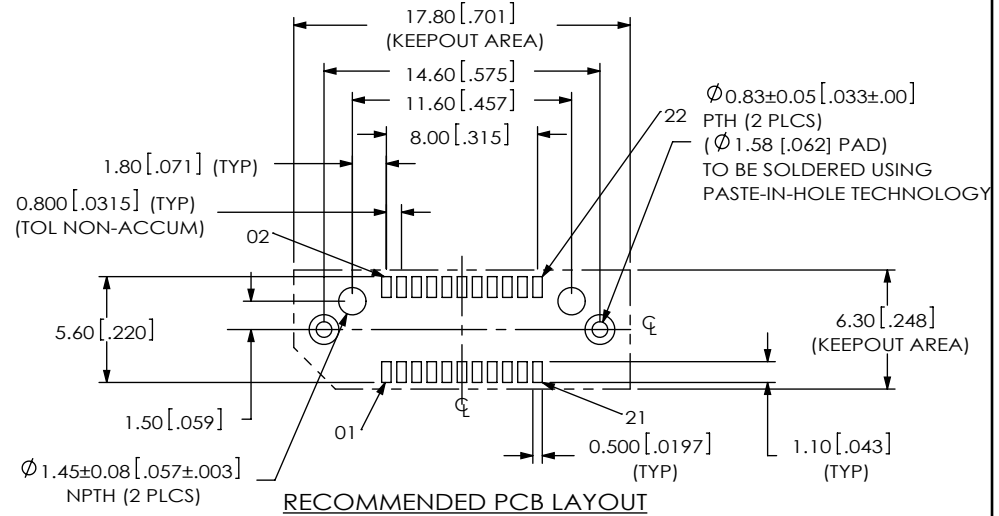
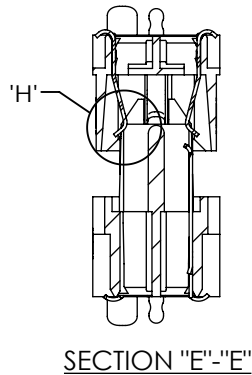
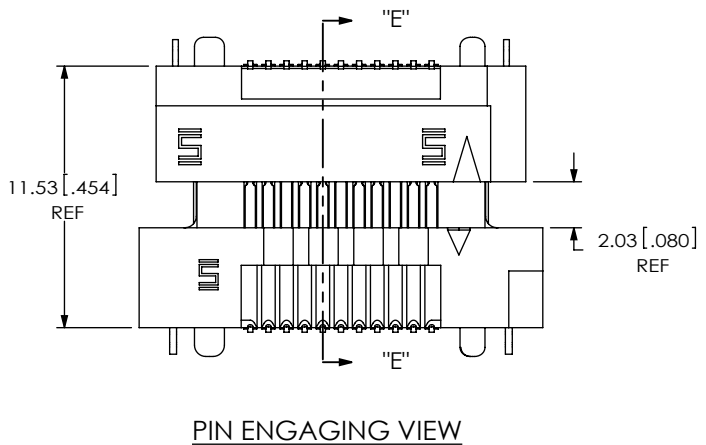
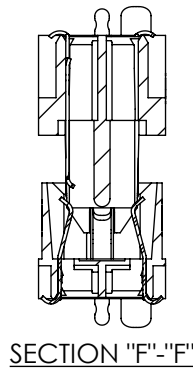
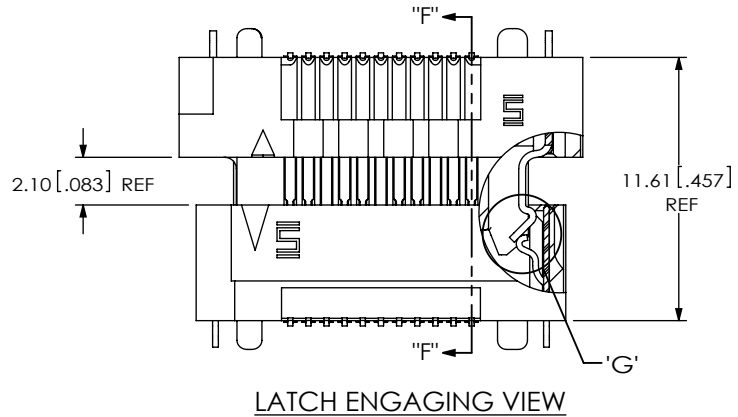

PROPRIETARY NOTE

THIS DOCUMENT CONTAINS INFORMATION CONFIDENTIAL AND PROPRIETARY TO SAMTEC, INC. AND SHALL NOT BE REPRODUCED OR TRANSFERRED TO OTHER DOCUMENTS OR DISCLOSED TO OTHERS OR USED FOR ANY PURPOSE OTHER THAN THAT WHICH IT WAS OBTAINED WITHOUT THE EXPRESSED WRITTEN CONSENT OF SAMTEC, INC.



520 PARK EAST BLVD. NEW ALBANY, IN 47150
PHONE: 812-944-6733 FAX: 812-948-5047
e-Mail info@SAMTEC.com code 55322

SHEET SCALE: 3:1

DESCRIPTION: MODIFIED ERF8 ASSEMBLY

DWG. NO. ASP-137969-02

BY: TIM P. 01/12/2011 SHEET 2 OF 3

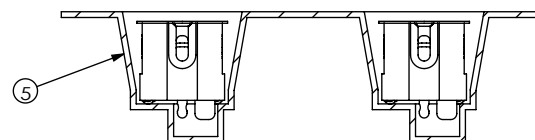
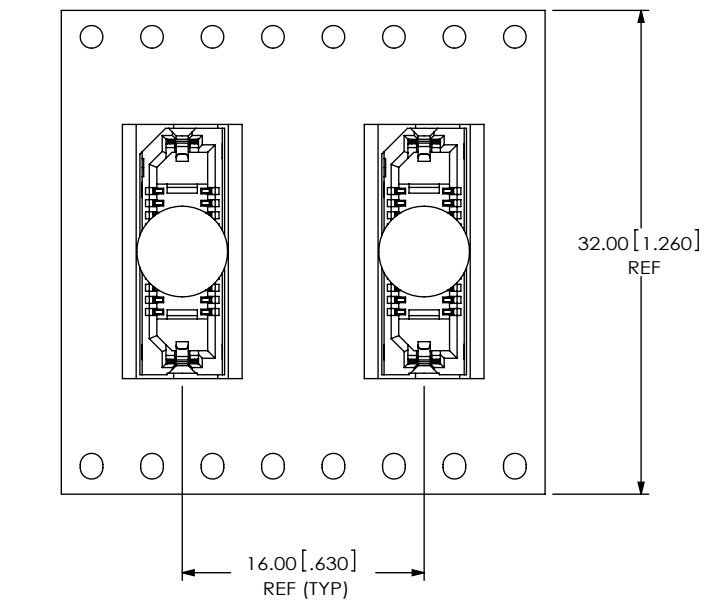

USER DIRECTION OF UNREELING →
POCKET NOT DETAILED

PACKAGING VIEW

PROPRIETARY NOTE

THIS DOCUMENT CONTAINS INFORMATION CONFIDENTIAL AND PROPRIETARY TO SAMTEC, INC. AND SHALL NOT BE REPRODUCED OR TRANSFERRED TO OTHER DOCUMENTS OR DISCLOSED TO OTHERS OR USED FOR ANY PURPOSE OTHER THAN THAT WHICH IT WAS OBTAINED WITHOUT THE EXPRESSED WRITTEN CONSENT OF SAMTEC, INC.



520 PARK EAST BLVD, NEW ALBANY, IN 47150
PHONE: 812-944-6733 FAX: 812-948-5047
e-Mail: info@SAMTEC.com code 55322

SHEET SCALE: 1:1

DESCRIPTION:
MODIFIED ERF8 ASSEMBLY

DWG. NO.
ASP-137969-02

BY: TIM P. 01/12/2011 SHEET 3 OF 3