

# 10GBASE-T TRANSFORMER MODULES

Ruggedized

10GB-6014

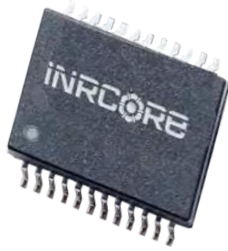

- Compliant with IEEE 802.3 standards
- Dielectric Withstanding Voltage: 1500Vrms
- Operating temperature: -40°C to +125°C
- Storage temperature: -55°C to +125°C
- Terminal finish: Sn/Pb, (Pure tin for RoHS version)
- MSL: 3

## Electrical Specifications @ 25°C

Part Number	Insertion Loss (dB Max)			Return Loss (dB Min)					Crosstalk (dB Min)				DM to CM Rejection Ratio (dB Min)			Dielectric Withstanding Voltage @5s (Vrms MIN)
	100 KHz	1-300 MHz	400-500 MHz	1 MHz	100 MHz	300 MHz	400 MHz	500 MHz	1 MHz	100 MHz	400 MHz	500 MHz	1 MHz	250 MHz	500 MHz	
10GB-6014	-3.0	-1.2	-2.4	-22	-20	-12	-10	-8	-40	-37	-30	-25	-40	-30	-22	1500

Notes: 1. Add suffix "T" to part number for Tape & Reel package (i.e.: **10GB-6010T**). 2. Add suffix NL for RoHS compliant part; i.e. (**10GB-6010NL**).

## Mechanical

### 10GB-6014

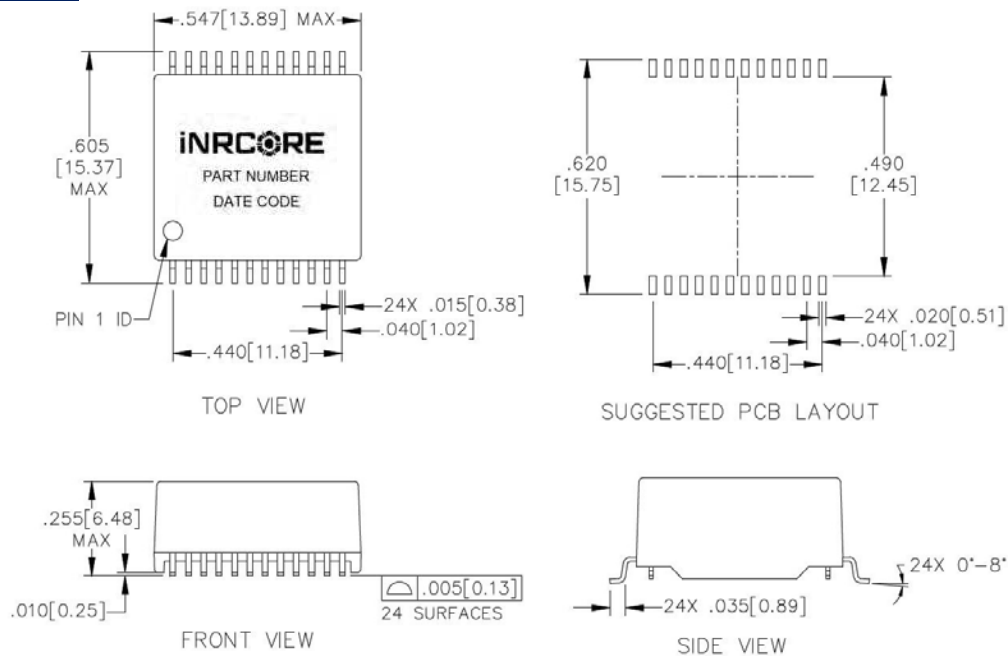

Dimensions: inches[mm]  
 Unless otherwise specified,

Weight.....TBD  
 Tube.....TBD



## Schematic

### 10GB-6014

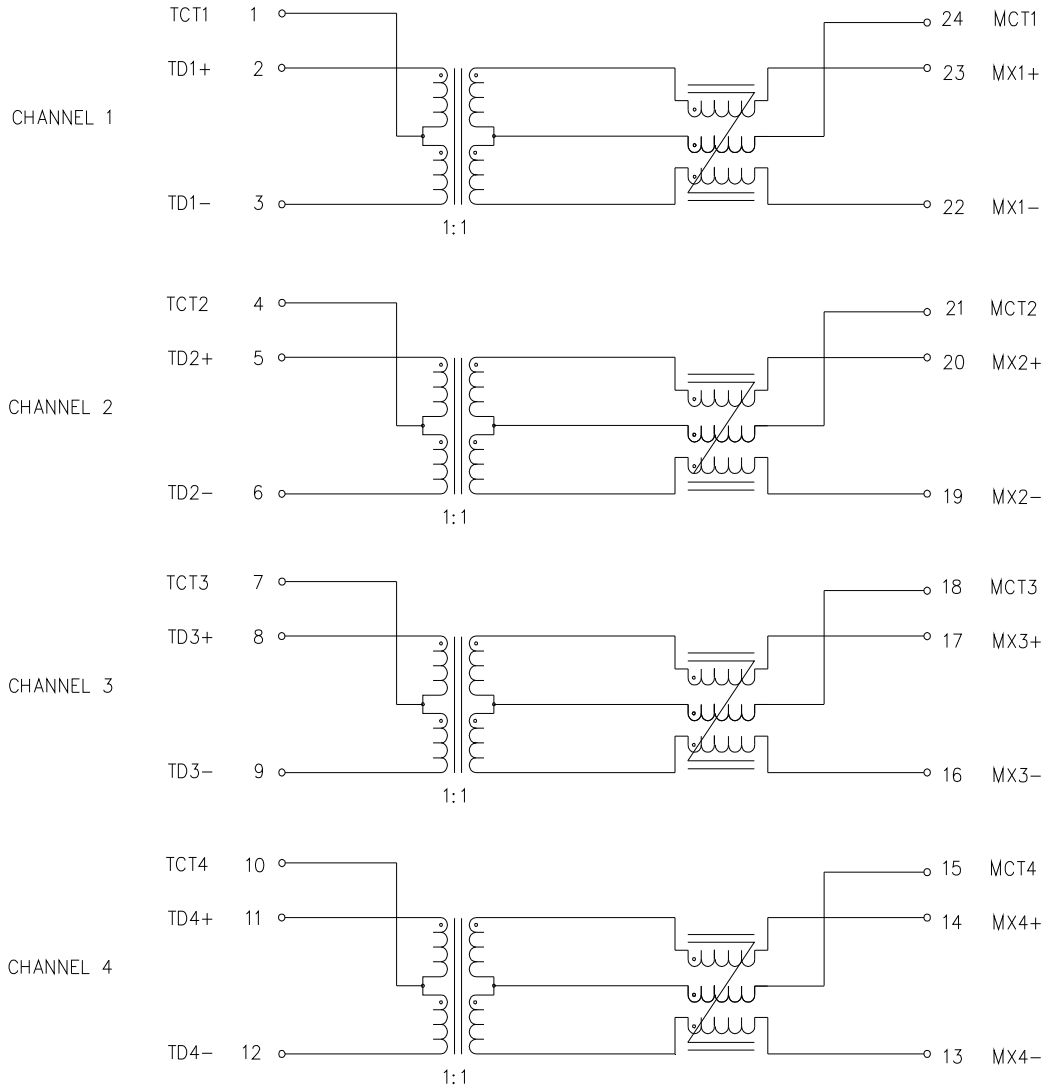

#### LEGEND

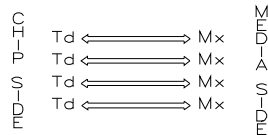

ALL CHANNELS ARE  
IN PHASE BETWEEN  
INPUT AND OUTPUT



**Tin/Lead Recommended Reflow Profile (Based on J-STD-020D)**

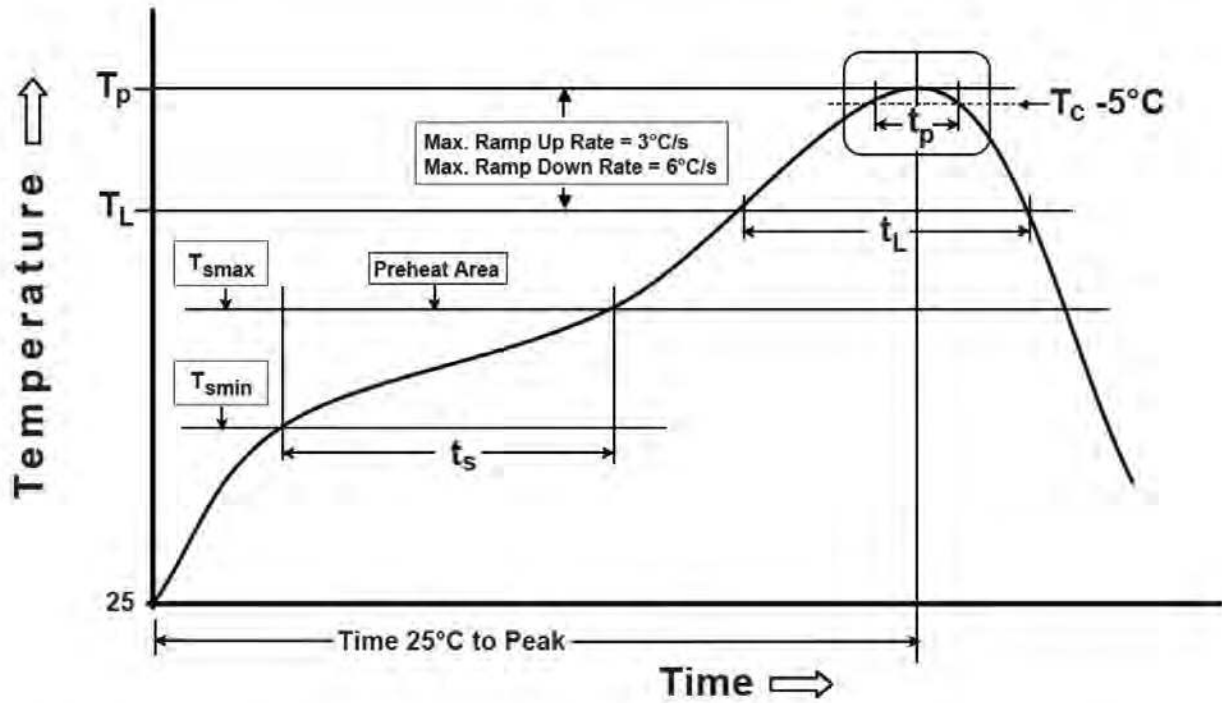

$T_{SMIN}$ (°C)	$T_{SMAX}$ (°C)	$T_L$ (°C)	$T_P$ (°C MAX)	$t_s$ (s)	$t_L$ (s)	$t_p$ (s MAX)	Ramp-up rate ( $T_L$ to $T_P$ )	Ramp-down rate ( $T_P$ to $T_L$ )	Time 25°C to peak temperature (s MAX)
100	150	183	235	60-120	60-150	20	3°C/s MAX	6°C/s MAX	360

Notes:

1. All temperatures measured on the package leads.
2. Maximum times of reflow cycle: 2.

**Non-Lead Recommended Reflow Profile (Based on J-STD-020D)**

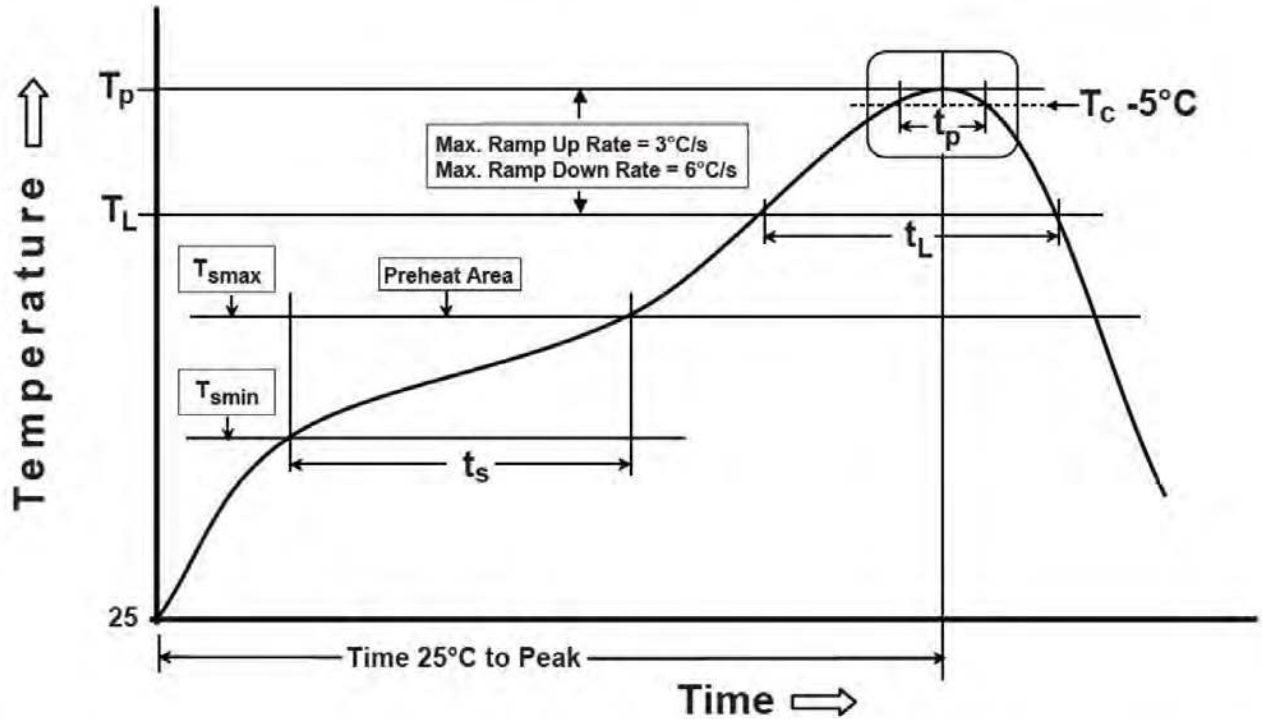

$T_{SMIN}$ (°C)	$T_{SMAX}$ (°C)	$T_L$ (°C)	$T_P$ (°C MAX)	$t_s$ (s)	$t_L$ (s)	$t_p$ (s MAX)	Ramp-up rate ( $T_L$ to $T_P$ )	Ramp-down rate ( $T_P$ to $T_L$ )	Time 25°C to peak temperature (s MAX)
150	200	217	245	60-120	60-150	30	3°C/s MAX	6°C/s MAX	480

Notes:

1. All temperatures measured on the package leads.
2. Maximum times of reflow cycle: 2.

**For More Information**

iNRCORE, LLC  
311 Sinclair Road Bristol,  
PA 19007-6812 U.S.A  
Tel: + 1.215.781.6400  
Fax: +1.215.7816430

**Global Sales Representatives and Locations:**  
<http://www.inrcore.com>

Performance warranty of products offered on this data sheet is limited to the parameters specified. Data is subject to change without notice. Other brand and product names mentioned herein may be trademarks or registered trademarks of their respective owners. © Copyright, 2020. iNRCORE, LLC. All rights reserved.

