

### IGBT Gate Driver + DC/DC Converter

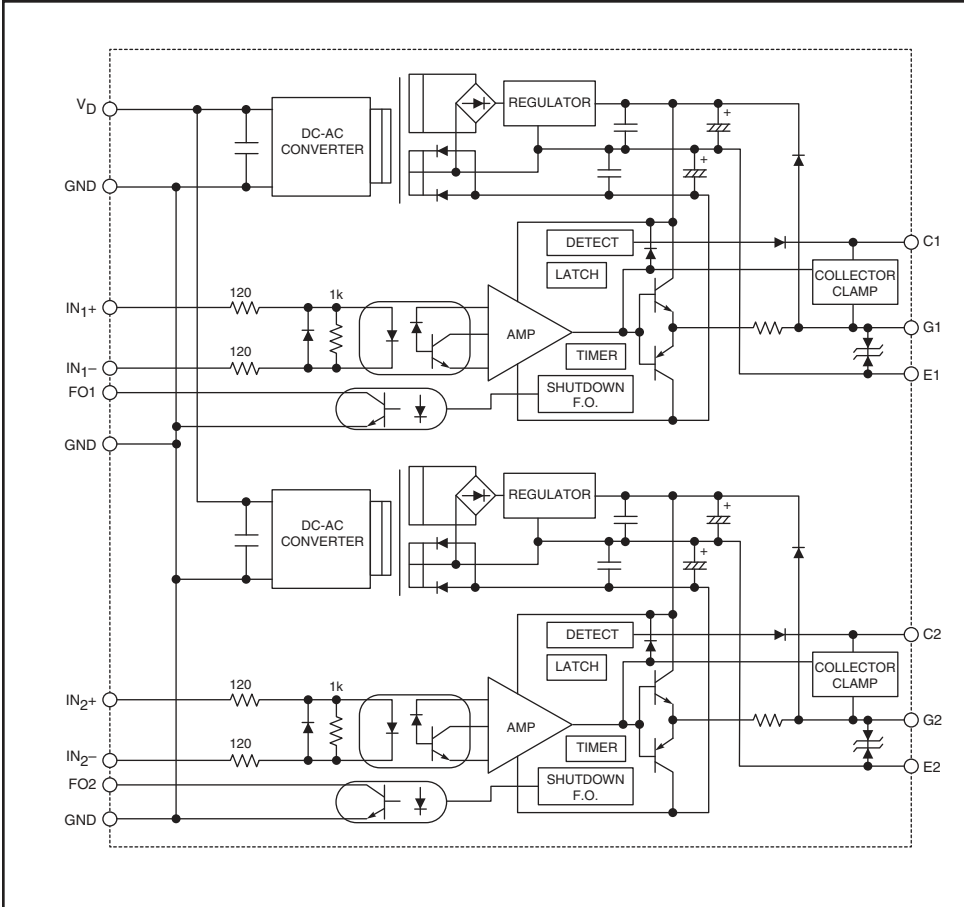

Circuit Diagram



#### Description:

VLA553-01R / -02R is a hybrid integrated circuit designed for driving IGBT modules in the new Mega Power Dual package.

#### Features:

- Directly Mountable on the New MPD
- Built in Isolated DC-DC Converter for Gate Drive
- Output Peak Current is  $\pm 24A$  (max)
- Built in Short Circuit Protection with Soft Shutdown
- Built in Collector Clamp Circuit
- Electrical Isolation Voltage 4000  $V_{rms}$  (for 1 Minute)
- CMOS Compatible Input Interface

#### Applications:

- Gate Driver for 1200V and 1700V New Mega Power Dual IGBT Modules

#### Recommended IGBT Modules:

CM2500DY-24S – VLA553-01R  
 CM1800DY-34S – VLA553-02R

**VLA553-01R / -02R**  
**IGBT Gate Driver + DC/DC Converter**

**Absolute Maximum Ratings,  $T_a = 25^\circ\text{C}$  unless otherwise specified**

Characteristics	Symbol	Rating	Units
Supply Voltage (DC)	$V_D$	-1 ~ 16.5	Volts
Input Signal Voltage (Applied Between IN+ and IN-, 50% Duty Cycle, Pulse Width 1ms)	$V_I$	-7 ~ +7	Volts
Output Peak Current (Pulse Width 3 $\mu$ s)	$I_{OHP}$	-24	Amperes
	$I_{OLP}$	24	Amperes
Isolation Voltage (Sine Wave Voltage 60Hz, for 1 min.)	$V_{iso}$	4000	$V_{rms}$
Operating Temperature (No Condensation Allowable)	$T_{opr}$	-25 ~ 70	$^\circ\text{C}$
Storage Temperature (No Condensation Allowable)	$T_{stg}$	-40 ~ 85	$^\circ\text{C}$
Gate Drive Current, Gate Average Current (Per One Circuit)	$I_{drive}$	210	mA
Main Circuit Voltage (Voltage Between P and N)	$V_{DC\_Link}$	840 (-01R)	Volts
	$V_{DC\_Link}$	1200 (-02R)	Volts

**Electrical Characteristics,  $T_a = 25^\circ\text{C}$ ,  $V_D = 15\text{V}$ ,  $f = 3\text{kHz}$  unless otherwise specified**

Characteristics	Symbol	Test Conditions	Min.	Typ.	Max.	Units
Supply Voltage	$V_D$	Recommended Range	14.2	15	15.8	Volts
Pull-up Voltage on Input Side	$V_{IN}$	Recommended Range (For Input Signal)	4.75	5	5.25	Volts
"H" Input Signal Current	$I_{IH}$	Recommended Range	10	12	16	mA
Switching Frequency	$f$	Recommended Range	—	—	5	kHz
Gate Resistance	$R_G$	Recommended Range	0	—	—	$\Omega$
Plus Bias Output Voltage	$V_{OH}$		14	15.3	16.5	Volts
Minus Bias Output Voltage	$V_{OL}$		-5.5	-7	-11	Volts
"L-H" Propagation Time	$t_{PLH}$	$I_{IH} = 12\text{mA}$	0.3	—	1	$\mu\text{s}$
"H-L" Propagation Time	$t_{PHL}$	$I_{IH} = 12\text{mA}$	0.3	—	1	$\mu\text{s}$
Clamp Zener Voltage	$V_Z^{*1}$	Total Zener Voltage in Collector	901	950 (-01R)	999	Volts
		Clamp Circuit at $I_Z = 1\text{mA}$ , $T_j = 25^\circ\text{C}$	1284	1350 (-02R)	1419	Volts
SC Detect Voltage	$V_{SC}$		15	—	—	Volts

\*1 It depends on the condition of use, however actual clamp voltage of collector rises by 300V from 200V to  $V_Z$ .

**VLA553-01R / -02R**  
**IGBT Gate Driver + DC/DC Converter**

**Application Example**

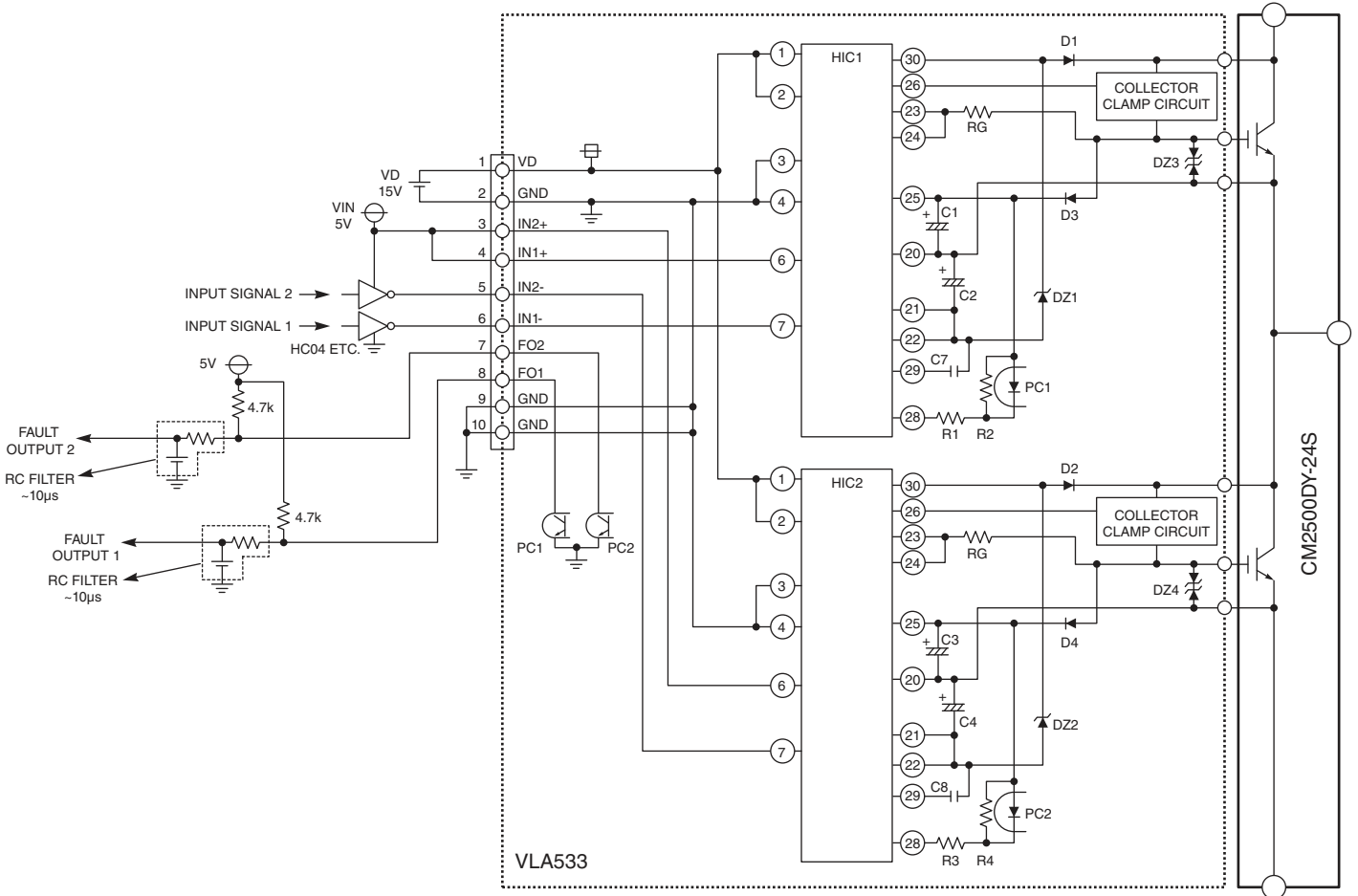

VLA553-01R / -02R  
IGBT Gate Driver + DC/DC Converter

$V_{CC}$ ,  $V_{EE}$  |  $T_a$  CHARACTERISTICS (TYPICAL)

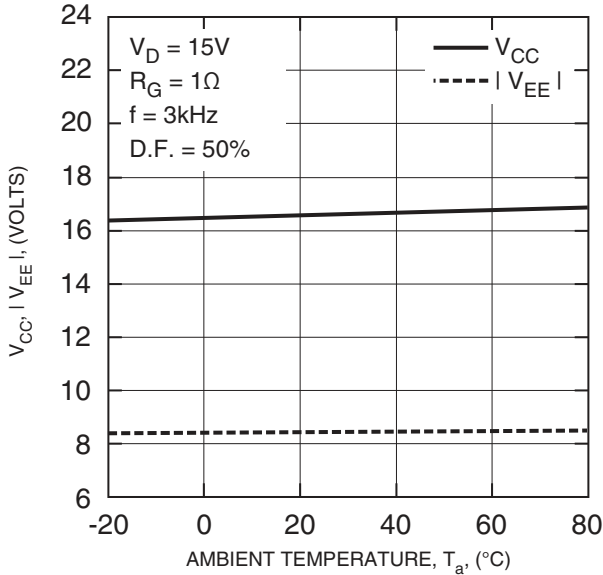

$V_{CC}$ ,  $V_{EE}$  |  $I_O$  CHARACTERISTICS (TYPICAL)

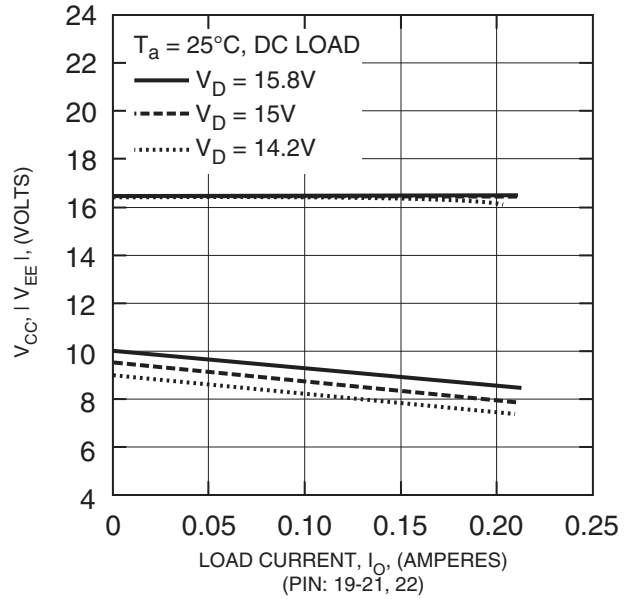

$t_{PLH}$ ,  $t_{PHL}$ - $T_a$  CHARACTERISTICS (TYPICAL)

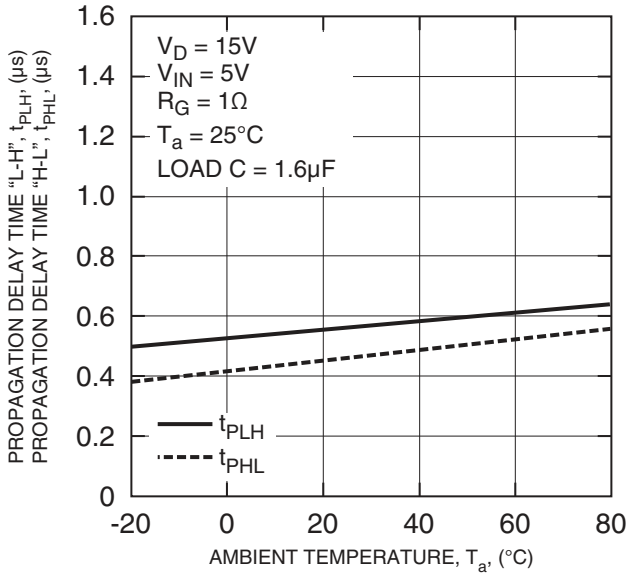

$t_{PLH}$ ,  $t_{PHL}$ - $V_I$  CHARACTERISTICS (TYPICAL)

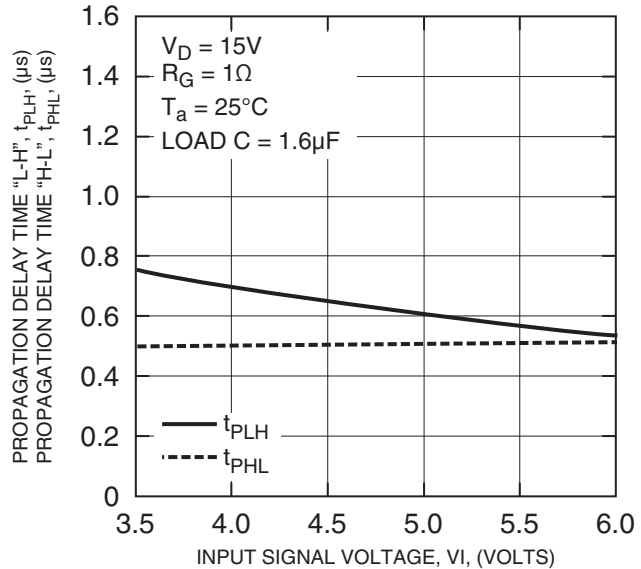

VLA553-01R / -02R  
IGBT Gate Driver + DC/DC Converter

**$t_{trip}$ - $T_a$  CHARACTERISTICS (TYPICAL)**

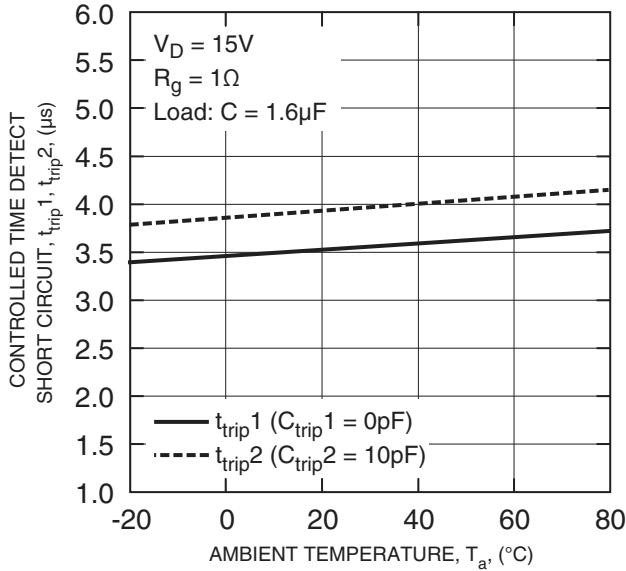

**$t_{trip}$ - $C_{trip}$  CHARACTERISTICS (TYPICAL)**

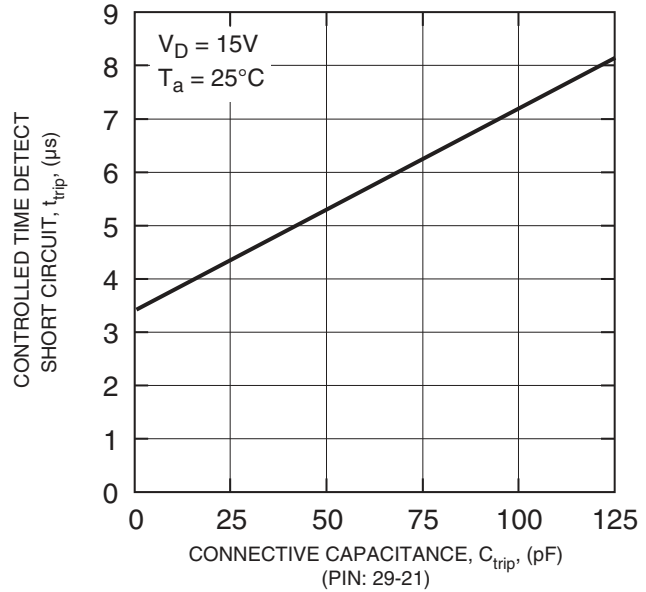

**$I_D$ - $I_O$  CHARACTERISTICS (TYPICAL)**

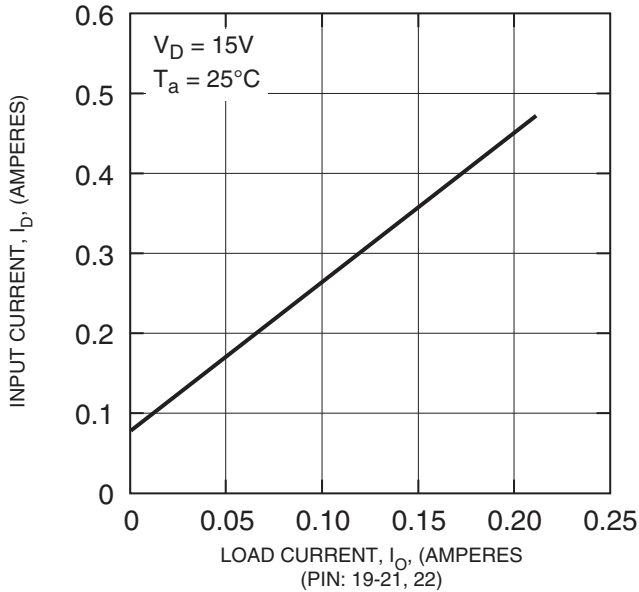

**$V_{OH}$ ,  $V_{OL}$  -  $T_a$  CHARACTERISTICS (TYPICAL)**

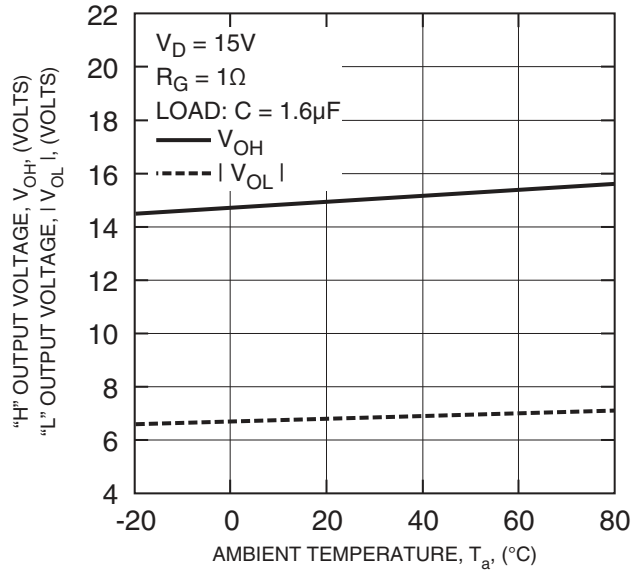

VLA553-01R / -02R  
IGBT Gate Driver + DC/DC Converter

$\eta$ - $I_{drive}$  CHARACTERISTICS  
(TYPICAL)

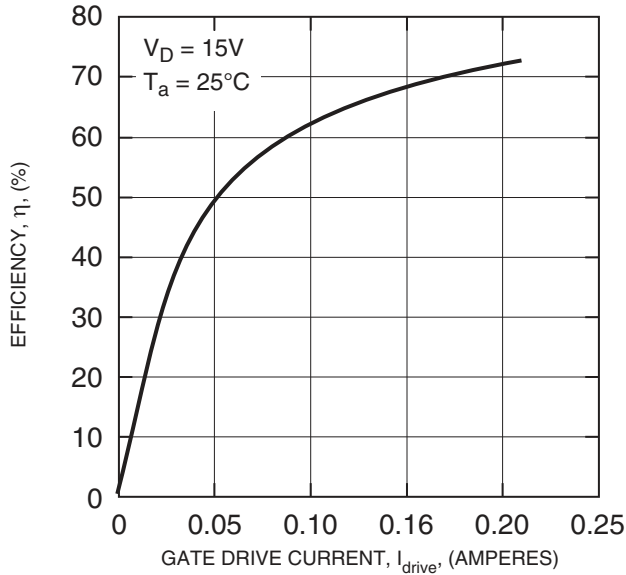

$V_{CC}$ ,  $|V_{EE}|$  - $V_D$  CHARACTERISTICS  
(TYPICAL)

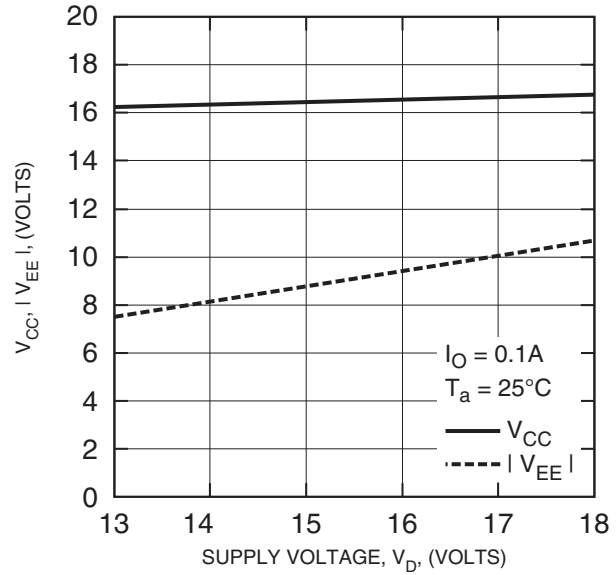

$I_{drive}$ - $T_a$  CHARACTERISTICS  
(TYPICAL)

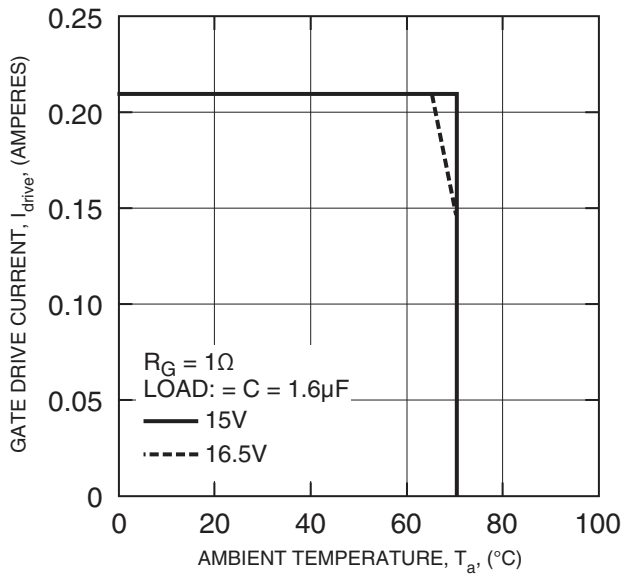

$\eta$ - $V_D$  CHARACTERISTICS  
(TYPICAL)

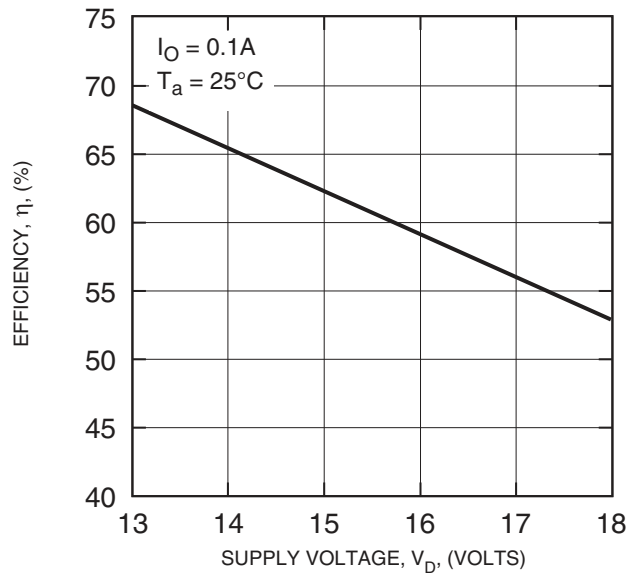

VLA553-01R / -02R  
IGBT Gate Driver + DC/DC Converter

TOTAL ZENER VOLTAGE CHARACTERISTICS  
OF VLA533-01R (TYPICAL)

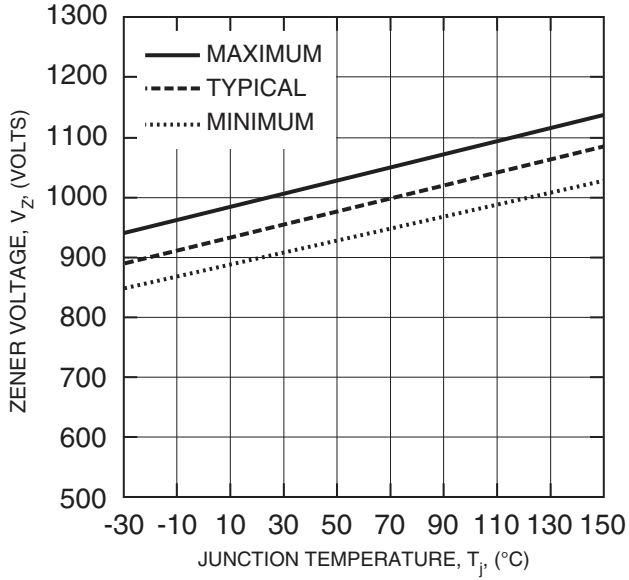

TOTAL ZENER VOLTAGE CHARACTERISTICS  
OF VLA533-02R (TYPICAL)

