



# OV4685 4MP product brief



## High Frame Rate 4-Megapixel Sensor with Excellent Low-Light Sensitivity and OmniHDR-F™ Technology for Security Applications



available in  
a lead-free  
package

The OV4685 is a high performance 4-megapixel CameraChip™ sensor in a native high definition (HD) 16:9 format designed for next-generation surveillance and security systems. The sensor is built on a 2-micron OmniBSI-2™ pixel that provides best-in-class sensitivity, and uses advanced OmniHDR-F™ technology to provide industry leading staggered high dynamic range (HDR).

The 1/3-inch OV4685 can capture full-resolution 4-megapixel HD video at 90 frames per second (fps), 1080p HD at 120 fps, and binned 720p HD at 180 fps. The sensor's high frame rates enable crisp, clean image and video capture of fast moving objects.

The OV4685's advanced OmniHDR-F technology provides staggered HDR timing, increasing dynamic range to 64.6 dB while recording high-quality images and video under extreme variations of bright and dark conditions.

The sensor features a high-speed 4-lane MIPI serial output interface to facilitate the required high data transfer rate. The OV4685 is available in a chip scale package (CSP).

Find out more at [www.ovt.com](http://www.ovt.com).



## Applications

- Security and Surveillance

# OV4685



## Product Features

- automatic black level calibration (ABLC)
- programmable controls for frame rate, mirror and flip, cropping, and windowing
- static defective pixel canceling
- supports output formats: 10-bit RAW RGB (MIPI)
- supports horizontal and vertical subsampling
- supports images sizes: 4MP, 3MP, EIS1080p, 1080p, EIS720p
- fast mode switching
- support 2x2 binning, 4x4 binning, re-sampling filter
- standard serial SCCB interface
- up to 4-lane MIPI serial output interface
- embedded 4K bits one-time programmable (OTP) memory for part identification, etc
- two on-chip phase lock loops (PLLs)
- programmable I/O drive capability
- built-in temperature sensor
- supports staggered, sequential and alternative row HDR timing
- supports staggered 3-exposure HDR mode

## Ordering Information

- OV04685-H67A**  
(color, lead-free, 67-pin CSP5)

## Product Specifications

- active array size:** 2688 x 1520
- max S/N ratio:** 37.8 dB
- power supply:**
  - core: 1.1 - 1.3V
  - analog: 2.6 - 3.0V
  - I/O: 1.7 - 3.0V
- power requirements:**
  - active: 163 mA (261 mW)
  - standby: 1 mA
  - XSHUTDOWN: <10  $\mu$ A
- temperature range:**
  - operating: -30°C to +85°C junction temperature
  - stable image: 0°C to +60°C junction temperature
- output formats:** 10-bit RAW RGB data
- lens size:** 1/3"
- input clock frequency:** 6 - 64 MHz
- lens chief ray angle:** 0°
- dynamic range:** 64.6 dB @ 1x gain
- maximum image transfer rate:**
  - 2688x1520: 90 fps
  - 1920x1080: 120 fps
  - 1280x720: 180 fps
- sensitivity:** 1900 mV/lux-sec
- scan mode:** progressive
- maximum exposure interval:** 1548 x T<sub>ROW</sub>
- pixel size:** 2  $\mu$ m x 2  $\mu$ m
- dark current:** 4 mV/sec @ 60°C junction temperature
- image area:** 5440  $\mu$ m x 3072  $\mu$ m
- package dimensions:** 6630  $\mu$ m x 5830  $\mu$ m

## Functional Block Diagram

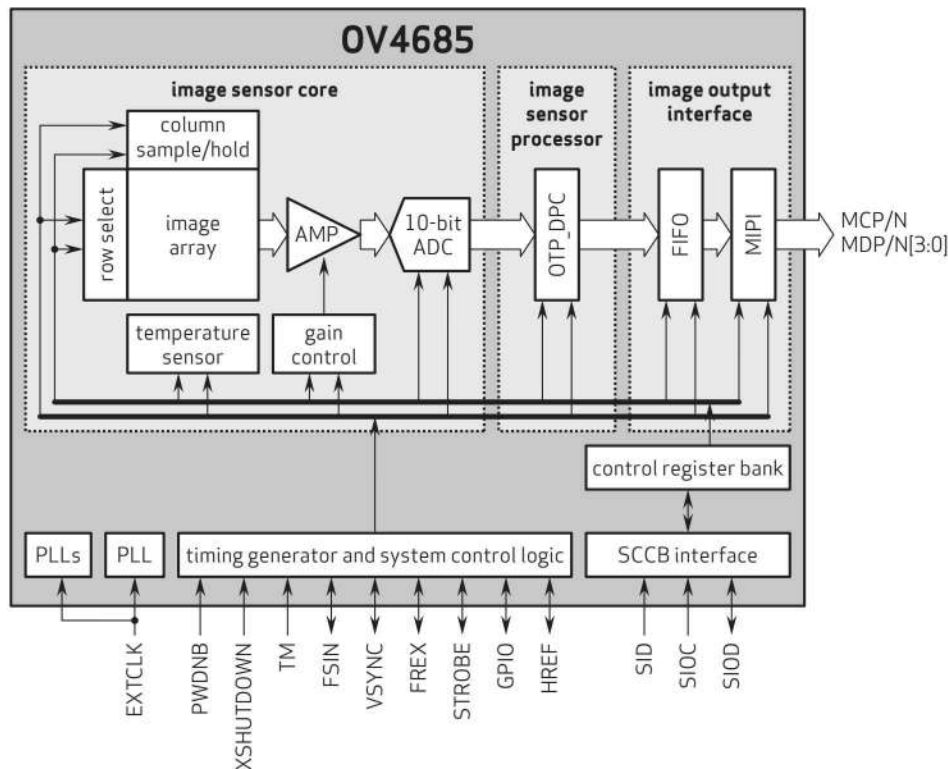

4275 Burton Drive  
Santa Clara, CA 95054  
USA

Tel: +1 408 567 3000  
Fax: +1 408 567 3001  
www.ovt.com

OmniVision reserves the right to make changes to their products or to discontinue any product or service without further notice. OmniVision and the OmniVision logo are registered trademarks of OmniVision Technologies, Inc. CameraChip, OmniBSI-2, OmniBSI+ and OmniBSI are trademarks of OmniVision Technologies, Inc. All other trademarks are the property of their respective owners.



OmniVision