

4 mm Square Double-action SMD Light Touch Switches

Type: **EVPAH**

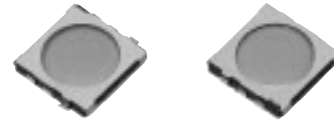

■ Features

- External dimensions : 4.0 mm×4.1 mm, Height 0.59 mm
- Long operation life
- Wide selection of double action operating variations

■ Recommended Applications

- Camera function (Digital still cameras, Camcorders, Mobile phones, etc.) for shutter switches.

■ Explanation of Part Numbers

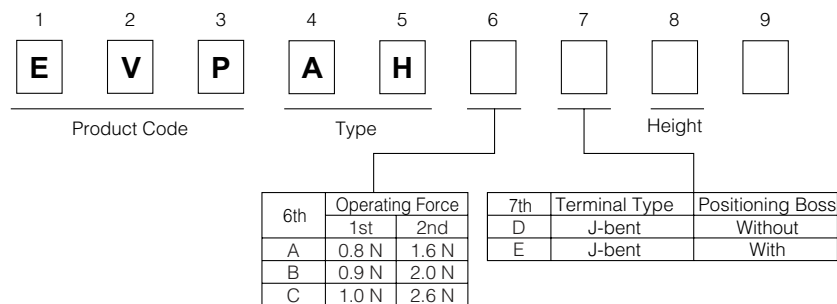

■ Specifications

Type		Snap action/Push-on type SPDT
Electrical	Rating	10 μ A 2 Vdc to 20 mA 15 Vdc (Resistive load)
	Contact Resistance	500 m Ω max.
	Insulation Resistance	100 M Ω min. (at 100 Vdc)
	Dielectric Withstanding Voltage	250 Vac for 1 minute
	Bouncing	20 ms max. (ON, OFF)
Mechanical	Operating Force	1st : 0.8 N, 0.9 N, 1.0 N 2nd : 1.6 N, 2.0 N, 2.6 N
	Travel	1st: 0.15 mm 2nd: 0.3 mm
Endurance	Operating Life	1.6 N : 100000 cycles min. 2.0 N : 100000 cycles min. 2.6 N : 30000 cycles min.
Operating Temperature		-20 °C to +70 °C
Storage Temperature		-40 °C to +85 °C (Bulk) -20 °C to +60 °C (Taping)
Minimum Quantity/Packing Unit		8000 pcs. Embossed Taping (Reel Pack)
Quantity/Carton		40000 pcs.

NEW

■ Dimensions in mm (not to scale)

EVPAH

With J-bent terminals

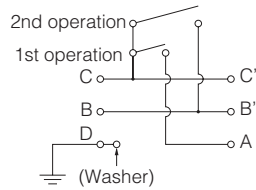
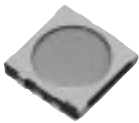
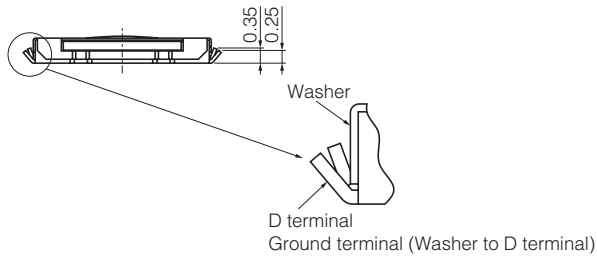
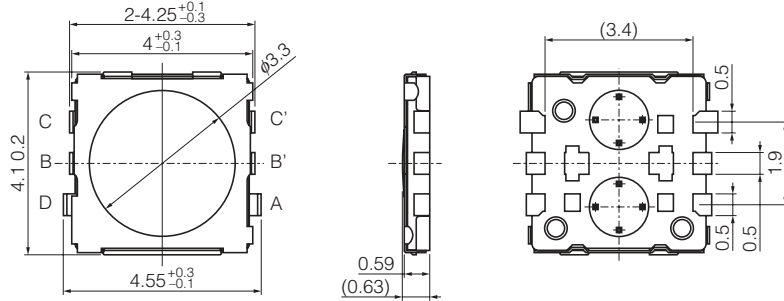

Circuit Diagram

* C or/and C' shall be used as common/ground terminal.

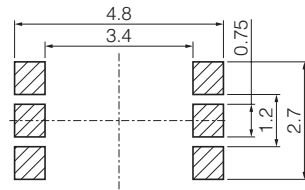

PWB land pattern for reference (View from mounting side)

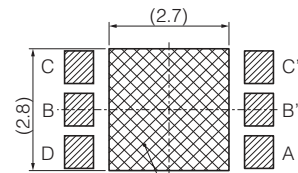

Please do not Provide any Land pattern in this area.

Part Numbers	Boss	Ground Terminal	Operating Force		Height	Operating Life
			1 th	2 th		
EVPAHAD6A	Without	With	0.8 N	1.6 N	0.59	100000 cycles
EVPAHBD6A	Without	With	0.9 N	2.0 N	0.59	100000 cycles
EVPAHCD6A	Without	With	1.0 N	2.6 N	0.59	30000 cycles

Design and specifications are each subject to change without notice. Ask factory for the current technical specifications before purchase and/or use. Should a safety concern arise regarding this product, please be sure to contact us immediately.

Recommended Reflow Soldering Conditions

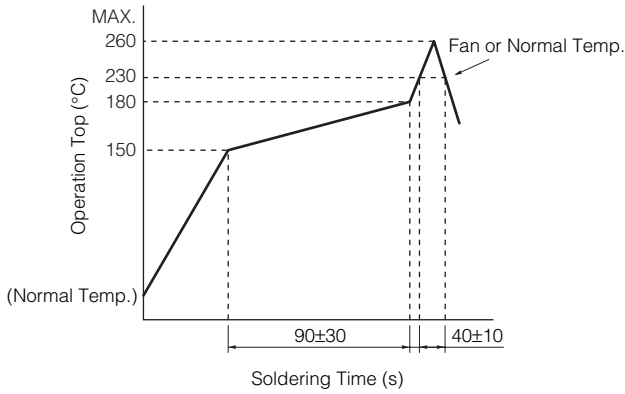

Embossed Carrier Taping

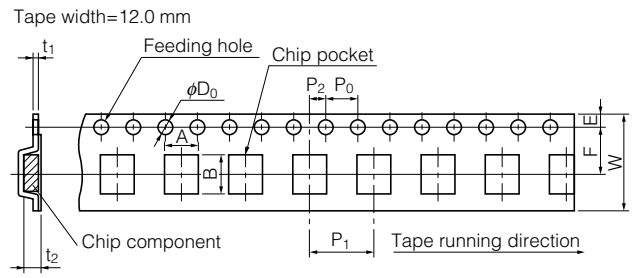

Unit: mm

Part No.	Height	A	B	W	F	E	P ₁	P ₂	P ₀	D ₀ Dia.	t ₁	t ₂
EVPAH	0.59	4.36±0.2	4.4±0.2	12.0 ^{+0.3} _{-0.1}	5.5±0.1	1.75±0.1	8.0±0.1	2.0±0.1	4.0±0.1	1.5 ^{+0.1} _{-0.1}	0.3±0.05	1.25 ^{+0.2} _{-0.1}

Standard Reel Dimensions in mm (not to scale)

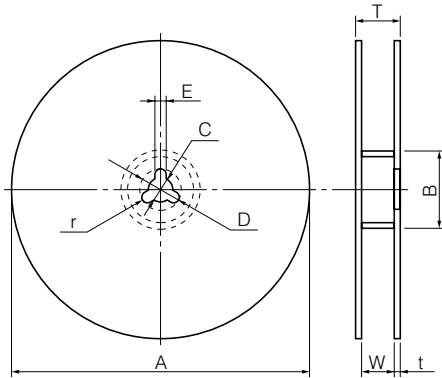

Item	A	B	C	D	E
Rate (mm)	φ380.0±2.0	φ80.0±1.0	φ13.0±0.5	φ21.0±1.0	2.0±0.5

Item	W	T	t	r
Rate (mm)	13.5±1.0	17.5±1.0	1.0 to 3.0	1.0±0.5

Recommended Shape of Test Pole

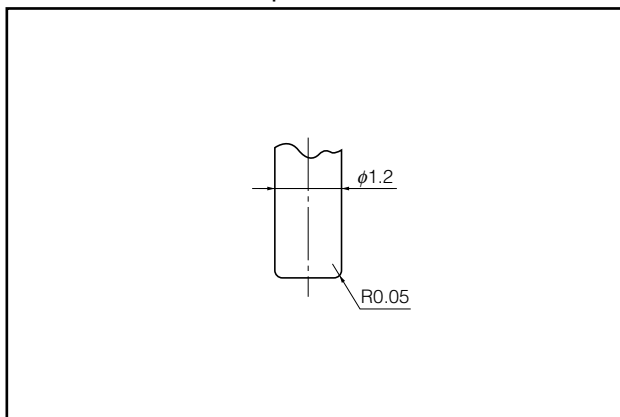

Recommended Operating Conditions

