

THIS DRAWING IS UNPUBLISHED. RELEASED FOR PUBLICATION 20
 © COPYRIGHT 20 BY TYCO ELECTRONICS CORPORATION. ALL RIGHTS RESERVED.

LOC	DIST	REVISIONS					
CE	00	P	LTR	DESCRIPTION	DATE	DWN	APVD
		G		REV PER ECN 0A00-0287-04	08JUN2004	DEH	SAB
		H		REVISE PER ECR-05-010753	12SEPT2005	BB	SB

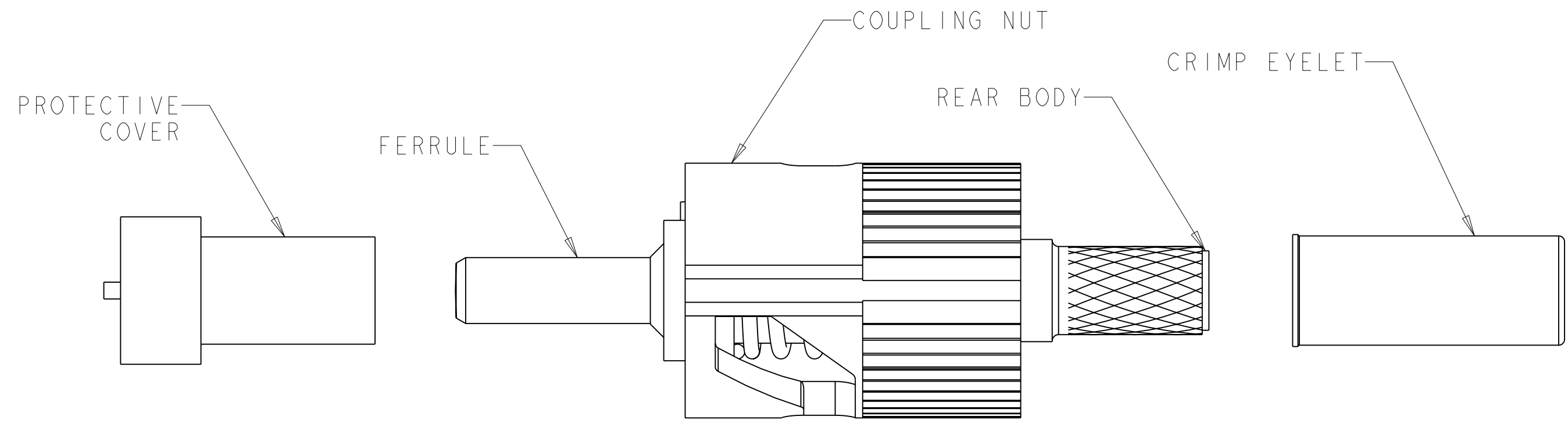

△ MATERIAL:
 PROTECTIVE COVER: LDPE, COLOR: BLACK, NON-FR
 CONNECTOR ASSEMBLY:
 COUPLING NUT: SEE TABLE
 FERRULE ASSEMBLY: CERAMIC/ARP-GF30, COLOR: BLACK*
 SPRING: STAINLESS STEEL
 RETENTION RING: STAINLESS STEEL
 CRIMP EYELET: TIN PLATED COPPER
 *UL94 V-0 RATED AT QUALIFYING THICKNESS.

2. BULK PACKAGED

-	ZINC	125±2µm	503676-5
-	POLYMER	125±2µm	503676-4
I	ZINC	125±2µm	503676-1
CRIMP EYELET	COUPLING NUT	FIBER SIZE	PART NUMBER

<small>THIS DRAWING IS A CONTROLLED DOCUMENT FOR TYCO ELECTRONICS CORPORATION IT IS SUBJECT TO CHANGE AND THE CONTROLLING ENGINEERING ORGANIZATION SHOULD BE CONTACTED FOR THE LATEST REVISION.</small>		DWN D E HODGE 08JUN04 CHK E. HOPKINS 08JUN04 APVD S. BUCHTER 08JUN04	tyco Tyco Electronics Electronics Harrisburg, PA 17105-3608
DIMENSIONS: INCHES	TOLERANCES UNLESS OTHERWISE SPECIFIED: 0 PLC ± 1 PLC ± 2 PLC ± 3 PLC ± 4 PLC ± ANGLES ±	PRODUCT SPEC - APPLICATION SPEC - WEIGHT -	NAME KIT, CONNECTOR, OVERMOLDED CERAMIC MULTIMODE, BAYONET
MATERIAL △ -	FINISH -	SIZE A2	CAGE CODE 00779
CUSTOMER DRAWING		DRAWING NO C=503676	RESTRICTED TO -
		SCALE 6:1	SHEET 1 OF 1 REV H