

Ranging and gesture detection sensor expansion board based on VL53L0X for STM32 Nucleo

Data brief

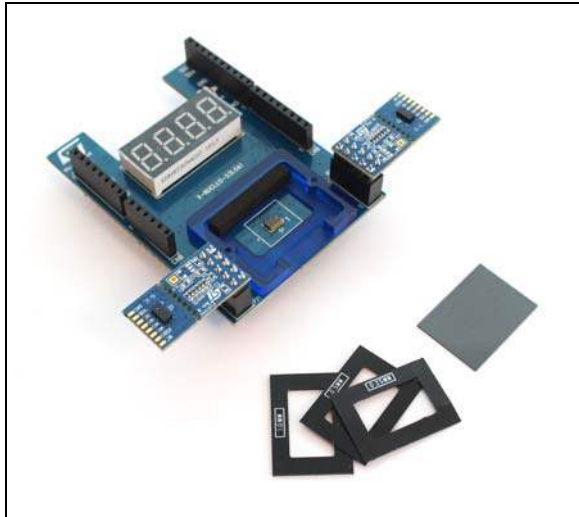

Features

- VL53L0X ranging and gesture detection sensor module.
- Accurate absolute ranging distance, independent of the reflectance of the target.
- 4-digit display, displaying the distance of a target from the ranging sensor.
- Basic gesture recognition application can be developed with a VL53L0X module.
- 0.25, 0.5 and 1mm spacers to simulate air gaps
- Cover glass
- Two VL53L0X satellite boards
- Two 10 pin connectors for VL53L0X satellite boards
- Compatible with STM32 Nucleo board family.
- Equipped with Arduino™ UNO R3 connector.
- RoHS compliant.
- Full system SW supplied, download from www.st.com/VL53L0X.

Description

The X-NUCLEO-53L0A1 expansion board features the VL53L0X ranging and gesture detection sensor, based on ST's FlightSense™, Time-of-Flight technology.

It is an evaluation board that provides an introduction to the ranging and gesture detection capabilities of the VL53L0X module.

To allow the user to validate the VL53L0X in an environment as close as possible to its final application, the X-NUCLEO-53L0A1 expansion board is delivered with a cover glass holder in which 3 different spacers of 0.25, 0.5 and 1mm height can be fitted below the cover glass in order to simulate various air gaps.

Two VL53L0X satellites can be connected using the two 10 pin connectors.

The expansion board is compatible with the STM32 Nucleo board family, and with the Arduino UNO R3 connector layout.

Several ST expansion boards can be superposed through the Arduino connectors, which allows, for example, to develop VL53L0X applications with Bluetooth or Wi-Fi interface.

Table 1. Ordering information

Order code	Description
X-NUCLEO-53L0A1	Expansion board for STM32 Nucleo board family.

1 Block diagram

Figure 1 describes X-NUCLEO-53L0A1 expansion board features.

Figure 1. X-NUCLEO-53L0A1 expansion board block diagram

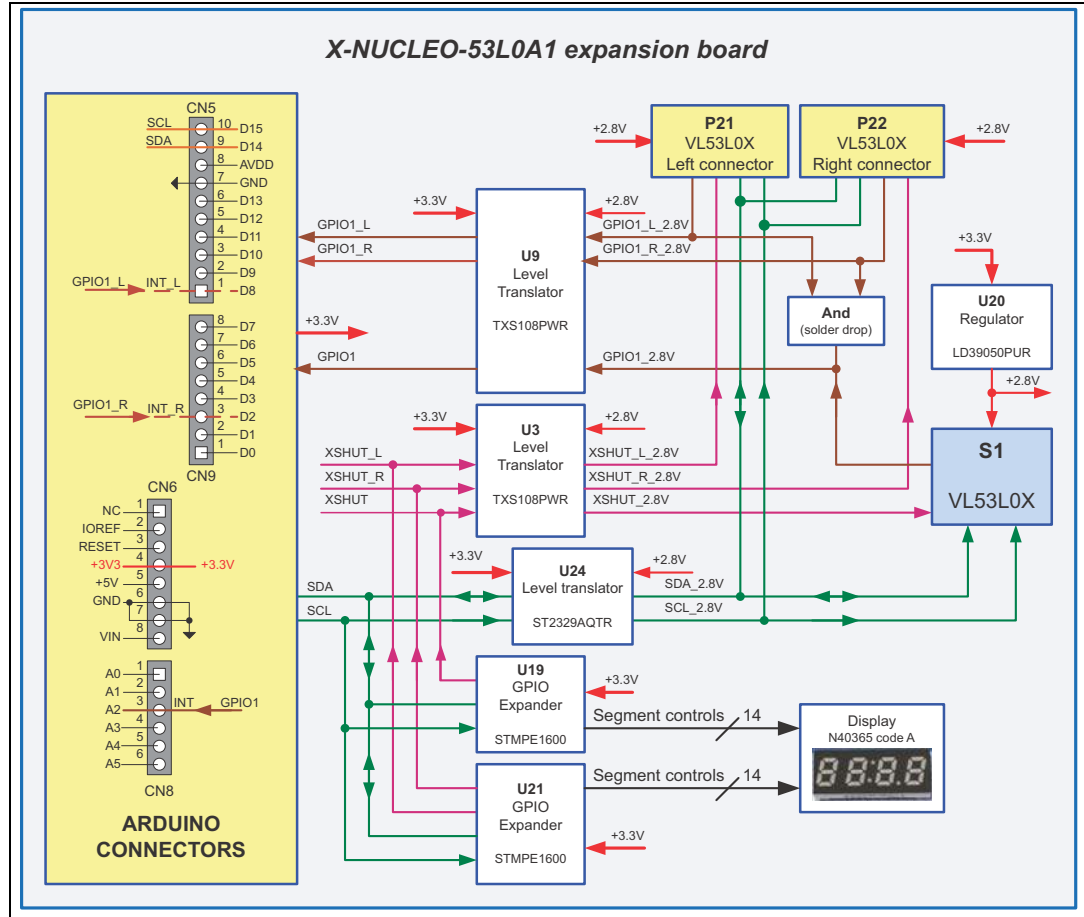

2 Optional VL53L0X satellite board

The VL53L0X satellites can be directly plugged onto the VL53L0X expansion board through the two 10 pin connectors or connected to the board through flying leads.

When connected through flying leads, developers should break off the mini PCB from the satellite board, and use only the “VL53L0X mini PCB” which benefits from a smaller form factor for an easier integration into customers devices.

Figure 2. Connections of VL53L0X satellite boards

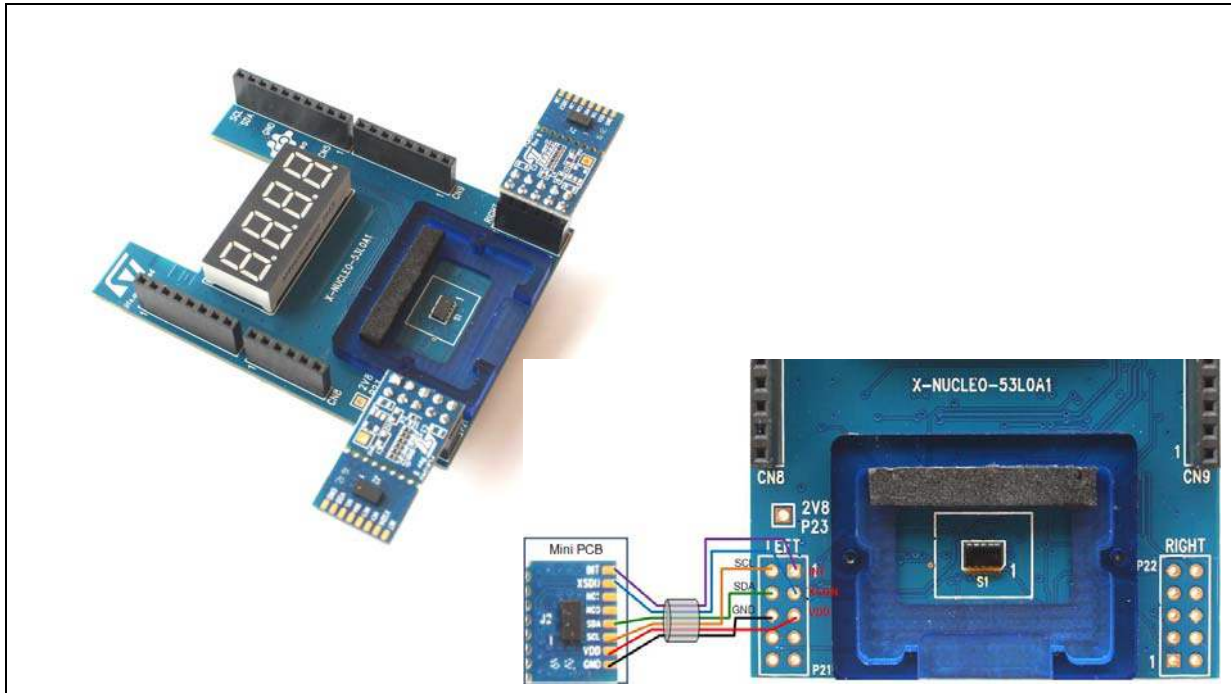

3 Laser consideration

The VL53L0X contains a laser emitter and corresponding drive circuitry. The laser output is designed to remain within Class 1 laser safety limits under all reasonably foreseeable conditions including single faults in compliance with IEC 60825-1:2014 Edition 3. The laser output will remain within Class 1 limits as long as the STMicroelectronics recommended device settings are used and the operating conditions specified in the datasheet are respected. The laser output power must not be increased by any means and no optics should be used with the intention of focusing the laser beam.

Figure 3. Class 1 laser product label



4 ECOPACK®

In order to meet environmental requirements, ST offers these devices in different grades of ECOPACK® packages, depending on their level of environmental compliance. ECOPACK® specifications, grade definitions and product status are available at: www.st.com. ECOPACK® is an ST trademark.

5 Revision history

Table 2. Document revision history

Date	Revision	Changes
13-May-2016	1	Initial release.
21-Jul-2016	2	Change the figure in the first page

IMPORTANT NOTICE – PLEASE READ CAREFULLY

STMicroelectronics NV and its subsidiaries ("ST") reserve the right to make changes, corrections, enhancements, modifications, and improvements to ST products and/or to this document at any time without notice. Purchasers should obtain the latest relevant information on ST products before placing orders. ST products are sold pursuant to ST's terms and conditions of sale in place at the time of order acknowledgement.

Purchasers are solely responsible for the choice, selection, and use of ST products and ST assumes no liability for application assistance or the design of Purchasers' products.

No license, express or implied, to any intellectual property right is granted by ST herein.

Resale of ST products with provisions different from the information set forth herein shall void any warranty granted by ST for such product.

ST and the ST logo are trademarks of ST. All other product or service names are the property of their respective owners.

Information in this document supersedes and replaces information previously supplied in any prior versions of this document.

© 2016 STMicroelectronics – All rights reserved

