

Features

- ◆ High-speed access
 - Commercial: 20/35/55/100ns (max.)
 - Industrial: 25/55ns (max.)
 - Military: 25/35/55/100ns (max.)
- ◆ Low-power operation
 - IDT7132/42SA
Active: 325mW (typ.)
Standby: 5mW (typ.)
 - IDT7132/42LA
Active: 325mW (typ.)
Standby: 1mW (typ.)
- ◆ MASTER IDT7132 easily expands databus width to 16-or-more bits using SLAVE IDT7142
- ◆ On-chip port arbitration logic (IDT7132 only)
- ◆ **BUSY** output flag on IDT7132; **BUSY** input on IDT7142
- ◆ Battery backup operation —2V data retention (LA only)
- ◆ TTL-compatible, single 5V ±10% power supply
- ◆ Available in 48-pin DIP, LCC and Flatpack, and 52-pin PLCC packages
- ◆ Military product compliant to MIL-PRF-38535 QML
- ◆ Industrial temperature range (-40°C to +85°C) is available for selected speeds
- ◆ Green parts available, see ordering information

Functional Block Diagram

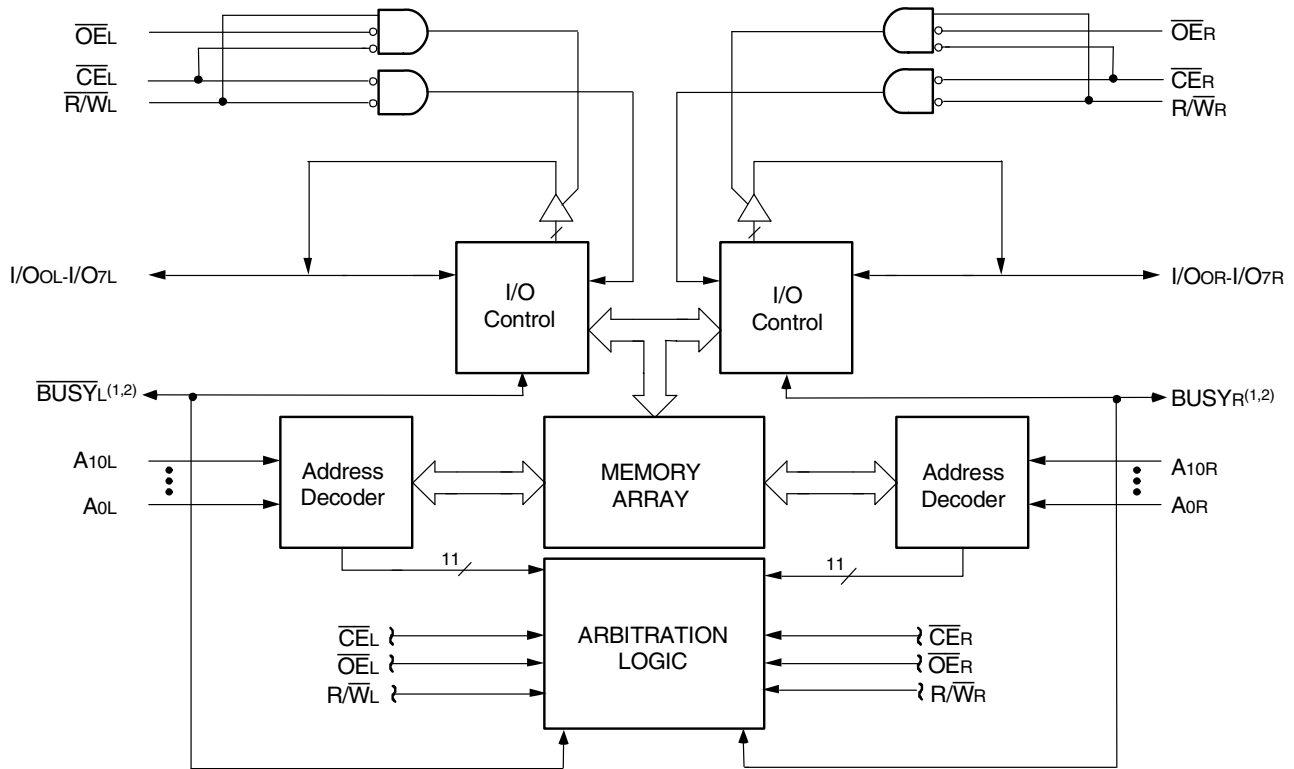

2692 drw 01

NOTES:

1. IDT7132 (MASTER): $\overline{\text{BUSY}}$ is open drain output and requires pullup resistor of 270Ω.
IDT7142 (SLAVE): $\overline{\text{BUSY}}$ is input.
2. Open drain output: requires pullup resistor of 270Ω.

Description

The IDT7132/IDT7142 are high-speed 2K x 8 Dual-Port Static RAMs. The IDT7132 is designed to be used as a stand-alone 8-bit Dual-Port RAM or as a "MASTER" Dual-Port RAM together with the IDT7142 "SLAVE" Dual-Port in 16-bit-or-more word width systems. Using the IDT MASTER/SLAVE Dual-Port RAM approach in 16-or-more-bit memory system applications results in full-speed, error-free operation without the need for additional discrete logic.

Both devices provide two independent ports with separate control, address, and I/O pins that permit independent, asynchronous access for reads or writes to any location in memory. An automatic power down feature, controlled by \overline{CE} permits the on-chip circuitry of each port to enter

a very low standby power mode.

Fabricated using CMOS high-performance technology, these devices typically operate on only 325mW of power. Low-power (LA) versions offer battery backup data retention capability, with each Dual-Port typically consuming 200 μ W from a 2V battery.

The IDT7132/7142 devices are packaged in a 48-pin sidebraze or plastic DIPs, 48-pin LCCs, 52-pin PLCCs, and 48-lead flatpacks. Military grade product is manufactured in compliance with the latest revision of MIL-PRF-38535 QML, making it ideally suited to military temperature applications demanding the highest level of performance and reliability.

Pin Configurations (1,2,3)

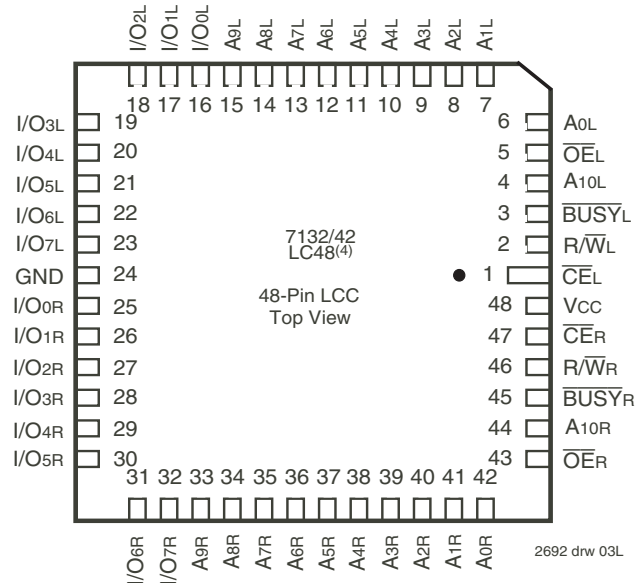
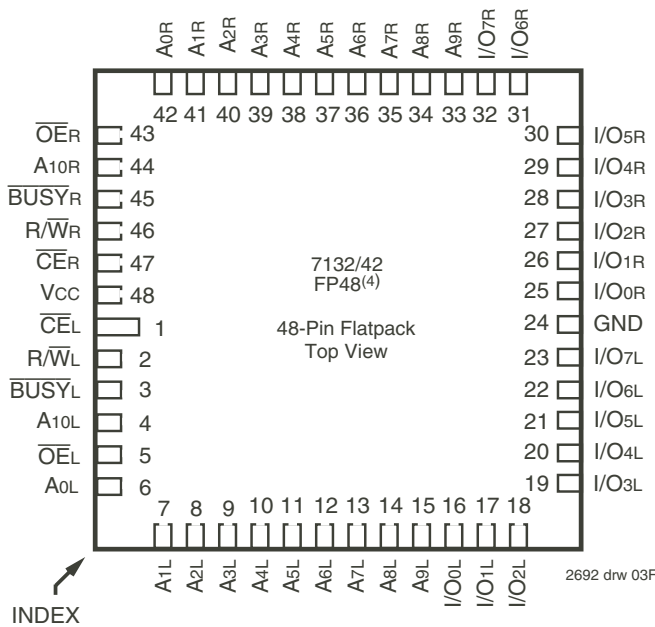

NOTES:

1. All Vcc pins must be connected to the power supply.
2. All GND pins must be connected to the ground supply.
3. LC48 package body is approximately .57 in x .57 in x .68 in.
FP48 package body is approximately .75 in x .75 in x .11 in.
4. This package code is used to reference the package diagram.

Pin Configurations^(1,2,3) (con't.)

\overline{CE}_L	1	●	48	VCC
R/W $_L$	2		47	\overline{CE}_R
BUSY $_L$	3		46	R/W $_R$
A $_{10L}$	4	7132	45	BUSY $_R$
\overline{OE}_L	5	7142	44	A $_{10R}$
A $_0L$	6		43	\overline{OE}_R
A $_1L$	7	PDG48 ⁽⁴⁾	42	A $_0R$
A $_2L$	8	or	41	A $_1R$
A $_3L$	9	SB48 ⁽⁴⁾	40	A $_2R$
A $_4L$	10		39	A $_3R$
A $_5L$	11		38	A $_4R$
A $_6L$	12	48-Pin	37	A $_5R$
A $_7L$	13	DIP	36	A $_6R$
A $_8L$	14	Top	35	A $_7R$
A $_9L$	15	View ⁽⁵⁾	34	A $_8R$
I/O $_0L$	16		33	A $_9R$
I/O $_1L$	17		32	I/O $_7R$
I/O $_2L$	18		31	I/O $_6R$
I/O $_3L$	19		30	I/O $_5R$
I/O $_4L$	20		29	I/O $_4R$
I/O $_5L$	21		28	I/O $_3R$
I/O $_6L$	22		27	I/O $_2R$
I/O $_7L$	23		26	I/O $_1R$
GND	24		25	I/O $_0R$

NOTES:

1. All Vcc pins must be connected to the power supply.
2. All GND pins must be connected to the ground supply.
3. PDG48 package body is approximately .55 in x 2.43 in x .18 in.
SB48 package body is approximately .62 in x 2.43 in x .15 in.
4. This package code is used to reference the package diagram.
5. This text does not indicate orientation of the actual part-marking.

2692 drw 02a

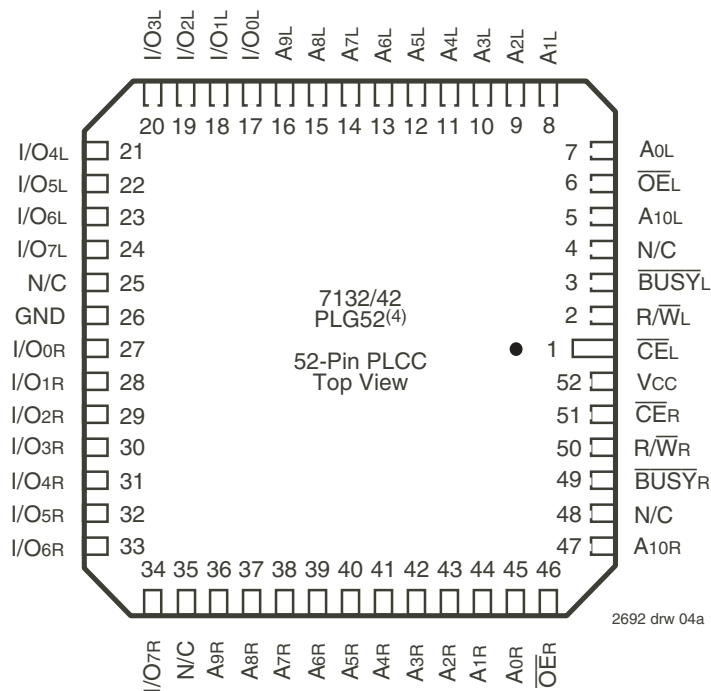

2692 drw 04a

NOTES:

1. All Vcc pins must be connected to the power supply.
2. All GND pins must be connected to the ground supply.
3. PLG52 package body is approximately .75 in x .75 in x .17 in.
4. This package code is used to reference the package diagram.

Recommended Operating Temperature and Supply Voltage^(1,2)

Grade	Ambient Temperature	GND	V _{cc}
Military	-55°C to +125°C	0V	5.0V ± 10%
Commercial	0°C to +70°C	0V	5.0V ± 10%
Industrial	-40°C to +85°C	0V	5.0V ± 10%

2692 tbl 02

NOTES:

1. This is the parameter T_A. This is the "instant on" case temperature.
2. Industrial temperature: for specific speeds, packages and powers contact your sales office.

Recommended DC Operating Conditions

Symbol	Parameter	Min.	Typ.	Max.	Unit
V _{cc}	Supply Voltage	4.5	5.0	5.5	V
GND	Ground	0	0	0	V
V _{IH}	Input High Voltage	2.2	—	6.0 ⁽²⁾	V
V _{IL}	Input Low Voltage	-0.5 ⁽¹⁾	—	0.8	V

2692 tbl 03

NOTES:

1. V_{IL} (min.) = -1.5V for pulse width less than 10ns.
2. V_{TERM} must not exceed V_{cc} + 10%.

Absolute Maximum Ratings⁽¹⁾

Symbol	Rating	Commercial & Industrial	Military	Unit
V _{TERM} ⁽²⁾	Terminal Voltage with Respect to GND	-0.5 to +7.0	-0.5 to +7.0	V
T _{BIAS}	Temperature Under Bias	-55 to +125	-65 to +135	°C
T _{STG}	Storage Temperature	-65 to +150	-65 to +150	°C
I _{OUT}	DC Output Current	50	50	mA

2692 tbl 01

NOTES:

1. Stresses greater than those listed under ABSOLUTE MAXIMUM RATINGS may cause permanent damage to the device. This is a stress rating only and functional operation of the device at these or any other conditions above those indicated in the operational sections of the specification is not implied. Exposure to absolute maximum rating conditions for extended periods may affect reliability.
2. V_{TERM} must not exceed V_{cc} + 10% for more than 25% of the cycle time or 10ns maximum, and is limited to ≤ 20mA for the period of V_{TERM} ≥ V_{cc} + 10%.

Capacitance⁽¹⁾ (T_A = +25°C, f = 1.0MHz)

Symbol	Parameter	Conditions ⁽²⁾	Max.	Unit
C _{IN}	Input Capacitance	V _{IN} = 3dV	11	pF
C _{OUT}	Output Capacitance	V _{OUT} = 3dV	11	pF

2692 tbl 00

NOTES:

1. This parameter is determined by device characterization but is not production tested.
2. 3dV represents the interpolated capacitance when the input and output signals switch from 3V to 0V.

DC Electrical Characteristics Over the Operating Temperature and Supply Voltage Range^(1,5,8) (V_{CC} = 5.0V ± 10%)

Symbol	Parameter	Test Condition	Version	7132X20 ⁽²⁾ 7142X20 ⁽²⁾ Com'l Only		7132X25 ⁽⁷⁾ 7142X25 ⁽⁷⁾ Com'l, Ind & Military		7132X35 7142X35 Com'l & Military		Unit	
				Typ.	Max.	Typ.	Max.	Typ.	Max.		
I _{CC}	Dynamic Operating Current (Both Ports Active)	$\overline{CE}_L = \overline{CE}_R = V_{IL}$, Outputs Disabled $f = f_{MAX}^{(3)}$	COM'L	SA	110	250	110	220	80	165	mA
				LA	110	200	110	170	80	120	
			MIL & IND	SA	—	—	110	280	80	230	
				LA	—	—	110	220	80	170	
I _{SB1}	Standby Current (Both Ports - TTL Level Inputs)	$\overline{CE}_L = \overline{CE}_R = V_{IH}$, $f = f_{MAX}^{(3)}$	COM'L	SA	30	65	30	65	25	65	mA
				LA	30	45	30	45	25	45	
			MIL & IND	SA	—	—	30	80	25	80	
				LA	—	—	30	60	25	60	
I _{SB2}	Standby Current (One Port - TTL Level Inputs)	$\overline{CE}^*A = V_{IL}$ and $\overline{CE}^*B = V_{IH}^{(6)}$ Active Port Outputs Disabled $f = f_{MAX}^{(3)}$	COM'L	SA	65	165	65	150	50	125	mA
				LA	65	125	65	115	50	90	
			MIL & IND	SA	—	—	65	160	50	150	
				LA	—	—	65	125	50	115	
I _{SB3}	Full Standby Current (Both Ports - All CMOS Level Inputs)	\overline{CE}_L and $\overline{CE}_R \geq V_{CC} - 0.2V$ $V_{IN} \geq V_{CC} - 0.2V$ or $V_{IN} \leq 0.2V$, $f = 0^{(4)}$	COM'L	SA	1.0	15	1.0	15	1.0	15	mA
				LA	0.2	5	0.2	5	0.2	4	
			MIL & IND	SA	—	—	1.0	30	1.0	30	
				LA	—	—	0.2	10	0.2	10	
I _{SB4}	Full Standby Current (One Port - All CMOS Level Inputs)	$\overline{CE}^*A \leq 0.2V$ and $\overline{CE}^*B \geq V_{CC} - 0.2V^{(6)}$ $V_{IN} \geq V_{CC} - 0.2V$ or $V_{IN} \leq 0.2V$ Active Port Outputs Disabled $f = f_{MAX}^{(3)}$	COM'L	SA	60	155	60	145	45	110	mA
				LA	60	115	60	105	45	85	
			MIL & IND	SA	—	—	60	155	45	145	
				LA	—	—	60	115	45	105	

2692 tbl 04a

Symbol	Parameter	Test Condition	Version	7132X55 7142X55 Com'l & Military		7132X100 7142X100 Com'l & Military		Unit	
				Typ.	Max.	Typ.	Max.		
I _{CC}	Dynamic Operating Current (Both Ports Active)	$\overline{CE}_L = \overline{CE}_R = V_{IL}$, Outputs Disabled $f = f_{MAX}^{(3)}$	COM'L	SA	65	155	65	155	mA
				LA	65	110	65	110	
			MIL & IND	SA	65	190	65	190	
				LA	65	140	65	140	
I _{SB1}	Standby Current (Both Ports - TTL Level Inputs)	$\overline{CE}_L = \overline{CE}_R = V_{IH}$, $f = f_{MAX}^{(3)}$	COM'L	SA	20	65	20	55	mA
				LA	20	35	20	35	
			MIL & IND	SA	20	65	20	65	
				LA	20	45	20	45	
I _{SB2}	Standby Current (One Port - TTL Level Inputs)	$\overline{CE}^*A = V_{IL}$ and $\overline{CE}^*B = V_{IH}^{(6)}$ Active Port Outputs Disabled $f = f_{MAX}^{(3)}$	COM'L	SA	40	110	40	110	mA
				LA	40	75	40	75	
			MIL & IND	SA	40	125	40	125	
				LA	40	90	40	90	
I _{SB3}	Full Standby Current (Both Ports - All CMOS Level Inputs)	\overline{CE}_L and $\overline{CE}_R \geq V_{CC} - 0.2V$ $V_{IN} \geq V_{CC} - 0.2V$ or $V_{IN} \leq 0.2V$, $f = 0^{(4)}$	COM'L	SA	1.0	15	1.0	15	mA
				LA	0.2	4	0.2	4	
			MIL & IND	SA	1.0	30	1.0	30	
				LA	0.2	10	0.2	10	
I _{SB4}	Full Standby Current (One Port - All CMOS Level Inputs)	$\overline{CE}^*A \leq 0.2V$ and $\overline{CE}^*B \geq V_{CC} - 0.2V^{(6)}$ $V_{IN} \geq V_{CC} - 0.2V$ or $V_{IN} \leq 0.2V$ Active Port Outputs Disabled $f = f_{MAX}^{(3)}$	COM'L	SA	40	100	40	95	mA
				LA	40	70	40	70	
			MIL & IND	SA	40	110	40	110	
				LA	40	85	40	80	

2692 tbl 04b

NOTES:

- 'X' in part numbers indicates power rating (SA or LA).
- PLCC Package only
- At $f = f_{MAX}$, address and control lines (except Output Enable) are cycling at the maximum frequency read cycle of $1/t_{rc}$, and using "AC TEST CONDITIONS" of input levels of GND to 3V.
- $f = 0$ means no address or control lines change. Applies only to inputs at CMOS level standby.
- $V_{CC} = 5V$, $T_A = +25^\circ C$ for Typ and is not production tested. $V_{CC DC} = 100mA$ (Typ)
- Port "A" may be either left or right port. Port "B" is opposite from port "A".
- Not available in DIP packages.
- Industrial temperature: for specific speeds, packages and powers contact your sales office.

DC Electrical Characteristics Over the Operating Temperature Supply Voltage Range ($V_{CC} = 5.0V \pm 10\%$)

Symbol	Parameter	Test Conditions	7132SA 7142SA		7132LA 7142LA		Unit
			Min.	Max.	Min.	Max.	
$ I_{LI} $	Input Leakage Current ⁽¹⁾	$V_{CC} = 5.5V$, $V_{IN} = 0V$ to V_{CC}	—	10	—	5	μA
$ I_{LO} $	Output Leakage Current	$V_{CC} = 5.5V$, $\overline{CE} = V_{IH}$, $V_{OUT} = 0V$ to V_{CC}	—	10	—	5	μA
V_{OL}	Output Low Voltage	$I_{OL} = 4mA$	—	0.4	—	0.4	V
V_{OL}	Open Drain Output Low Voltage (BUSY)	$I_{OL} = 16mA$	—	0.5	—	0.5	V
V_{OH}	Output High Voltage	$I_{OH} = -4mA$	2.4	—	2.4	—	V

2692 tbl 05

NOTE:

- At $V_{CC} \leq 2.0V$ leakages are undefined.

Data Retention Characteristics (LA Version Only)

Symbol	Parameter	Test Condition	Min.	Typ. ⁽¹⁾	Max.	Unit	
V_{DR}	V_{CC} for Data Retention	$V_{CC} = 2.0V$	2.0	—	—	V	
I_{CCDR}	Data Retention Current	$\overline{CE} \geq V_{CC} - 0.2V$ $V_{IN} \geq V_{CC} - 0.2V$ or $V_{IN} \leq 0.2V$	Mil. & Ind.	—	100	4000	μA
			Com'l.	—	100	1500	μA
$t_{CDR}^{(3)}$	Chip Deselect to Data Retention Time	$V_{IN} \leq 0.2V$	0	—	—	ns	
$t_R^{(3)}$	Operation Recovery Time		$t_{RC}^{(2)}$	—	—	ns	

2692 tbl 06

NOTES:

- $V_{CC} = 2V$, $T_A = +25^\circ C$, and is not production tested.
- t_{RC} = Read Cycle Time
- This parameter is guaranteed but not production tested.

Data Retention Waveform

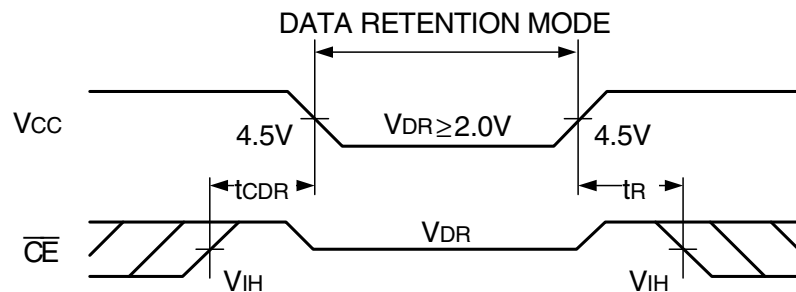

2692 drw 05

AC Test Conditions

Input Pulse Levels	GND to 3.0V
Input Rise/Fall Times	3ns Max.
Input Timing Reference Levels	1.5V
Output Reference Levels	1.5V
Output Load	Figures 1, 2, and 3

2692 tbl 07

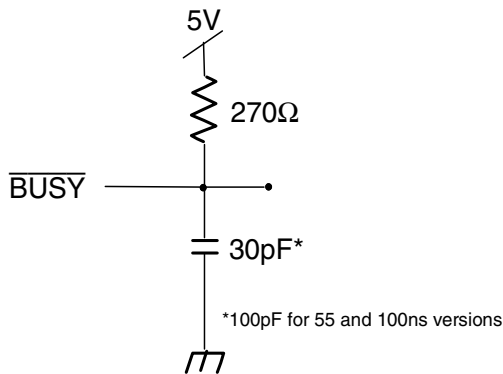
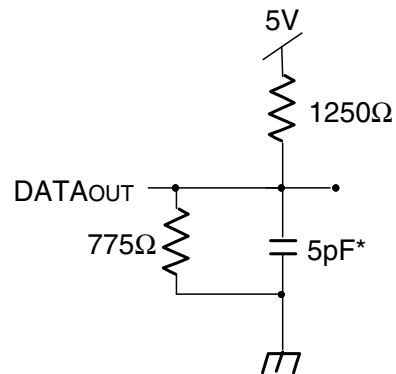
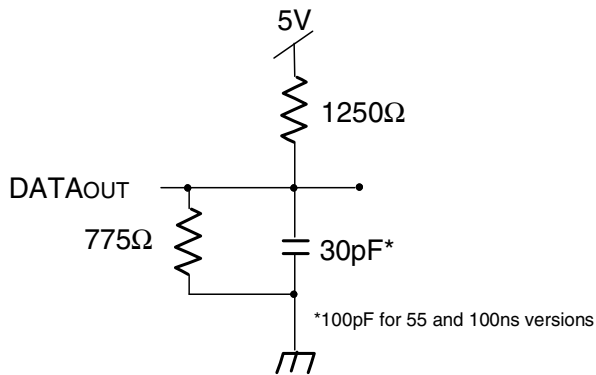

2692 drw 06

AC Electrical Characteristics Over the Operating Temperature and Supply Voltage Range^(3,5)

Symbol	Parameter	7132X20 ⁽²⁾ 7142X20 ⁽²⁾ Com'l Only		7132X25 ⁽²⁾ 7142X25 ⁽²⁾ Com'l, Ind & Military		7132X35 7142X35 Com'l & Military		Unit
		Min.	Max.	Min.	Max.	Min.	Max.	
READ CYCLE								
t _{RC}	Read Cycle Time	20	—	25	—	35	—	ns
t _{AA}	Address Access Time	—	20	—	25	—	35	ns
t _{ACE}	Chip Enable Access Time	—	20	—	25	—	35	ns
t _{AOE}	Output Enable Access Time	—	11	—	12	—	20	ns
t _{OH}	Output Hold from Address Change	3	—	3	—	3	—	ns
t _{LZ}	Output Low-Z Time ^(1,4)	0	—	0	—	0	—	ns
t _{HZ}	Output High-Z Time ^(1,4)	—	10	—	10	—	15	ns
t _{PU}	Chip Enable to Power Up Time ⁽⁴⁾	0	—	0	—	0	—	ns
t _{PD}	Chip Disable to Power Down Time ⁽⁴⁾	—	20	—	25	—	35	ns

2692 tbl 08a

Symbol	Parameter	7132X55 7142X55 Com'l & Military		7132X100 7142X100 Com'l & Military		Unit
		Min.	Max.	Min.	Max.	
READ CYCLE						
t _{RC}	Read Cycle Time	55	—	100	—	ns
t _{AA}	Address Access Time	—	55	—	100	ns
t _{ACE}	Chip Enable Access Time	—	55	—	100	ns
t _{AOE}	Output Enable Access Time	—	25	—	40	ns
t _{OH}	Output Hold from Address Change	3	—	10	—	ns
t _{LZ}	Output Low-Z Time ^(1,4)	5	—	5	—	ns
t _{HZ}	Output High-Z Time ^(1,4)	—	25	—	40	ns
t _{PU}	Chip Enable to Power Up Time ⁽⁴⁾	0	—	0	—	ns
t _{PD}	Chip Disable to Power Down Time ⁽⁴⁾	—	50	—	50	ns

2692 tbl 08b

NOTES:

1. Transition is measured 0mV from Low or High-Impedance Voltage Output Test Load (Figure 2).
2. PLCC package only.
3. 'X' in part numbers indicates power rating (SA or LA).
4. This parameter is guaranteed by device characterization, but is not production tested.
5. Industrial temperature: for specific speeds, packages and powers contact your sales office.

Timing Waveform of Read Cycle No. 1, Either Side⁽¹⁾

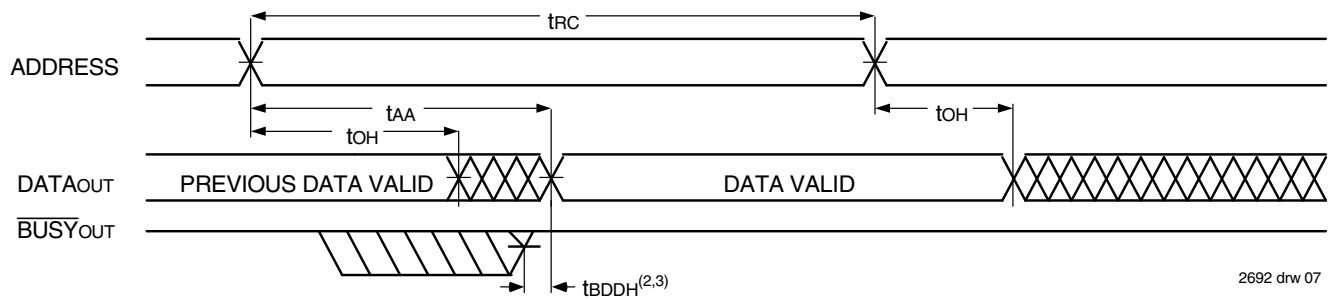

Timing Waveform of Read Cycle No. 2, Either Side⁽¹⁾

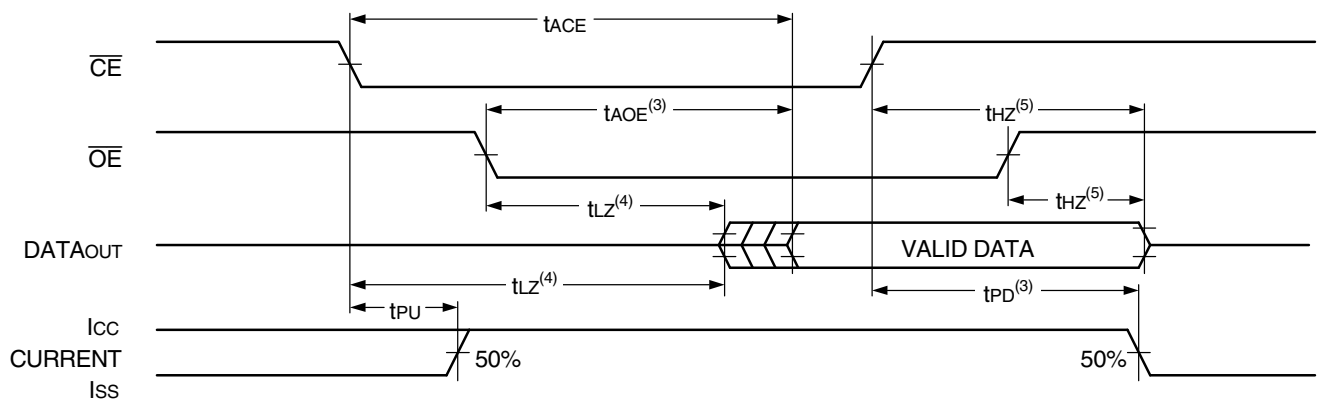

NOTES:

1. $\overline{R/\overline{W}} = V_{IH}$, $\overline{CE} = V_{IL}$, and is $\overline{OE} = V_{IL}$. Address is valid prior to the coincidental with \overline{CE} transition LOW.
2. t_{BDH} delay is required only in the case where the opposite port is completing a write operation to the same address location. For simultaneous read operations, \overline{BUSY} has no relationship to valid output data.
3. Start of valid data depends on which timing becomes effective last t_{AOE} , t_{ACE} , t_{AA} , and t_{BDH} .
4. Timing depends on which signal is asserted last, \overline{OE} or \overline{CE} .
5. Timing depends on which signal is de-asserted first, \overline{OE} or \overline{CE} .

AC Electrical Characteristics Over the Operating Temperature Supply Voltage Range^(5,6)

Symbol	Parameter	7132X20 ⁽²⁾ 7142X20 ⁽²⁾ Com'l Only		7132X25 ⁽²⁾ 7142X25 ⁽²⁾ Com'l, Ind & Military		7132X35 7142X35 Com'l & Military		Unit
		Min.	Max.	Min.	Max.	Min.	Max.	
WRITE CYCLE								
t _{wc}	Write Cycle Time ⁽³⁾	20	—	25	—	35	—	ns
t _{EW}	Chip Enable to End-of-Write	15	—	20	—	30	—	ns
t _{AW}	Address Valid to End-of-Write	15	—	20	—	30	—	ns
t _{AS}	Address Set-up Time	0	—	0	—	0	—	ns
t _{WP}	Write Pulse Width ⁽⁴⁾	15	—	15	—	25	—	ns
t _{WR}	Write Recovery Time	0	—	0	—	0	—	ns
t _{DW}	Data Valid to End-of-Write	10	—	12	—	15	—	ns
t _{HZ}	Output High-Z Time ⁽¹⁾	—	10	—	10	—	15	ns
t _{DH}	Data Hold Time	0	—	0	—	0	—	ns
t _{WZ}	Write Enable to Output in High-Z ⁽¹⁾	—	10	—	10	—	15	ns
t _{OW}	Output Active from End-of-Write ⁽¹⁾	0	—	0	—	0	—	ns

2692 tbl 09

Symbol	Parameter	7132X55 7142X55 Com'l & Military		7132X100 7142X100 Com'l & Military		Unit
		Min.	Max.	Min.	Max.	
WRITE CYCLE						
t _{wc}	Write Cycle Time ⁽³⁾	55	—	100	—	ns
t _{EW}	Chip Enable to End-of-Write	40	—	90	—	ns
t _{AW}	Address Valid to End-of-Write	40	—	90	—	ns
t _{AS}	Address Set-up Time	0	—	0	—	ns
t _{WP}	Write Pulse Width ⁽⁴⁾	30	—	55	—	ns
t _{WR}	Write Recovery Time	0	—	0	—	ns
t _{DW}	Data Valid to End-of-Write	20	—	40	—	ns
t _{HZ}	Output High-Z Time ⁽¹⁾	—	25	—	40	ns
t _{DH}	Data Hold Time	0	—	0	—	ns
t _{WZ}	Write Enable to Output in High-Z ⁽¹⁾	—	30	—	40	ns
t _{OW}	Output Active from End-of-Write ⁽¹⁾	0	—	0	—	ns

2692 tbl 10

NOTES:

1. Transition is measured 0mV from Low or High-impedance voltage with Output Test Load (Figure 2). This parameter is guaranteed by device characterization but is not production tested.
2. PLCC package only.
3. For Master/Slave combination, t_{wc} = t_{BAA} + t_{WP}, since R/W = V_{IL} must occur after t_{BAA}.
4. If \overline{OE} is LOW during a R/W controlled write cycle, the write pulse width must be the larger of t_{WP} or (t_{WZ} + t_{DW}) to allow the I/O drivers to turn off data to be placed on the bus for the required t_{DW}. If \overline{OE} is High during a R/W controlled write cycle, this requirement does not apply and the write pulse can be as short as the specified t_{WP}.
5. 'X' in part numbers indicates power rating (SA or LA).
6. Industrial temperature: for specific speeds, packages and powers contact your sales office.

Timing Waveform of Write Cycle No. 1, (R/\overline{W} Controlled Timing)^(1,5,8)

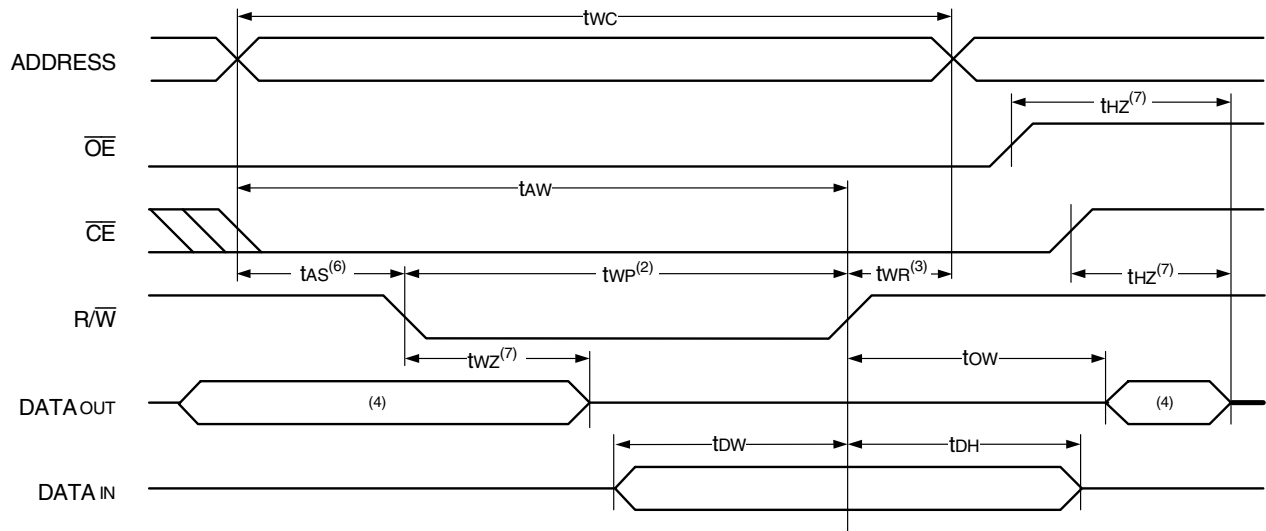

2692 drw 09

Timing Waveform of Write Cycle No. 2, (\overline{CE} Controlled Timing)^(1,5)

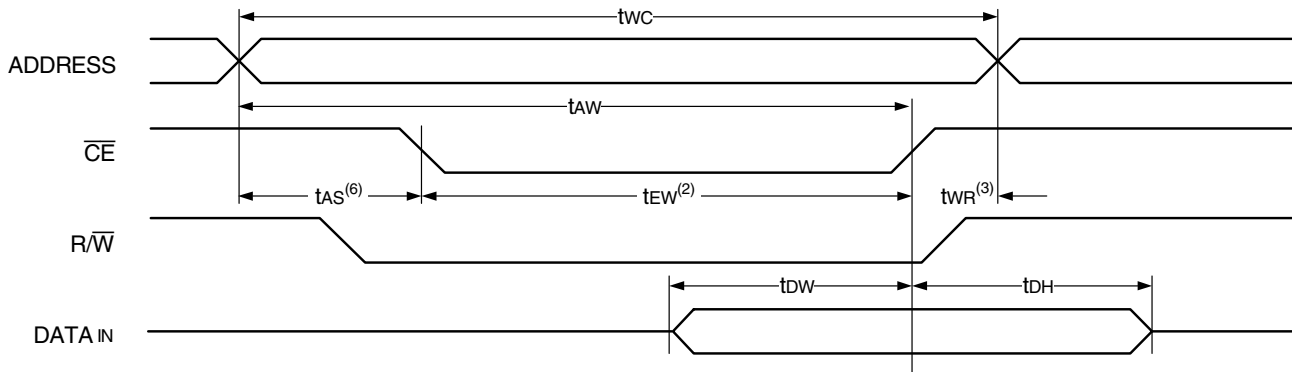

NOTES:

2692 drw 10

1. R/\overline{W} or \overline{CE} must be HIGH during all address transitions.
2. A write occurs during the overlap (t_{EW} or t_{WP}) of $\overline{CE} = V_{IL}$ and $R/\overline{W} = V_{IL}$.
3. t_{WR} is measured from the earlier of \overline{CE} or R/\overline{W} going HIGH to the end of the write cycle.
4. During this period, the I/O pins are in the output state and input signals must not be applied.
5. If the \overline{CE} LOW transition occurs simultaneously with or after the R/\overline{W} LOW transition, the outputs remain in the High-impedance state.
6. Timing depends on which enable signal (CE or R/\overline{W}) is asserted last.
7. This parameter is determined by device characterization, but is not production tested. Transition is measured 0mV from steady state with the Output Test Load (Figure 2).
8. If \overline{OE} is LOW during a R/\overline{W} controlled write cycle, the write pulse width must be the larger of t_{WP} or ($t_{WZ} + t_{OW}$) to allow the I/O drivers to turn off data to be placed on the bus for the required t_{OW} . If \overline{OE} is HIGH during a R/\overline{W} controlled write cycle, this requirement does not apply and the write pulse can be as short as the specified t_{WP} .

AC Electrical Characteristics Over the Operating Temperature and Supply Voltage Range^(7,8)

Symbol	Parameter	7132X20 ⁽¹⁾ 7142X20 ⁽¹⁾ Com'l Only		7132X25 ⁽²⁾ 7142X25 ⁽²⁾ Com'l, Ind & Military		7132X35 7142X35 Com'l & Military		Unit
		Min.	Max.	Min.	Max.	Min.	Max.	
BUSY Timing (For Master IDT7132 Only)								
t _{BAA}	$\overline{\text{BUSY}}$ Access Time from Address	—	20	—	20	—	20	ns
t _{BDA}	$\overline{\text{BUSY}}$ Disable Time from Address	—	20	—	20	—	20	ns
t _{BAC}	$\overline{\text{BUSY}}$ Access Time from Chip Enable	—	20	—	20	—	20	ns
t _{BDC}	$\overline{\text{BUSY}}$ Disable Time from Chip Enable	—	20	—	20	—	20	ns
t _{WDD}	Write Pulse to Data Delay ⁽²⁾	—	50	—	50	—	60	ns
t _{WH}	Write Hold After $\overline{\text{BUSY}}$ ⁽⁶⁾	12	—	15	—	20	—	ns
t _{DDD}	Write Data Valid to Read Data Delay ⁽²⁾	—	35	—	35	—	35	ns
t _{APS}	Arbitration Priority Set-up Time ⁽³⁾	5	—	5	—	5	—	ns
t _{BDD}	$\overline{\text{BUSY}}$ Disable to Valid Data ⁽⁴⁾	—	25	—	35	—	35	ns
BUSY Timing (For Slave IDT7142 Only)								
t _{WB}	Write to $\overline{\text{BUSY}}$ Input ⁽⁵⁾	0	—	0	—	0	—	ns
t _{WH}	Write Hold After $\overline{\text{BUSY}}$ ⁽⁶⁾	12	—	15	—	20	—	ns
t _{WDD}	Write Pulse to Data Delay ⁽²⁾	—	40	—	50	—	60	ns
t _{DDD}	Write Data Valid to Read Data Delay ⁽²⁾	—	30	—	35	—	35	ns

2692 tbl 11a

Symbol	Parameter	7132X55 7142X55 Com'l & Military		7132X100 7142X100 Com'l & Military		Unit
		Min.	Max.	Min.	Max.	
BUSY Timing (For Master IDT7132 Only)						
t _{BAA}	$\overline{\text{BUSY}}$ Access Time from Address	—	30	—	50	ns
t _{BDA}	$\overline{\text{BUSY}}$ Disable Time from Address	—	30	—	50	ns
t _{BAC}	$\overline{\text{BUSY}}$ Access Time from Chip Enable	—	30	—	50	ns
t _{BDC}	$\overline{\text{BUSY}}$ Disable Time from Chip Enable	—	30	—	50	ns
t _{WDD}	Write Pulse to Data Delay ⁽²⁾	—	80	—	120	ns
t _{WH}	Write Hold After $\overline{\text{BUSY}}$ ⁽⁶⁾	20	—	20	—	ns
t _{DDD}	Write Data Valid to Read Data Delay ⁽²⁾	—	55	—	100	ns
t _{APS}	Arbitration Priority Set-up Time ⁽³⁾	5	—	5	—	ns
t _{BDD}	$\overline{\text{BUSY}}$ Disable to Valid Data ⁽⁴⁾	—	50	—	65	ns
BUSY Timing (For Slave IDT7142 Only)						
t _{WB}	Write to $\overline{\text{BUSY}}$ Input ⁽⁵⁾	0	—	0	—	ns
t _{WH}	Write Hold After $\overline{\text{BUSY}}$ ⁽⁶⁾	20	—	20	—	ns
t _{WDD}	Write Pulse to Data Delay ⁽²⁾	—	80	—	120	ns
t _{DDD}	Write Data Valid to Read Data Delay ⁽²⁾	—	55	—	100	ns

NOTES:

2692 tbl 11b

1. PLCC package only.
2. Port-to-port delay through RAM cells from the writing port to the reading port, refer to "Timing Waveform of Write with Port -to-Port Read and BUSY."
3. To ensure that the earlier of the two ports wins.
4. t_{BDD} is a calculated parameter and is the greater of 0, t_{WDD} – t_{WP} (actual) or t_{DDD} – t_{WD} (actual).
5. To ensure that a write cycle is inhibited on port "B" during contention on port "A".
6. To ensure that a write cycle is completed on port "B" after contention on port "A".
7. 'X' in part numbers indicates power rating (SA or LA).
8. Industrial temperature: for specific speeds, packages and powers contact your sales office.

Timing Waveform of Write with Port-to-Port Read and **BUSY**^(2,3,4)

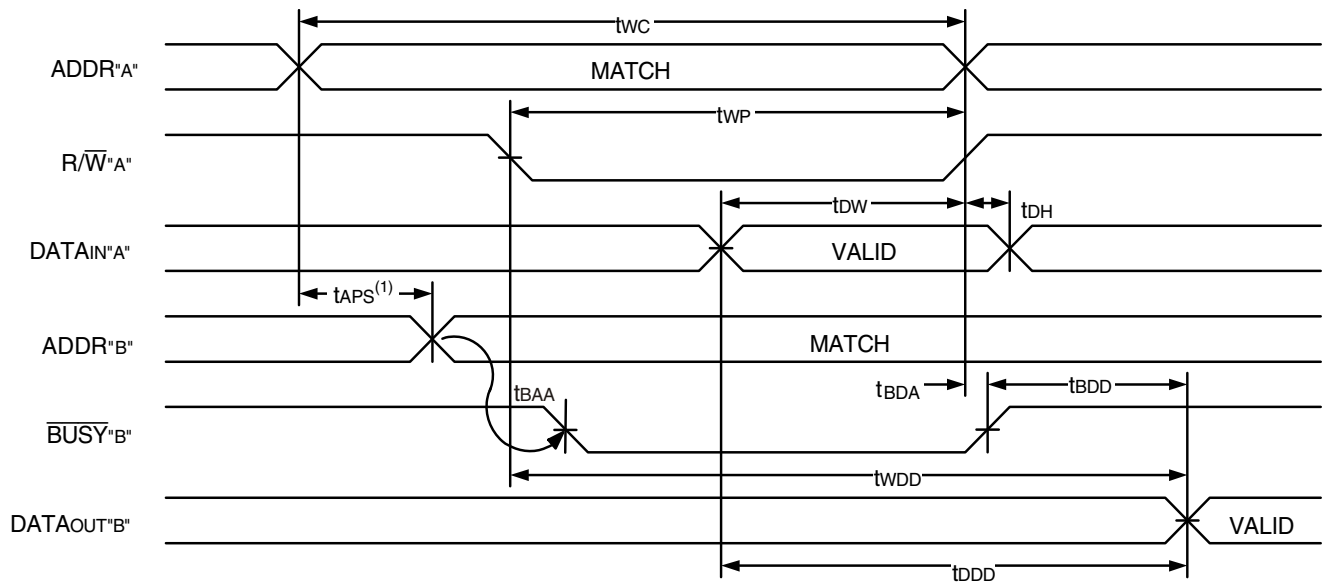

NOTES:

1. To ensure that the earlier of the two ports wins, tAPS is ignored for Slave (IDT7142).
2. $\overline{CE}_L = \overline{CE}_R = V_{IL}$
3. $\overline{OE} = V_{IL}$ for the reading port.
4. All timing is the same for the left and right ports. Port "A" may be either the left or right port. Port "B" is opposite from port "A".

2692 drw 11

Timing Waveform of Write with **BUSY**⁽⁴⁾

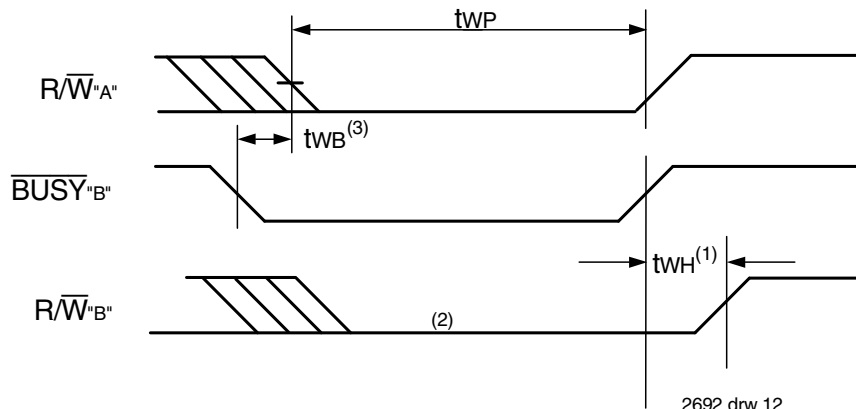

2692 drw 12

NOTES:

1. tWH must be met for both \overline{BUSY} Input (IDT7142, slave) or Output (IDT7132, master).
2. \overline{BUSY} is asserted on port "B" blocking R/W'B', until \overline{BUSY} goes HIGH.
3. tWB applies only to the slave version (IDT7142).
4. All timing is the same for the left and right ports. Port 'A' may be either the left or right port. Port "B" is opposite from port "A".

Timing Waveform of **BUSY** Arbitration Controlled by **CE** Timing⁽¹⁾

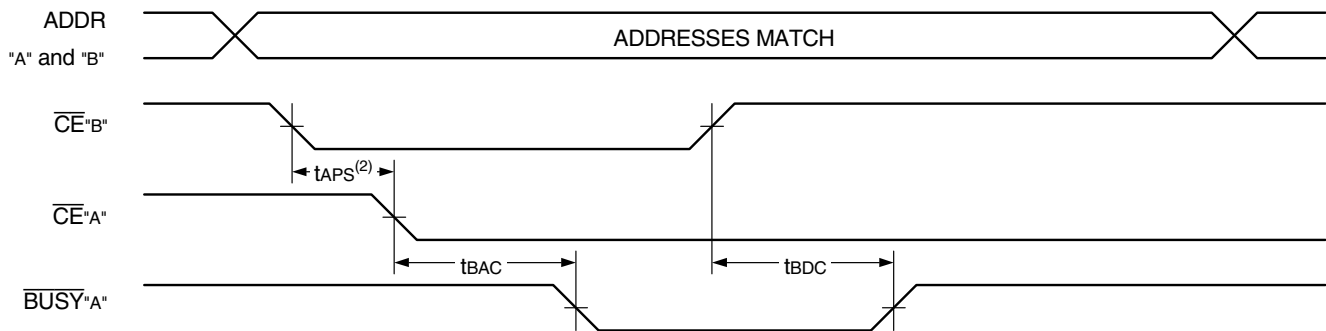

2692 drw 13

Timing Waveform of **BUSY** Arbitration Controlled by Address Match Timing⁽¹⁾

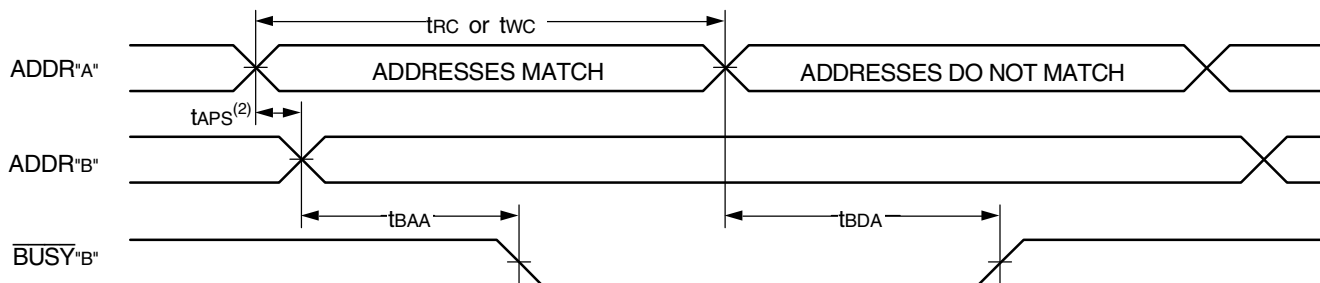

2692 drw 14

NOTES:

1. All timing is the same for left and right ports. Port "A" may be either left or right port. Port "B" is the opposite from port "A".
2. If tAPS is not satisfied, the **BUSY** will be asserted on one side or the other, but there is no guarantee on which side **BUSY** will be asserted (7132 only).

Truth Tables

Table I. Non-Contention Read/Write Control⁽⁴⁾

Left or Right Port ⁽¹⁾				Function
R/W	CE	OE	D0-7	
X	H	X	Z	Port Disabled and in Power-Down Mode, ISB2 or ISB4
X	H	X	Z	$\overline{CE}_R = \overline{CE}_L = V_{IH}$, Power-Down Mode, ISB1 or ISB3
L	L	X	DATAIN	Data on Port Written into Memory ⁽²⁾
H	L	L	DATAOUT	Data in Memory Output on Port ⁽³⁾
X	L	H	Z	High Impedance Outputs

2692 tbl 12

NOTES:

1. A_{0L} - A_{10L} ≠ A_{0R} - A_{10R}
2. If **BUSY** = L, data is not written.
3. If **BUSY** = L, data may not be valid, see twDD and tDD timing.
4. 'H' = V_{IH}, 'L' = V_{IL}, 'X' = DON'T CARE, 'Z' = HIGH IMPEDANCE

Table II — Address **BUSY** Arbitration

Inputs			Outputs		Function
\overline{CE}_L	\overline{CE}_R	AOL-A10L AOR-A10R	$\overline{BUSY}_L^{(1)}$	$\overline{BUSY}_R^{(1)}$	
X	X	NO MATCH	H	H	Normal
H	X	MATCH	H	H	Normal
X	H	MATCH	H	H	Normal
L	L	MATCH	(2)	(2)	Write Inhibit ⁽³⁾

2692 tbl 13

NOTES:

1. Pins \overline{BUSY}_L and \overline{BUSY}_R are both outputs for IDT7132 (master). Both are inputs for IDT7142 (slave). \overline{BUSY}_x outputs on the IDT7132 are open drain, not push-pull outputs. On slaves the \overline{BUSY}_x input internally inhibits writes.
2. 'L' if the inputs to the opposite port were stable prior to the address and enable inputs of this port. 'H' if the inputs to the opposite port became stable after the address and enable inputs of this port. If t_{APS} is not met, either \overline{BUSY}_L or \overline{BUSY}_R = LOW will result. \overline{BUSY}_L and \overline{BUSY}_R outputs can not be LOW simultaneously.
3. Writes to the left port are internally ignored when \overline{BUSY}_L outputs are driving LOW regardless of actual logic level on the pin. Writes to the right port are internally ignored when \overline{BUSY}_R outputs are driving LOW regardless of actual logic level on the pin.

Functional Description

The IDT7132/IDT7142 provides two ports with separate control, address and I/O pins that permit independent access for reads or writes to any location in memory. The IDT7132/IDT7142 has an automatic power down feature controlled by \overline{CE} . The \overline{CE} controls on-chip power down circuitry that permits the respective port to go into a standby mode when not selected ($\overline{CE} = V_{IH}$). When a port is enabled, access to the entire memory array is permitted.

Busy Logic

Busy Logic provides a hardware indication that both ports of the RAM have accessed the same location at the same time. It also allows one of the two accesses to proceed and signals the other side that the RAM is "Busy". The \overline{BUSY} pin can then be used to stall the access until the operation on the other side is completed. If a write operation has been attempted from the side that receives a busy indication, the write signal is gated internally to prevent the write from proceeding.

The use of \overline{BUSY} Logic is not required or desirable for all applications. In some cases it may be useful to logically OR the \overline{BUSY} outputs together and use any \overline{BUSY} indication as an interrupt source to flag the event of an illegal or illogical operation.

The \overline{BUSY} outputs on the IDT7132 RAM master are open drain type outputs and require open drain resistors to operate. If these RAMs are being expanded in depth, then the \overline{BUSY} indication for the resulting array does not require the use of an external AND gate.

Width Expansion with Busy Logic Master/Slave Arrays

When expanding an SRAM array in width while using \overline{BUSY} logic, one master part is used to decide which side of the SRAM array will receive a \overline{BUSY} indication, and to output that indication. Any number of slaves to be addressed in the same address range as the master, use the \overline{BUSY} signal as a write inhibit signal. Thus on the IDT7132/IDT7142 SRAMs the \overline{BUSY} pin is an output if the part is Master (IDT7132), and the \overline{BUSY} pin is an input if the part is a Slave (IDT7142) as shown in Figure 3.

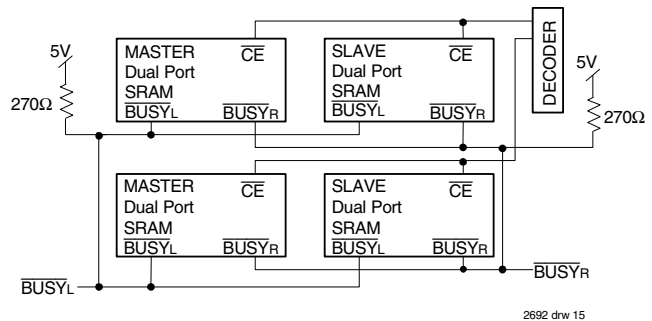

Figure 4. Busy and chip enable routing for both width and depth expansion with IDT7132 (Master) and (Slave) IDT7142 SRAMs.

If two or more master parts were used when expanding in width, a split decision could result with one master indicating \overline{BUSY} on one side of the array and another master indicating \overline{BUSY} on one other side of the array. This would inhibit the write operations from one port for part of a word and inhibit the write operations from the other port for the other part of the word.

The \overline{BUSY} arbitration, on a Master, is based on the chip enable and address signals only. It ignores whether an access is a read or write. In a master/slave array, both address and chip enable must be valid long enough for a \overline{BUSY} flag to be output from the master before the actual write pulse can be initiated with either the R/\overline{W} signal or the byte enables. Failure to observe this timing can result in a glitched internal write inhibit signal and corrupted data in the slave.

Ordering Information

XXXX	A	999	A	A	A	A	
Device Type	Power	Speed	Package		Process/ Temperature Range		
							Blank 8 Tube Tape and Reel
							Blank (1) B Commercial (0°C to +70°C) Industrial (-40°C to +85°C) Military (-55°C to +125°C) Compliant to MIL-PRF-38535 QML
							G(2) Green
							P C J L F 48-pin Plastic DIP (PDG48) 48-pin Sidebrazed DIP (SB48) 52-pin PLCC (PLG52) 48-pin LCC (LC48) 48-pin Ceramic Flatpack (FP48)
							20 25 35 55 100 Commercial Only Industrial & Military Commercial & Military Commercial, Industrial & Military Commercial & Military
							LA SA Low Power Standard Power
							7132 7142 16K (2K x 8-Bit) MASTER Dual-Port RAM 16K (2K x 8-Bit) SLAVE Dual-Port RAM

} Speed in nanoseconds

2692 drw 16

NOTES:

- Industrial temperature range is available. For specific speeds, packages and powers contact your sales office.
- Green parts available. For specific speeds, packages and powers contact your local sales office.
LEAD FINISH (SnPb) parts are Obsolete excluding FP48, LC48 & SB48. Product Discontinuation Notice - PDN# SP-17-02
Note that information regarding recently obsoleted parts are included in this datasheet for customer convenience.

Orderable Part Information

Speed (ns)	Orderable Part ID	Pkg. Code	Pkg. Type	Temp. Grade
20	7132LA20JG	PLG52	PLCC	C
	7132LA20JG8	PLG52	PLCC	C
25	7132LA25JGI	PLG52	PLCC	I
	7132LA25JGI8	PLG52	PLCC	I
	7132LA25L48B	LC48	LCC	M
35	7132LA35C	SB48	SB	C
	7132LA35CB	SB48	SB	M
	7132LA35FB	FP48	FPAK	M
	7132LA35L48B	LC48	LCC	M
	7132LA35PDG	PDG48	PDIP	C
55	7132LA55C	SB48	SB	C
	7132LA55CB	SB48	SB	M
	7132LA55FB	FP48	FPAK	M
	7132LA55L48B	LC48	LCC	M
	7132LA55PDGI	PDG48	PDIP	I
100	7132LA100C	SB48	SB	C
	7132LA100CB	SB48	SB	M
	7132LA100L48B	LC48	LCC	M
	7132LA100PDG	PDG48	PDIP	C

Speed (ns)	Orderable Part ID	Pkg. Code	Pkg. Type	Temp. Grade
25	7132SA25L48B	LC48	LCC	M
35	7132SA35C	SB48	SB	C
	7132SA35CB	SB48	SB	M
	7132SA35JG	PLG52	PLCC	C
	7132SA35JG8	PLG52	PLCC	C
	7132SA35L48B	LC48	LCC	M
55	7132SA55C	SB48	SB	C
	7132SA55CB	SB48	SB	M
	7132SA55JG	PLG52	PLCC	C
	7132SA55L48B	LC48	LCC	M
100	7132SA100C	SB48	SB	C
	7132SA100CB	SB48	SB	M
	7132SA100L48B	LC48	LCC	M

Orderable Part Information (con't)

Speed (ns)	Orderable Part ID	Pkg. Code	Pkg. Type	Temp. Grade
20	7142LA20JG	PLG52	PLCC	C
	7142LA20JG8	PLG52	PLCC	C
25	7142LA25JGI	PLG52	PLCC	I
	7142LA25JGI8	PLG52	PLCC	I
35	7142LA35C	SB48	SB	C
	7142LA35CB	SB48	SB	M
	7142LA35L48B	LC48	LCC	M
	7142LA35PDG	PDG48	PDIP	C
55	7142LA55C	SB48	SB	C
	7142LA55CB	SB48	SB	M
	7142LA55L48B	LC48	LCC	M
100	7142LA100C	SB48	SB	C
	7142LA100CB	SB48	SB	M
	7142LA100L48B	LC48	LCC	M
	7142LA100PDG	PDG48	PDIP	C

Speed (ns)	Orderable Part ID	Pkg. Code	Pkg. Type	Temp. Grade
35	7142SA35C	SB48	SB	C
	7142SA35CB	SB48	SB	M
	7142SA35L48B	LC48	LCC	M
55	7142SA55C	SB48	SB	C
	7142SA55CB	SB48	SB	M
	7142SA55L48B	LC48	LCC	M
100	7142SA100C	SB48	SB	C
	7142SA100CB	SB48	SB	M
	7142SA100L48B	LC48	LCC	M

Datasheet Document History

03/24/99:		Initiated datasheet document history
		Converted to new format
		Cosmetic and typographical corrections
	Pages 2 and 3	Added additional notes to pin configurations
06/08/99:		Changed drawing format
08/26/99:	Page 14	Changed Busy Logic and Width Expansion copy
11/10/99:		Replaced IDT logo
01/12/00:	Pages 1 and 2	Moved full "Description" to page 2 and adjusted page layouts
	Page 1	Added "(LAonly)" to paragraph
	Page 2	Fixed P48-1 body package description
	Page 3	Increased storage temperature parameters
		Clarified TA parameter
	Page 4	DC Electrical parameters—changed wording from "open" to "disabled"
	Page 6	Added asteriks to Figures 1 and 3 in drw 06
	Page 14	Corrected part numbers
		Changed $\pm 500\text{mV}$ to 0mV in notes

Datasheet Document History (con't)

06/11/04:	Page 6 Page 4, 7, 9, 11 & 15 Page 5 Page 6	Corrected errors in Figure 3 by changing 1250Ω to 270Ω and removing "or Int" and Int Clarified Industrial temp offering for 25ns Removed $\overline{\text{INT}}$ from V_{OL} parameter in DC Electrical Characteristics table Updated AC Test Conditions Input Rise/Fall Times from 5ns to 3ns
01/17/06:	Page 1 Page 15 Page 16	Added green availability to features Added green indicator to ordering information Replaced IDT address with new
10/21/08:	Page 15	Removed "IDT" from orderable part number
09/20/10:	Page 14	Corrected $\overline{\text{BUSY}}$ description to indicate open drain outputs
10/03/14:	Page 2 Page 15 Page 2, 3 & 15 Page 15	Removed IDT in reference to fabrication Added Tape and Reel to Ordering Information The package codes P48-1, C48-2, J52-1, L48-1 & F48-1 changed to P48, C48, J52, L48 & F48 respectively to match standard package codes Add annotation ⁽³⁾ to 25ns speed grade to indicate that 25ns is not available in DIP packages
10/08/14:	Page 15	Corrected a typo
11/20/15:	Page 15	Added ⁽⁴⁾ footnote annotation to the "P" package in the Ordering Information. Added footnote 4, For "P", Plastic DIP, when ordering green package, the suffix is "PDG".
07/03/18:		Updated L package in the Ordering Information to L48 Product Discontinuation Notice - PDN# SP-17-02 Last time buy expires June 15, 2018
05/27/21:	Pages 1 - 20 Page 2, 3 & 16 Pages 17 & 18	Rebranded as Renesas datasheet Rotated LC48 LCC, FP48 Flatpack & PLG52 PLCC pin configurations to accurately reflect pin 1 orientation and updated package codes Added Orderable Part Information tables

IMPORTANT NOTICE AND DISCLAIMER

RENESAS ELECTRONICS CORPORATION AND ITS SUBSIDIARIES (“RENESAS”) PROVIDES TECHNICAL SPECIFICATIONS AND RELIABILITY DATA (INCLUDING DATASHEETS), DESIGN RESOURCES (INCLUDING REFERENCE DESIGNS), APPLICATION OR OTHER DESIGN ADVICE, WEB TOOLS, SAFETY INFORMATION, AND OTHER RESOURCES “AS IS” AND WITH ALL FAULTS, AND DISCLAIMS ALL WARRANTIES, EXPRESS OR IMPLIED, INCLUDING, WITHOUT LIMITATION, ANY IMPLIED WARRANTIES OF MERCHANTABILITY, FITNESS FOR A PARTICULAR PURPOSE, OR NON-INFRINGEMENT OF THIRD PARTY INTELLECTUAL PROPERTY RIGHTS.

These resources are intended for developers skilled in the art designing with Renesas products. You are solely responsible for (1) selecting the appropriate products for your application, (2) designing, validating, and testing your application, and (3) ensuring your application meets applicable standards, and any other safety, security, or other requirements. These resources are subject to change without notice. Renesas grants you permission to use these resources only for development of an application that uses Renesas products. Other reproduction or use of these resources is strictly prohibited. No license is granted to any other Renesas intellectual property or to any third party intellectual property. Renesas disclaims responsibility for, and you will fully indemnify Renesas and its representatives against, any claims, damages, costs, losses, or liabilities arising out of your use of these resources. Renesas' products are provided only subject to Renesas' Terms and Conditions of Sale or other applicable terms agreed to in writing. No use of any Renesas resources expands or otherwise alters any applicable warranties or warranty disclaimers for these products.

(Disclaimer Rev.1.0 Mar 2020)

Corporate Headquarters

TOYOSU FORESIA, 3-2-24 Toyosu,
Koto-ku, Tokyo 135-0061, Japan
www.renesas.com

Contact Information

For further information on a product, technology, the most up-to-date version of a document, or your nearest sales office, please visit:
www.renesas.com/contact/

Trademarks

Renesas and the Renesas logo are trademarks of Renesas Electronics Corporation. All trademarks and registered trademarks are the property of their respective owners.