



Optical Sensor Product Data Sheet LTR-91400

Spec No.: DS86-2016-0050

Effective Date: 09/14/2016

Revision: -

LITE-ON DCC

RELEASE

BNS-OD-FC001/A4

OPTICAL SENSOR LTR-91400

Description

LTR-91400 is an integrated low voltage I²C ambient light sensor [ALS], gesture sensor [GS] and proximity sensor [PS], with built-in emitter in a single miniature chipLED lead-free surface mount package.

This sensor converts light intensity to a digital output signal capable of direct I2C interface. The gesture sensor provides object motion direction information based on the reflected IR light detected by the 4 photodiodes for East, West, North and South direction. Besides, ambient light sensor provides a linear response over a wide dynamic range and is well suited to applications under high ambient brightness. With built-in proximity sensor (emitter and detector), it offers the feature to detect object at a user configurable distance.

The sensor supports an interrupt feature that removes the need to poll the sensor for a reading which improves system efficiency. The sensor also supports several features that help to minimize the occurrence of false triggering. This CMOS design and factory-set one time trimming capability ensure minimal sensor-to-sensor variations for ease of manufacturability to the end customers.

Application

To control brightness of the display panel, and/or detection of object or motion in mobile, computing, and consumer devices.

Features

- I²C interface (Standard mode @100kHz or Fast mode

@400kHz)

- Gesture, Ambient Light, and Proximity Sensing in one ultra-small ChipLED package
- Very low power consumption with sleep mode capability
- Operating voltage ranges: 2.4V to 3.6V
- Operating temperature ranges: -30 to +70 °C
- Programmable interrupt function for ALS, PS, and GS.
- Built-in temperature compensation circuit
- RoHS and Halogen free compliant
- **GS Features**
 - 4 photodiodes for East, West, North and South direction
 - 32 dataset storage FIFO
 - 8-bit effective resolution
 - Programmable LED drive settings
 - Programmable crosstalk correction
- **ALS Features**
 - 16-bits effective resolution
 - Wide dynamic range of 1:15,000,000 with linear response
 - Close to human eye spectral response
 - Automatic rejection for 50Hz/60Hz lighting flicker
- **PS Features**
 - Built-in LED driver and detector
 - 11-bit effective resolution
 - Programmable LED drive settings
 - Programmable crosstalk correction
 - High Ambient Light Suppression

**OPTICAL SENSOR
LTR-91400**

Ordering Information

Part Number	Packaging Type	Package	Quantity
LTR-91400	Tape and Reel	8-pins Chip-led package	8000

**OPTICAL SENSOR
LTR-91400**

1. Outline Dimensions

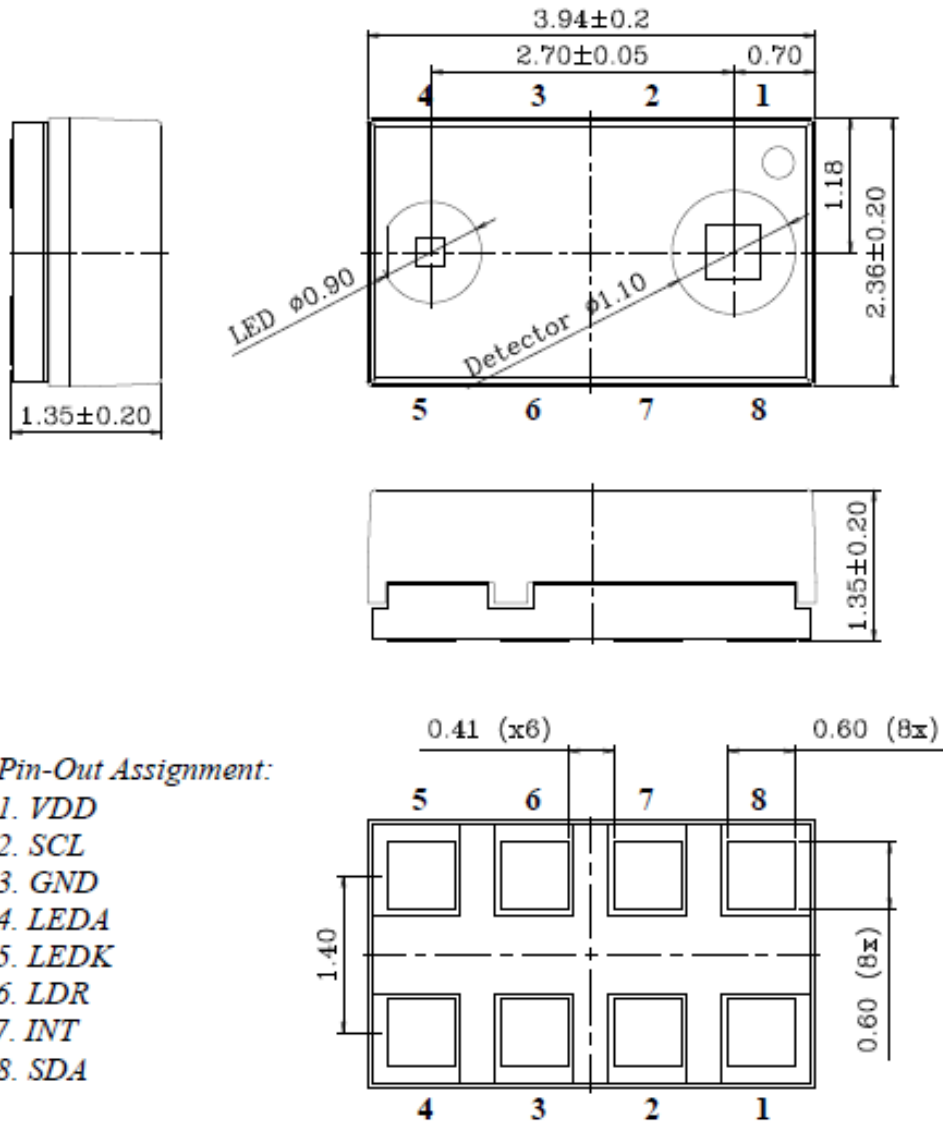

Pin-Out Assignment:

- 1. VDD
- 2. SCL
- 3. GND
- 4. LEDA
- 5. LEDK
- 6. LDR
- 7. INT
- 8. SDA

Note:

- 1. All dimensions are in millimeters

2. Functional Block Diagram

LTR-91400 contains 5 integrated photodiodes (1 for ambient light and 4 photodiodes for East, West, North, and South direction) for respective photocurrent measurement. The photodiode currents are converted to digital values by ADCs. The sensor also included a driver circuit for an external IRLED, as well as some peripheral circuits such as an internal oscillator, a current source, voltage reference, and internal fuses to store trimming information.

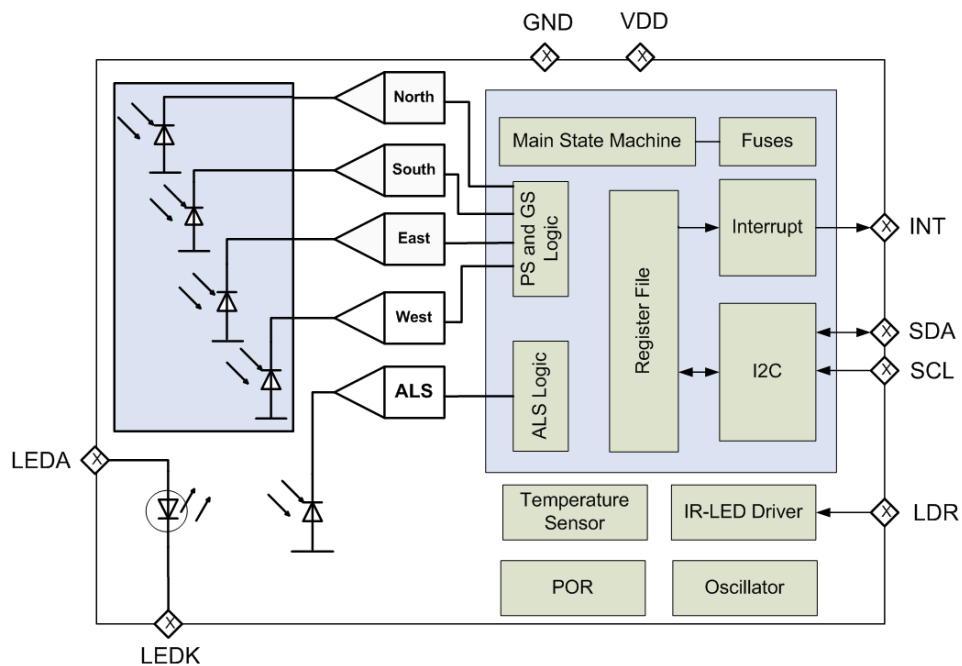

3. Application Circuit

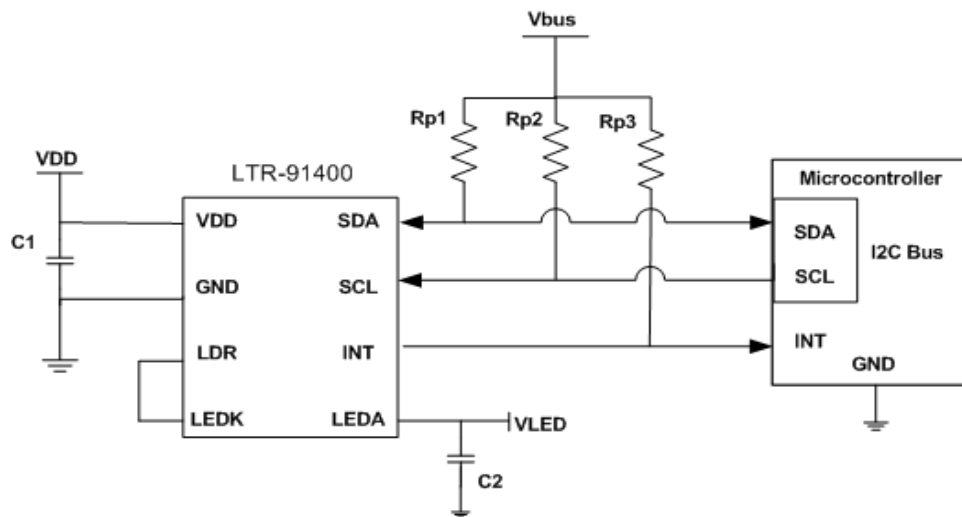

Note: It is a must that VDD and VLED to be separated.

I/O Pins Configuration Table

Pin	I/O Type	Symbol	Description
1	Supply	VDD	Power Supply Voltage
2	IN	SCL	I ² C serial data
3	Ground	GND	Power Supply Ground. All voltages are referenced to GND
4	IN	LEDA	LED Anode. Connect to VLEDA on PCB
5	NC	LEDK	LED Cathode. Connect to LDR pin when using internal LED driver circuit
6	OUT	LDR	Proximity IR LED driver
7	OUT	INT	Interrupt
8	IN/OUT	SDA	I ² C serial clock

Recommended Application Circuit Components

Component	Recommended Value
Rp1, Rp2, Rp3 [1]	1 k Ω to 10 k Ω
C1, C2	1 μ F \pm 20%, X7R Ceramic

Notes:

[1] Selection of pull-up resistors value is dependent on bus capacitance values. For more details, please refer to I2C Specifications: http://www.nxp.com/documents/user_manual/UM10204.pdf

4. Rating and Specification

4.1. Absolute Maximum Rating at Ta=25°C

Parameter	Symbol	Rating	Unit
Supply Voltage	VDD	3.8	V
Digital Voltage Range	SCL, SDA, INT	-0.5 to 3.8	V
Digital Output Current	SCL, SDA, INT	-1 to 20	mA
Storage Temperature	T _{stg}	-40 to 85	°C

Note: Exceeding these ratings could cause damage to the sensor. All voltages are with respect to ground. Currents are positive into, negative out of the specified terminal.

4.2. Recommended Operating Conditions

Parameter	Symbol	Min.	Typ.	Max.	Unit
Supply Voltage	VDD	2.4		3.6	V
LED Supply Voltage	VLED	2.5		4.35	V
Interface Bus Power Supply Voltage	VIO	1.7		3.6	V
I2C Bus Input Pin High Voltage	VIH_SCL, VIH_SDA	1.2			V
I2C Bus Input Pin Low Voltage	VIL_SCL, VIL_SDA			0.6	V
Operating Temperature	T _{ope}	-30		70	°C

4.3. Electrical Specifications (VDD = 3.0V, Ta=25°C, unless otherwise noted)

Parameter	Min.	Typ.	Max	Unit	Condition
Active Supply Current 1		210		µA	ALS in active mode ALS integration time = 100ms ALS measurement repeat rate = 400ms
Active Supply Current 2		100		µA	PS in active mode, 25% Duty Cycle, 8µs Pulse Width, 100mA, 8 Pulses PS measurement repeat rate = 100ms Not including VLED current
Active Supply Current 3		450		µA	GS+PS in active mode, 25% Duty Cycle, 8µs Pulse Width, 100mA, 8 Pulses PS measurement repeat rate = 100ms Full 32 dataset, GS wait time = 0ms
Standby Current			5	µA	Standby / Sleep Mode
Initial Startup Time			100	ms	Min wait time after power up (supply ramp-up to 2.4V) before sending I2C commands

OPTICAL SENSOR LTR-91400

Wakeup Time from Standby	10	ms	Max wait time after turning device from stand-by to active before measurements starts
Leakage Current	-5	5	uA SDA, SCL, INT pins

4.4. Characteristics ALS Ambient Light Sensor

Parameter	Min.	Typ.	Max.	Unit	Condition
Full ADC Resolution		16		bits	
Dark Count		0	10	count	Lux = 0, T _{ope} =25°C
ADC Ch0 Count Gain X128		34000		count	Lux=100, White LED, CCT~5K
ALS Lux Accuracy	-20		20	%	
50/60 Hz flicker noise error	-5		5	%	

4.5. Characteristics Proximity Sensor

Parameter	Min.	Typ.	Max.	Unit	Condition
Full ADC Resolution		11		bits	
LED peak wavelength		940		nm	
Detection Distance	50			mm	Under dark tinted window 25% Duty Cycle, 8us Pulse Width, 100mA, 2 Pulses, 18% Gray Card
LED Pulse Width		8		us	
LED Duty Cycle		25		%	
LED Peak Current	12.5		300	mA	Programmable LED current
Measurement repeat rate	6.125		800	msec	
Number of LED Pulses	1		15	Pulses	
Ambient Light Suppression			50K	lux	Direct Sunlight

4.6. Characteristics Gesture Sensor

Parameter	Min.	Typ.	Max.	Unit	Condition
Full ADC Resolution		8		bits	
LED peak wavelength		940		nm	
FIFO RAM		32		set	Sets of 4 bytes
Detection Distance		10		cm	With recommended optical design
LED Pulse Width		8		us	
LED Duty Cycle		25		%	
LED Peak Current	12.5		300	mA	

OPTICAL SENSOR LTR-91400

Measurement repeat rate	6.125	800	msec	Follow PS measurement repeat rate
Number of LED Pulses	1	15	Pulses	
Ambient Light Suppression		50K	lux	Direct Sunlight

4.7. Typical Device Parameter (VDD = 3.0V, Ta=25°C, default power-up settings, unless otherwise noted)

Power Spectral Responsivity of Detector

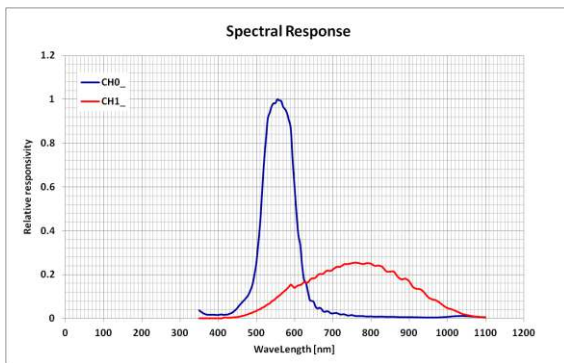

Figure 4.7.1: Spectral Response of ALS

Angular of Incidence

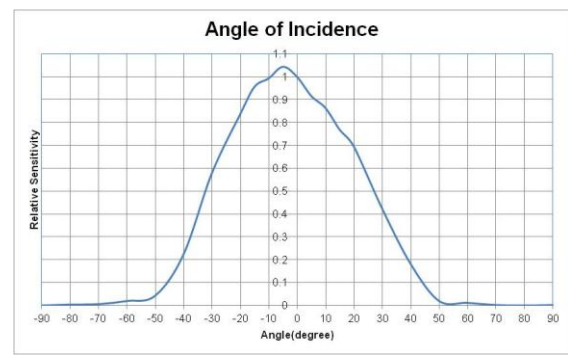

Figure 4.7.2: Angular of ALS

PS Response

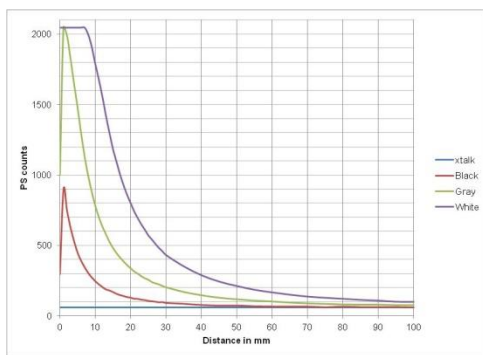

Figure 4.7.3: PS response

Angular of LED

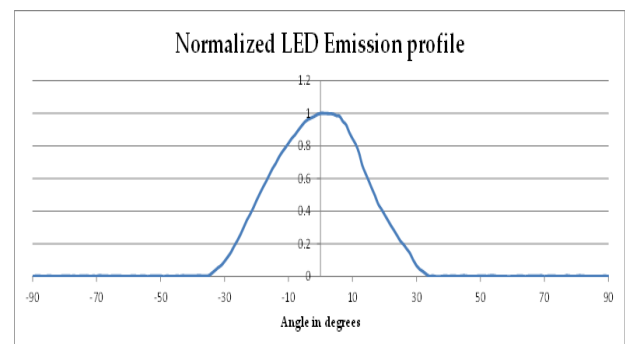
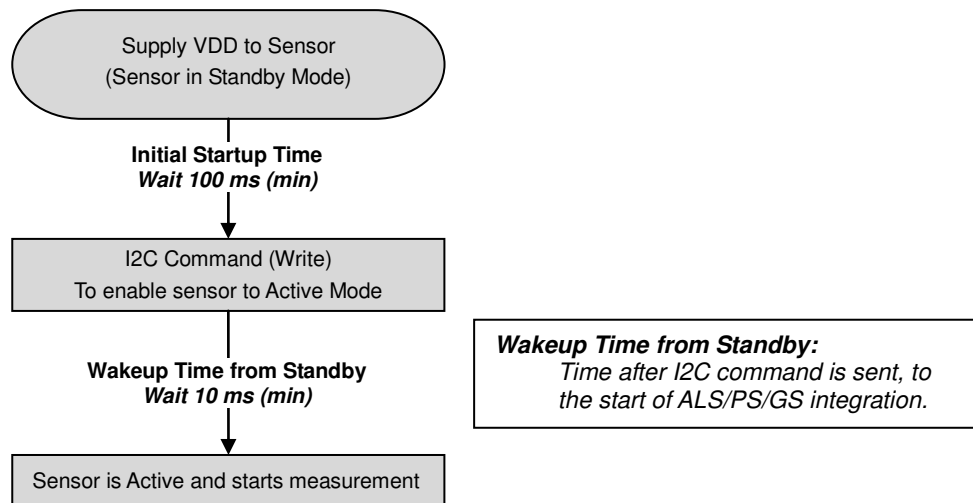

Figure 4.7.4: Angular of LED

4.8. Startup Sequence



AC Electrical Characteristics

All specifications are at VBus = 1.7V, T_{ope} = 25°C, unless otherwise noted.

Parameter	Symbol	Min.	Max.	Unit
SCL clock frequency	f_{SCL}	100	400	kHz
Bus free time between a STOP and START condition	t_{BUF}	1.3		us
Hold time (repeated) START condition. After this period, the first clock pulse is generated	$t_{HD;STA}$	0.6		us
LOW period of the SCL clock	t_{LOW}	1.3		us
HIGH period of the SCL clock	t_{HIGH}	0.6		us
Set-up time for a repeated START condition	$t_{SU;STA}$	0.6		us
Set-up time for STOP condition	$t_{SU;STO}$	0.6		us
Rise time of both SDA and SCL signals	t_r	30	300	ns
Fall time of both SDA and SCL signals	t_f	30	300	ns
Data hold time	$t_{HD;DAT}$	30		s
Data setup time	$t_{SU;DAT}$	100		ns
Pulse width of spikes which must be suppressed by the input filter	t_{SP}	0	50	ns

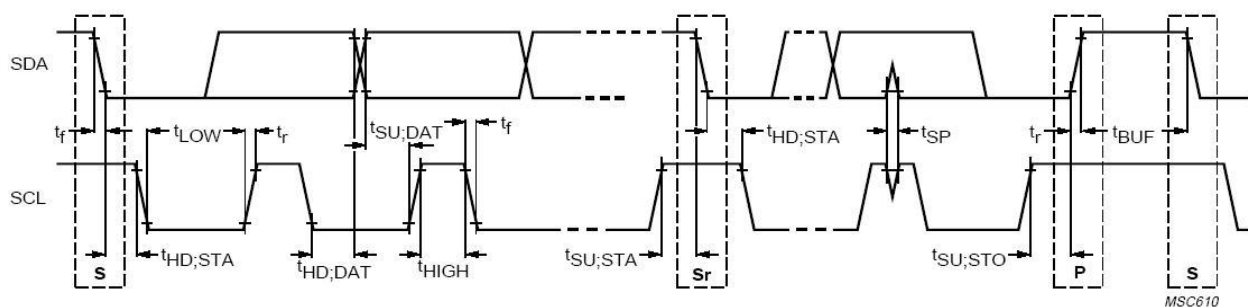

Definition of timing for I²C bus

5. Principle of Operation

5.1. I2C Protocol

5.1.1. I2C Write Protocol (type 1)

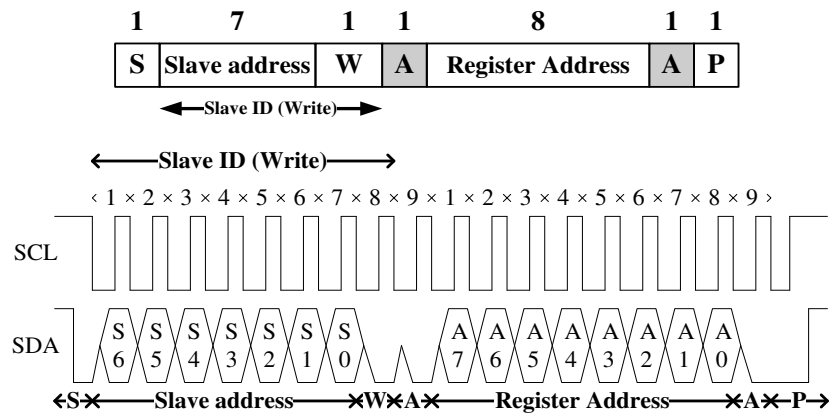

5.1.2. I2C Write Protocol (type 2)

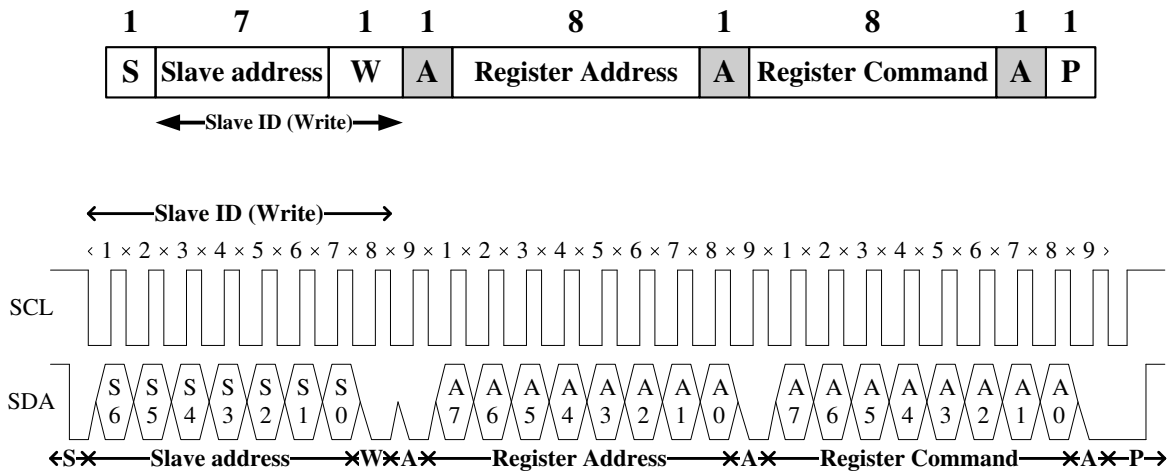

5.1.3. I2C Read Protocol

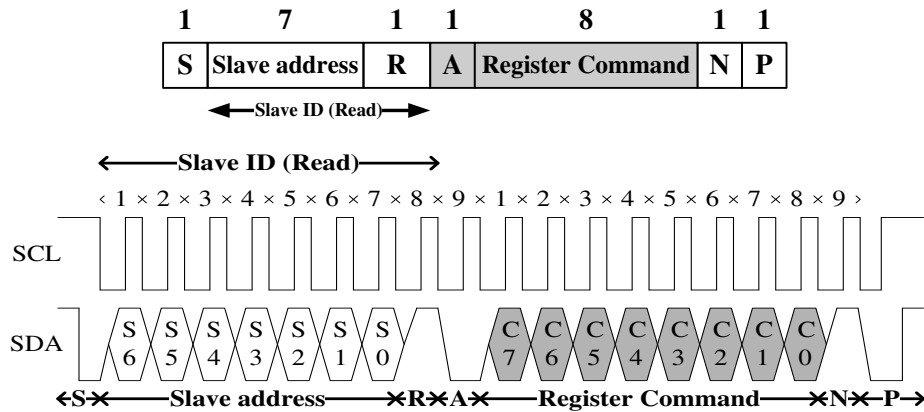

5.1.4. I2C Read (Combined format) Protocol

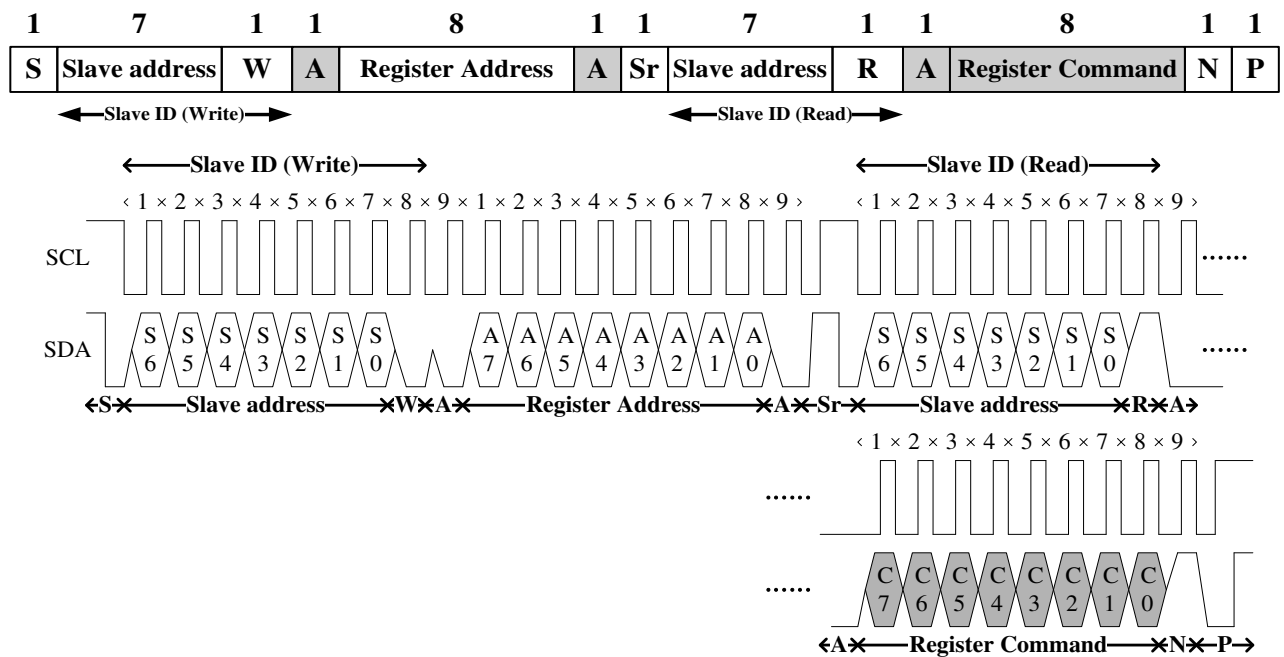

A Acknowledge (0 for an ACK)
S Start condition
P Stop condition
W Write (0 for writing)
 Slave-to-master

N Non-Acknowledge(1 for an NACK)
Sr Repeated Start condition
R Read (1 for read)
 Master-to-Slave

5.2. I2C Slave Address

The 7 bits slave address for this sensor is 0x23H. A read/write bit should be appended to the slave address by the master device to properly communicate with the sensor.

I ² C Slave Address									
Command Type	(0x23H)							(0x23H)	(0x23H)
	Bit7	Bit6	Bit5	Bit4	Bit3	Bit2	Bit1	Bit0	
Write	0	1	0	0	0	1	1	0	0x46H
Read	0	1	0	0	0	1	1	1	0x47H

6. Register Set

Address	R / W	Register Name	Description	Reset Value
0x80	RW	ALS_CTRL	ALS operation mode control, and SW reset	0x00
0x81	RW	PS_CTRL	PS operation mode control	0x40
0x82	RW	GS_CTRL	GS operation mode control	0x00
0x83	RW	ALS_MEAS_RATE	ALS measurement rate in active mode	0x0B
0x84	RW	ALS_THRES_UP_LSB	ALS interrupt upper threshold, LSB	0xFF
0x85	RW	ALS_THRES_UP_MSB	ALS interrupt upper threshold, MSB	0xFF
0x86	RW	ALS_THRES_LOW_LSB	ALS interrupt lower threshold, LSB	0x00
0x87	RW	ALS_THRES_LOW_MSB	ALS interrupt lower threshold, MSB	0x00
0x88	RW	PS_LED	PS LED settings	0x70
0x89	RW	PS_MEAS_RATE	PS measurement rate settings	0x40
0x8A	RW	RESERVED	RESERVED	0x00
0x8B	RW	PS_XTALK_NE_LSB	Crosstalk correction on PS North East detector, LSB	0x00
0xCB	RW	PS_XTALK_NE_MSB	Crosstalk correction on PS North East detector, MSB	0x00
0x8C	RW	PS_XTALK_SW_LSB	Crosstalk correction on PS South West detector, LSB	0x00
0xCC	RW	PS_XTALK_SW_MSB	Crosstalk correction on PS South West detector, MSB	0x00
0x8D	RW	PS_THRES_UP_LSB	PS interrupt upper threshold, LSB	0xFF
0xCD	RW	PS_THRES_UP_MSB	PS interrupt upper threshold, MSB	0x07
0x8E	RW	PS_THRES_LOW_LSB	PS interrupt lower threshold, LSB	0x00
0xCE	RW	PS_THRES_LOW_MSB	PS interrupt lower threshold, MSB	0x00
0x8F	RW	INTERTUPT_PERSIST	PS and ALS interrupt persist settings	0x00
0x90	RW	GS_LED	GS LED settings	0x70
0x91	RW	GS_WAIT	GS wait time settings	0x00
0x92	RW	GS_PERSIST	GS interrupt persist settings	0x00
0x93	RW	GS_ENTRY_LSB	GS entry threshold value (1 st entry), LSB	0xFF
0xC3	RW	GS_ENTRY_MSB	GS entry threshold value (1 st entry), MSB	0x07
0x94	RW	GS_EXIT	GS exit threshold value	0x00
0x95	RW	GS_GATE	GS Gate after the 1 st entry	0x00
0x96	RW	GS_XTALK_N	Crosstalk correction on GS North detector	0x00
0x97	RW	GS_XTALK_S	Crosstalk correction on GS South detector	0x00
0x98	RW	GS_XTALK_E	Crosstalk correction on GS East detector	0x00
0x99	RW	GS_XTALK_W	Crosstalk correction on GS West detector	0x00
0x9A	R	PART_ID	Part Number ID and revision IDs	0xC1
0x9B	R	MANUFACT_ID	Manufacturer ID	0x05
0x9C	R	ALS_STATUS	ALS new data status	0x00
0x9D	R	PS_STATUS	PS new data status	0x00

**OPTICAL SENSOR
LTR-91400**

0x9E	R	GS_STATUS	GS new data status	0x00
0xA0 ~ 0xA3	R	RESERVED	RESERVED	0x00
0xA4	R	ALS_CH0_LSB	ALS measurement CH0 data, LSB	0x00
0xA5	R	ALS_CH0_MSB	ALS measurement CH0 data, MSB	0x00
0xA6	R	ALS_CH1_LSB	ALS measurement CH1 data, LSB	0x00
0xA7	R	ALS_CH1_MSB	ALS measurement CH1 data, MSB	0x00
0xA8 – 0xAF	R	RESERVED	RESERVED	0x00
0xB0	R	PS_DATA_LSB	PS measurement data, LSB	0x00
0xB1	R	PS_DATA_MSB	PS measurement data, MSB	0x00
0xB2	R	GS_FIFO_ADDR	GS FIFO address pointer	0x00
0xB3	R	GS_FIFO_ACCESS_N	GS North data	0x00
0xB4	R	GS_FIFO_ACCESS_S	GS South data	0x00
0xB5	R	GS_FIFO_ACCESS_E	GS East data	0x00
0xB6	R	GS_FIFO_ACCESS_W	GS West data	0x00

6.1. ALS_CTRL Register (Address: 0x80) (Read/Write)

The ALS_CTRL register controls ALS operation modes as well as the soft (SW) reset for the whole chip. At any mode (stand-by or active), the I²C circuitry is always active.

0x80	ALS_CTRL (default = 0x00)							
	Bit 7	Bit 6	Bit 5	Bit 4	Bit 3	Bit 2	Bit 1	Bit 0
	<i>Reserved</i>		<i>ALS_INT</i>	<i>ALS_GAIN</i>			<i>SW_RST</i>	<i>ALS_MODE</i>

Field	Bits	Default	Description	
Reserved	7:6	00	--	
ALS_INT	5	0	0	Disable (default)
			1	Enable
ALS_GAIN	4:2	000	000	Gain 1X (default)
			001	Gain 4X
			010	Gain 16X
			011	Gain 64X
			100	Gain 128X
			101	Gain 256X
			11X	Reserved
SW_RST	1	0	Reset registers to default values, with sensor into standby mode.	
			0	No action (default)
			1	Reset Registers to default values
ALS_MODE	0	0	0	Stand-by mode (default)
			1	Active mode

6.2. PS_CTRL Register (Address: 0x81) (Read/Write)

This register controls the Proximity Sensor (PS) operation modes.

0x81	PS_CTRL (default = 0x40)							
	Bit 7	Bit 6	Bit 5	Bit 4	Bit 3	Bit 2	Bit 1	Bit 0
	<i>NEAR/FAR_ Status_EN</i>	<i>Reserved</i>		<i>PS_Offset _EN</i>	<i>PS_GAIN</i>		<i>PS_MODE</i>	<i>PS_INT</i>

OPTICAL SENSOR LTR-91400

Field	Bits	Default	Description	
NEAR / FAR_Status_EN	7	0	0	Disable NEAR/FAR Status reporting (default)
			1	Enable NEAR/FAR Status reporting
Reserved	6:5	10	--	--
PS_Offset_EN	4	0	For crosstalk correction feature. When enabled, PS DATA will be subtracted with PS_XTALK register data.	
			0	Disabled (default)
			1	Enabled
PS_GAIN	3:2	00	00	X1 (default)
			01/10/11	Reserved
PS_MODE	1	0	0	Stand-by mode (default)
			1	Active mode
PS_INT	0	0	0	Disable (default)
			1	Enable

6.3. GS_CTRL Register (Address: 0x82) (Read/Write)

This register controls the Gesture Sensor (GS) operation modes.

0x82	GS_CTRL (default = 0x00)							
	Bit 7	Bit 6	Bit 5	Bit 4	Bit 3	Bit 2	Bit 1	Bit 0
	<i>Reserved</i>	<i>GS_Force Start</i>	<i>GS_FIFO Reset</i>	<i>GS_Offset_EN</i>	<i>GS_GAIN</i>		<i>GS_MODE</i>	<i>GS_INT</i>

Field	Bits	Default	Description	
Reserved	7	0	--	
GS_Force Start	6	0	0	GS force start disable (based on threshold setting at register address 0x93)
			1	GS force start enable (ignore threshold value)
GS_FIFO Reset	5	0	0	FIFO not reset
			1	FIFO reset
GS_Offset_EN	4	0	For crosstalk correction feature. When enabled, GS DATA will be subtracted with GS_XTALK register data.	
			0	Disabled (default)
			1	Enabled
GS_GAIN	3:2	00	00	X1 (default)
			01/10/11	Reserved
GS_MODE	1	0	0	Stand-by mode (default)
			1	Active mode
GS_INT	0	0	0	Disable (default)
			1	Enable

6.4. ALS_MEAS_RATE Register (Address: 0x83) (Read/Write)

This register controls the integration time and timing of the periodic measurement of the ALS in active mode.

0x83	ALS_MEAS_RATE (default = 0x0B)							
	Bit 7	Bit 6	Bit 5	Bit 4	Bit 3	Bit 2	Bit 1	Bit 0
	Reserved			ALS Integration Time		ALS Measurement Rate		

Field	Bits	Default	Description
Reserved	7:5	000	--
ALS Integration Time	4:3	01	00 50ms
			01 100ms (default)
			10 200ms
			11 400ms
ALS Measurement Rate	2:0	011	000 50ms
			001 100ms
			010 200ms
			011 400ms (default)
			1XX 800ms

6.5. ALS_THRES_UP Registers (Address: 0x84 ~ 0x85) (Read/Write)

These registers are used to set the upper limit of the interrupt threshold for ALS. Interrupt functions compare the value in the ALS_THRES_UP registers to the measured data in the ALS_DATA register. The data format should be the same as that of ALS_DATA register.

Field	Register	Default	Description
ALS_THRES_UP_LSB	0x84	1111 1111	ALS least significant byte of the upper interrupt threshold, bit 0 is the LSB of the 16-bit data
ALS_THRES_UP_MSB	0x85	1111 1111	ALS most significant byte of the upper interrupt threshold, bit 7 is the MSB of the 16-bit data

6.6. ALS_THRES_LOW Register (Address: 0x86 ~ 0x87) (Read/Write)

These registers are used to set the lower limit of the interrupt threshold for ALS. Interrupt functions compare the value in the ALS_THRES_LOW registers to the measured data in the ALS_DATA register. The data format should be the same as that of ALS_DATA register.

OPTICAL SENSOR LTR-91400

Field	Register	Default	Description
ALS_THRES_LOW_LSB	0x86	0000 0000	ALS least significant byte of the lower interrupt threshold, bit 0 is the LSB of the 16-bit data
ALS_THRES_LOW_MSB	0x87	0000 0000	ALS most significant byte of the lower interrupt threshold, bit 7 is the MSB of the 16-bit data

6.7. PS_LED Register (Address: 0x88) (Read/Write)

This register sets the PS LED Boost and the Drive Strength.

0x88	PS_LED (default = 0x70)							
	Bit 7	Bit 6	Bit 5	Bit 4	Bit 3	Bit 2	Bit 1	Bit 0
	<i>Reserved</i>				<i>PLED_BOOST</i>		<i>PLED_DRIVE</i>	

Field	Bits	Default	Description	
Reserved	7:4	0111	Must write 0101	
PLED_BOOST	3:2	00	00	1x (default)
			01	1.5x
			10	2x
			11	3x
PLED_DRIVE	1:0	00	00	100mA (default)
			01	50mA
			10	25mA
			11	12.5mA

6.8. PS_MEAS_RATE Register (Address: 0x89) (Read/Write)

This register controls PS measurement time and number of PS LED Pulses.

0x89	PS_MEAS_RATE (default = 0x40)							
	Bit 7	Bit 6	Bit 5	Bit 4	Bit 3	Bit 2	Bit 1	Bit 0
	PS Measurement Time			<i>Reserved</i>	PS number of LED pulses			

Field	Bits	Default	Description	
PS Measurement Time	7:5	010	000	6.125ms
			001	50ms
			010	100ms (default)
			011	200ms
			100	400ms
			101	800ms

**OPTICAL SENSOR
LTR-91400**

			110	12.5ms
			111	25ms
Reserved	4	0	Must write 1	
PS number of LED pulses	3:0	0000	Specifies PS LED number of pulses. If PS number of pulse set to 0, the pulse count will be 1	

6.9. PS_XTALK_NE Registers (Address: 0x8B, 0xCB) (Read/Write)

These registers provide crosstalk correction on PS North+East detectors pair.

Field	Register	Default	Description
PS_XTALK_NE_LSB	0x8B	0000 0000	PS North+East Data will subtract this value, LSB
PS_XTALK_NE_MSB	0xCB	000	PS North+East Data will subtract this value, MSB.

6.10. PS_XTALK_SW Registers (Address: 0x8C, 0xCC) (Read/Write)

These registers provide crosstalk correction on PS South+West detectors pair.

Field	Register	Default	Description
PS_XTALK_SW_LSB	0x8C	0000 0000	PS South+West Data will subtract this value, LSB.
PS_XTALK_SW_MSB	0xCC	000	PS South+West Data will subtract this value, MSB.

6.11. PS_THRES_UP Register (Address: 0x8D, 0xCD) (Read/Write)

This register is used to set the upper limit of the absolute interrupt threshold value. Interrupt functions compare the value in the PS_THRES_UP registers to measured data value in PS_DATA registers. The data format for PS_THRES_UP must be the same as that of PS_DATA registers.

Field	Register	Default	Description
PS_THRES_UP_LSB	0x8D	1111 1111	PS upper interrupt threshold value, LSB
PS_THRES_UP_MSB	0xCD	111	PS upper interrupt threshold value, MSB

6.12. PS_THRES_LOW Register (Address: 0x8E, 0xCE) (Read/Write)

This register is used to set the lower limit of the absolute interrupt threshold value. Interrupt functions compare the value in the PS_THRES_LOW registers to measured data value in PS_DATA registers. The data format for PS_THRES_LOW must be the same as that of PS_DATA registers.

Field	Register	Default	Description
PS_THRES_LOW_LSB	0x8E	0000 0000	PS lower interrupt threshold value, LSB

**OPTICAL SENSOR
LTR-91400**

PS_THRES_LOW_MSB	0xCE	000	PS lower interrupt threshold value, MSB
------------------	------	-----	---

6.13. INTERRUPT PERSIST Register (Address: 0x8F) (Read/Write)

This register sets the N number of times the measurement is out of the threshold range settings before asserting the INTERRUPT pin.

0x8F	INTERRUPT PERSIST (default = 0x00)							
	Bit 7	Bit 6	Bit 5	Bit 4	Bit 3	Bit 2	Bit 1	Bit 0
	<i>PS_PERSIST</i>				<i>ALS_PERSIST</i>			

Field	Bits	Default	Description	
PS_PERSIST	7:4	0000	0000	Every PS value out of threshold range (default)
			0001	1 consecutive PS values out of threshold range
		
			1111	15 consecutive PS values out of threshold range
ALS_PERSIST	3:0	0000	0000	Every ALS value out of threshold range (default)
			0001	1 consecutive ALS values out of threshold range
		
			1111	15 consecutive ALS values out of threshold range

6.14. GS_LED Register (Address: 0x90) (Read/Write)

This register sets the GS LED Boost and the Drive Strength.

0x90	GS_LED (default = 0x70)							
	Bit 7	Bit 6	Bit 5	Bit 4	Bit 3	Bit 2	Bit 1	Bit 0
	<i>Reserved</i>				<i>GLED_BOOST</i>		<i>GLED_DRIVE</i>	

Field	Bits	Default	Description	
Reserved	7:4	0111	Must write 0101	
GLED_BOOST	3:2	00	00	1x (default)
			01	1.5x
			10	2x
			11	3x
GLED_DRIVE	1:0	00	00	100mA (default)
			01	50mA
			10	25mA
			11	12.5mA

6.15. GS_WAIT Register (Address: 0x91) (Read/Write)

This register controls GS wait time and number of GS LED Pulses.

0x91	GS_WAIT (default = 0x00)							
	Bit 7	Bit 6	Bit 5	Bit 4	Bit 3	Bit 2	Bit 1	Bit 0
	Reserved		GS Wait Time		GS Number of LED pulses			

Field	Bits	Default	Description	
Reserved	7	0	--	
GS Wait Time	6:4	000	000	0ms (default)
			001	2ms
			010	4ms
			011	6ms
			100	10ms
			101	14ms
			110	18ms
			111	22ms
GS Number of LED pulses	3:0	0000	Specifies GS LED number of pulses. If GS number of pulse set to 0, the pulse count will be 1.	

6.16. GS_PERSIST Register (Address: 0x92) (Read/Write)

This register set the occurrence of gesture exit.

0x92	GS_PERSIST (default = 0x00)							
	Bit 7	Bit 6	Bit 5	Bit 4	Bit 3	Bit 2	Bit 1	Bit 0
	Reserved				GS_PERSIST		Reserved	

Field	Bits	Default	Description	
Reserved	7:4	0000	--	
GS PERSIST	3:2	00	00	1 st gesture exit occurrence will exit gesture detections.
			01	2 nd gesture exit occurrence will exit gesture detections.
			10	3 rd gesture exit occurrence will exit gesture detections.
			11	4 th gesture exit occurrence will exit gesture detections.
Reserved	1:0	00	--	

6.17. GS_ENTRY Register (Address: 0x93, 0xC3) (Read/Write)

This register compares with Proximity value PS_DATA, to determine if were to enter the gesture integration. GS_ENTRY to be greater than Xtalk level. Example: Xtalk = 100, set GS_ENTRY = 150.

Setting GS_Entry to 0x00 will force sensor to enter gesture integration as long as GS_MODE is enabled.

Please refer to GS state machine (Page 28) for more details.

Field	Register	Default	Description
GS_ENTRY_LSB	0x93	1111 1111	GS entry threshold value, LSB
GS_ENTRY_MSB	0xC3	111	GS entry threshold value, MSB

6.18. GS_EXIT Register (Address: 0x94) (Read/Write)

This register compares with Gesture value to determine if were to exit the gesture integration.

Please refer to GS state machine (Page 28) for more details.

Field	Register	Default	Description	
GS_EXIT	0x94	0000 0000	GS exit threshold value.	
			0xFF	Prevent gesture event detection
			GS exit threshold value. Recommended to be same level to GS entry threshold value. Example: GS_EXIT = GS_ENTRY
			0x00	Force sensor to complete 32 GS datasets. (default)

6.19. GS_GATE Register (Address: 0x95) (Read/Write)

After entry threshold (value in GS_ENTRY) is exceeded, this register provides additional gate before final entry into the GS machine. This register is the threshold value of considering there is a gesture event when the absolute delta count of either W-E or N-S exceeding the threshold value.

Field	Register	Default	Description	
GS_GATE	0x95	0000 0000	GS threshold value.	
			0xFF	Prevent gesture event detection
			GS threshold value.
			0x00	Always trigger gesture event even if there is no gesture event. (default)

6.20. GS_XTALK Registers (Address: 0x96 ~ 0x99) (Read/Write)

These registers provide crosstalk correction for the detectors.

Field	Register	Default	Description
GS_XTALK_N	0x96	0000 0000	GS North Data will subtract this value.
GS_XTALK_S	0x97	0000 0000	GS South Data will subtract this value.
GS_XTALK_E	0x98	0000 0000	GS East Data will subtract this value.
GS_XTALK_W	0x99	0000 0000	GS West Data will subtract this value.

6.21. PART_ID Register (Address: 0x9A) (Read Only)

This register defines the part number of the device.

0x9A	PART_ID (default = 0xC1)							
	Bit 7	Bit 6	Bit 5	Bit 4	Bit 3	Bit 2	Bit 1	Bit 0
	<i>Part ID</i>				<i>Reserved</i>			

Field	Bits	Default	Description
Part ID	7:4	1100	Part Number ID
Reserved	3:0	0001	--

6.22. MANUFACT_ID Register (Address: 0x9B) (Read Only)

This register defines the manufacturer identification.

Field	Register	Default	Description
MANUFACT_ID	0x9B	05H	Manufacturer ID

OPTICAL SENSOR LTR-91400

6.23. ALS_STATUS Register (Address: 0x9C) (Read Only)

This register stores information about ALS interrupt status as well as ALS data status.

0x9C	ALS_STATUS (default = 0x00)							
	Bit 7	Bit 6	Bit 5	Bit 4	Bit 3	Bit 2	Bit 1	Bit 0
	<i>Reserved</i>		<i>ALS Data Valid</i>	<i>ALS Data Gain Range</i>			<i>ALS Interrupt Status</i>	<i>ALS Data Status</i>

Field	Bits	Default	Description	
Reserved	7:6	00	--	
ALS Data Valid	5	0	0	ALS Data is Valid (default)
			1	ALS Data is Invalid
ALS Data Gain Range	4:2	000	000	Gain 1X (default)
			001	Gain 4X
			010	Gain 16X
			011	Gain 64X
			100	Gain 128X
			101	Gain 256X
			11X	Reserved
			ALS Interrupt Status	1
1	Interrupt signal ACTIVE			
ALS Data Status	0	0	0	OLD data (data already read), (default)
			1	NEW data (first time data is read)

6.24. PS_STATUS Register (Address: 0x9D) (Read Only)

This register stores information about PS interrupt status as well as PS data status.

0x9D	PS_STATUS (default = 0x00)							
	Bit 7	Bit 6	Bit 5	Bit 4	Bit 3	Bit 2	Bit 1	Bit 0
	<i>Reserved</i>			<i>NEAR_Status</i>	<i>FAR_Status</i>	<i>PS Data Valid</i>	<i>PS Interrupt Status</i>	<i>PS Data Status</i>

Field	Bits	Default	Description	
Reserved	7:5	000	--	
NEAR_Status	4	0	0	Not detecting object (default)
			1	Object is near (PS count > high threshold)
FAR_Status	3	0	0	Not detecting object (default)
			1	Object is far (PS count < low threshold)
PS Data Valid	2	0	0	PS Data is Valid (default)
			1	PS Data is Invalid
PS Interrupt	1	0	0	Interrupt signal INACTIVE (default)

OPTICAL SENSOR LTR-91400

Status			1	Interrupt signal ACTIVE
PS Data Status	0	0	0	OLD data (data already read), (default)
			1	NEW data (first time data is read)

6.25. GS_STATUS Register (Address: 0x9E) (Read Only)

This register stores information about GS_FIFO, GS interrupt status as well as GS data status.

Please refer to GS state machine (Page 28) for more details.

0x9E	GS_STATUS (default = 0x00)							
	Bit 7	Bit 6	Bit 5	Bit 4	Bit 3	Bit 2	Bit 1	Bit 0
	<i>GS_FIFO Empty</i>	<i>GS_FIFO Full</i>	<i>GS Data Valid</i>	<i>GS Interrupt Status</i>	<i>GS Data Status</i>	<i>Reserved</i>		

Field	Bits	Default	Description	
GS_FIFO Empty	7	0	0	GS FIFO is empty (default)
			1	GS FIFO is not empty
GS_FIFO Full	6	0	0	GS FIFO is not full (default)
			1	GS FIFO is full.
GS Data Valid	5	0	0	GS Data is Valid (default)
			1	GS Data is Invalid
GS Interrupt Status	4	0	0	Interrupt signal INACTIVE (default)
			1	Interrupt signal ACTIVE
GS Data Status	3	0	0	OLD data (data already read), (default)
			1	NEW data (first time data is read)
Reserved	2:0	000	--	

6.26. ALS_DATA Registers (Address: 0xA4 ~ 0xA7) (Read Only)

These registers store ALS Channel measurement results.

Field	Address	Bits	Description
ALS_CH0_LSB	0xA4	0000 0000	ALS CH0 low byte data, bit 0 is LSB of the 16-bit data
ALS_CH0_MSB	0xA5	0000 0000	ALS CH0 high byte data, bit 7 is MSB of the 16-bit data
ALS_CH1_LSB	0xA6	0000 0000	ALS CH1 low byte data, bit 0 is LSB of the 16-bit data
ALS_CH1_MSB	0xA7	0000 0000	ALS CH1 high byte data, bit 7 is MSB of the 16-bit data

6.27. PS_DATA Register (Address: 0xB0, 0xB1) (Read Only)

This register stores 11-bits PS measurement results.

Field	Register	Default	Description
PS_Data_LSB	0xB0	0000 0000	PS measurement data, LSB.
PS_Data_MSB	0xB1	000	PS measurement data, MSB.

6.28. GS_FIFO_ADDR Register (Address: 0xB2) (Read Only)

This register defines GS_FIFO address pointer, to indicate how many four-byte dataset are remaining for read over I2C. Every dataset read will decrement this pointer by 1. After finish reading, this pointer will become zero and interrupt will be cleared. Then, IC will automatically start the next GS motion detection.

0xB2	GS_FIFO_ADDR (default = 0x00)							
	Bit 7	Bit 6	Bit 5	Bit 4	Bit 3	Bit 2	Bit 1	Bit 0
	<i>Reserved</i>		<i>GS_FIFO_ADDR</i>					

Field	Address	Default	Description
Reserved	7:6	00	--
GS_FIFO_ADDR	5:0	000000	GS FIFO address pointer. This register indicates how many 4-bytes dataset is still not read in GS FIFO.

6.29. GS_FIFO_ACCESS Registers (Address: 0xB3 ~ 0xB6) (Read only)

These registers define GS_FIFO data access registers. These registers are to be read sequentially from 0xB3 to 0xB6, and repeat the sequence for the next dataset.

Field	Register	Default	Description
GS_NDATA	0xB3	0000 0000	GS North directional data
GS_SDATA	0xB4	0000 0000	GS South directional data
GS_EDATA	0xB5	0000 0000	GS East directional data
GS_WDATA	0xB6	0000 0000	GS West directional data

7. Application Information

7.1. ALS Lux Conversion

Lux_Calc is the calculated lux reading. Ch0 and Ch1 is the digital representation (output ADC) of ambient light level stored in the registers (Address: 0xA4-0xA7) regardless of light sources. Table 1 shows the scale factors at different ALS Range and Integration Time:

General Lux equation,

$$Lux_Calc = \frac{(WF \times 0.6)}{(GAIN \times INT)} \times [Ch0 - (IRFac \times Ch1)]$$

Simplified equation based on clear window,

$$Lux_Calc = \frac{0.6}{(GAIN \times INT)} \times Ch0$$

Where,

Window Factor, **WF = 1**

IR Factor, **IRFac = 0**

ALS Gain	GAIN
X1	1
X4	4
X16	16
X64	64
X128	128
X256	256

ALS Integration Time (ms)	INT
100	1
200	2
300	3
400	4

Table 1

Note: The WF and IRfac will need to be derived if window is being used.

7.2. State Machine

Below diagram illustrates the LTR-91400 top level state machine operation.

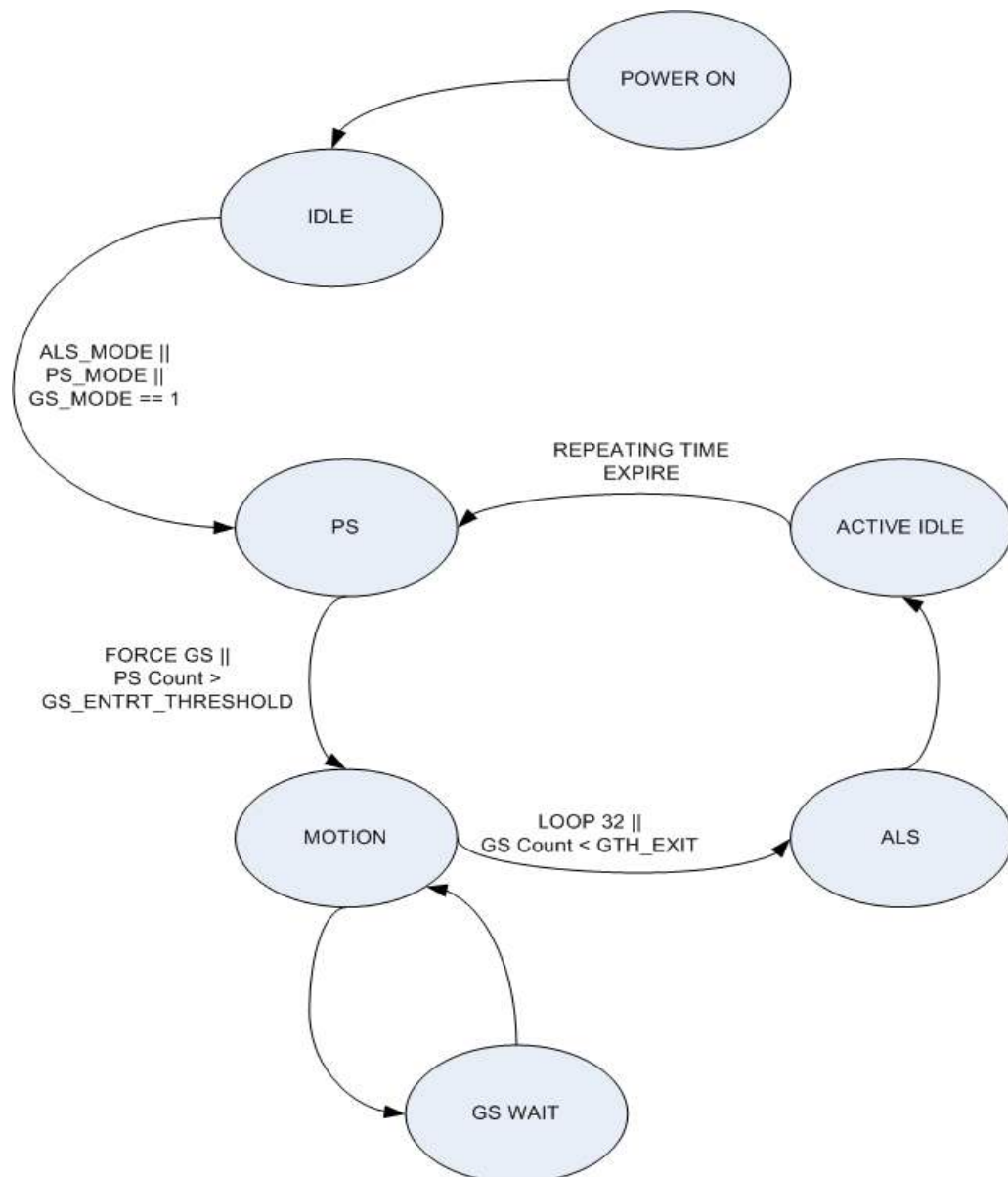

Flow Diagram 1.1 : LTR-91400 top level state machine operation.

OPTICAL SENSOR LTR-91400

Below illustrates the LTR-91400 details state machine operation on Gesture Mode enabling.

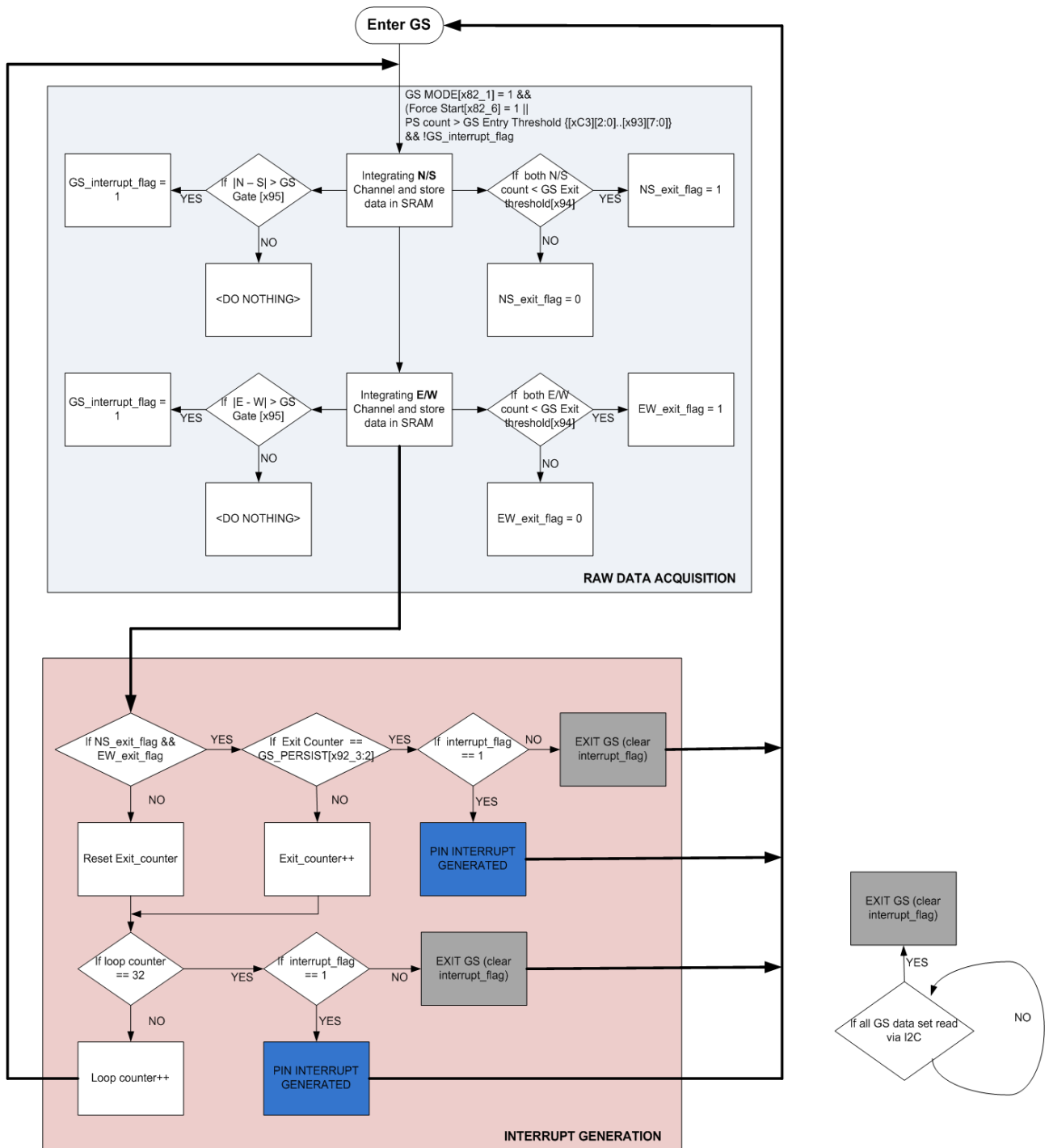

7.3. Operating modes

Stand-by Mode

The device is by default in stand-by mode after power-up. No measurement activity done in either ALS, PS or GS. I²C communication is allowed to be able to read/write to the registers. The device can be reset from MCU by setting appropriate register control (SW reset). Start-up sequence is exactly the same as that when power-on reset is triggered.

Active Mode

The ALS and PS can only run in active mode **sequentially**. Measurement data is expected to be available within a known fixed time. Below illustrates ALS and PS measurement sequence.

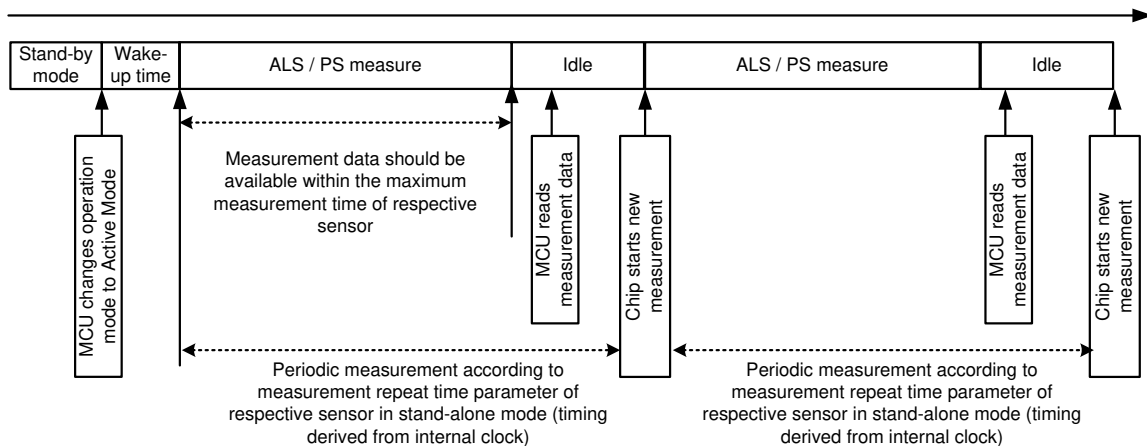

NOTE: If repeating rate smaller than measurement/integration time, measurement will repeat according to measurement time.

Below illustrates GS measurement sequence.

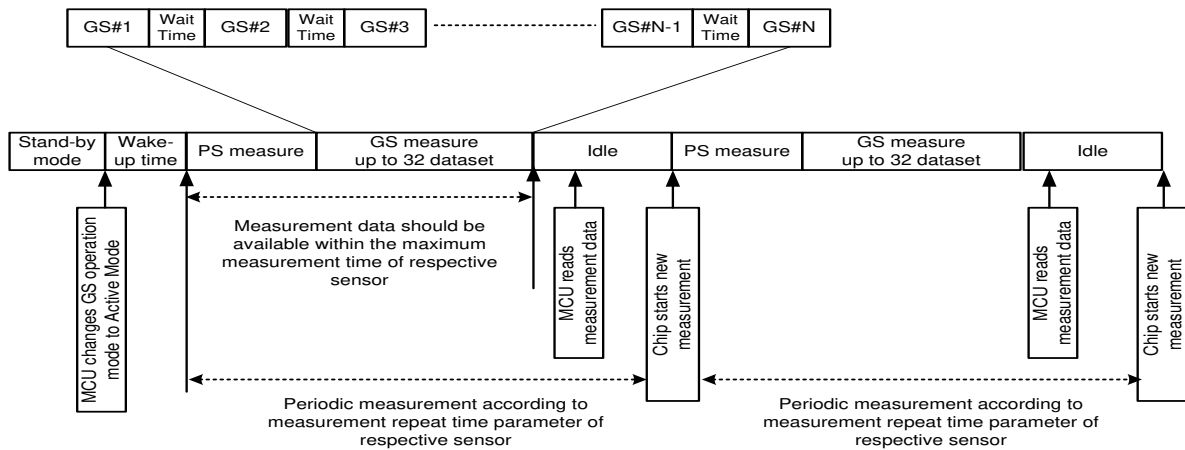

NOTE: If repeating rate smaller than measurement/integration time, measurement will repeat according to measurement time.

N = number of dataset.

N is up to 32 dataset or lower if GS exit threshold is met.

7.4. Interrupt Features

Interrupt function is active if ALS or PS measurements are outside of the upper and lower absolute threshold levels set in the appropriate threshold register. Only newly measured data is compared to the threshold levels set such that old data will not cause triggering of the INT pin if in case the threshold levels are changed in between measurements.

The status of interrupt can be monitored directly through the interrupt (INT) pin or by checking contents of the interrupt register. Interrupt pin can either be enabled or disabled.

The status of the ALS and PS interrupt pin/register is updated after each measurement cycle. It will reset back when corresponding data register is read or new data is out of threshold range, whichever come first.

The status of the GS interrupt/pin register once triggered will keep its value unless data from the SRAM is flushed out by the user. Latest GS data will be discarded if SRAM is full.

Interrupt pin IO requirements are exactly the same as those of the I2C bus pins SDA and SCL.

**OPTICAL SENSOR
LTR-91400**

Below is the Interrupt pin illustration for absolute threshold on default setting.

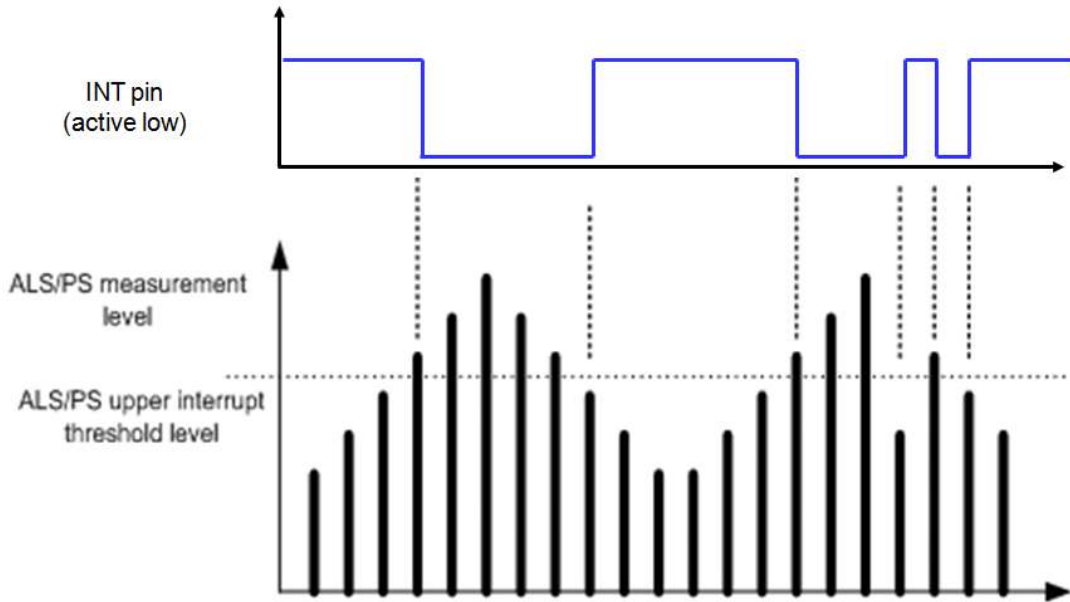

Below is the Interrupt pin illustration for absolute threshold with enabling NTF/FTN_Status reporting in register address 0x81 [bit 7].

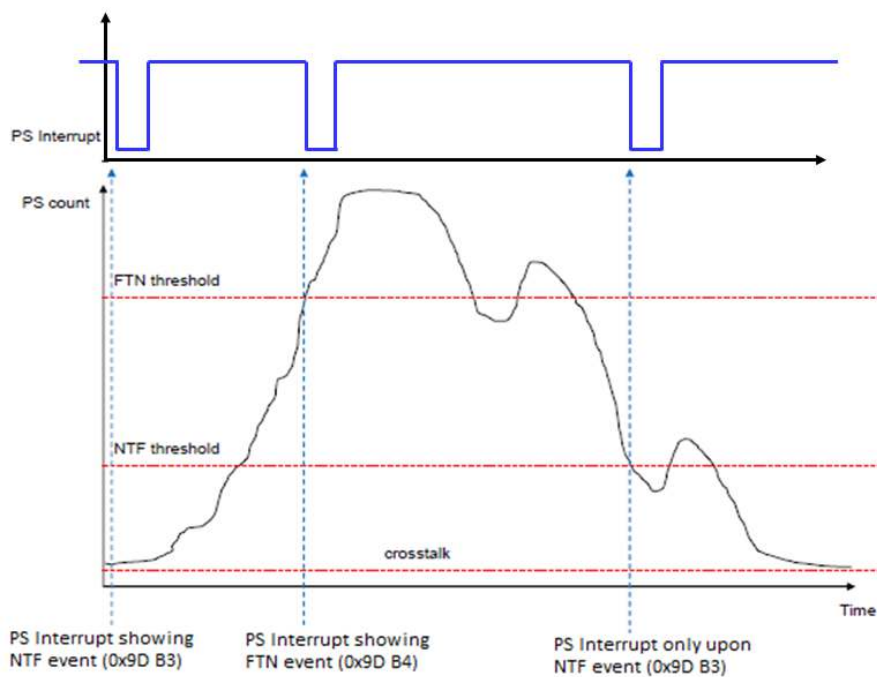

8. Pseudo Codes Examples

SLAVE Addresses

```
Slave_Addr = 0x23 // Slave address
```

ALS_CTRL Register

// This defines the operating modes of the ALS. Default setting is 0x00 in Standby mode.

```
Register_Addr = 0x80 // ALS_CTRL register
Command = 0x01 // ALS in Active Mode
// ALS in Active Mode, ALS Interrupt Enable, Command = 0x21
WriteByte(Slave_Addr, Register_Addr, Command);
```

ALS_MEAS_RATE Register

// This controls the ALS integration time and measurement rate.
// Default setting of the register is 0x0B (Integration time 100ms and Measurement rate of 400ms)

```
Register_Addr = 0x83 // ALS_MEAS_RATE register
Command = 0x0B // Integration 100ms, Measurement rate =400ms
// For Integration tme = 400ms, Meas rate =800ms, Command =0x1C
// For Integration tme = 100ms, Meas rate =800ms, Command =0x0C
WriteByte(Slave_Addr, Register_Addr, Command)
```

ALS_THRES Registers

// The ALS_THRES_UP and ALS_THRES_LOW registers determine the upper and lower limits
// of the interrupt threshold value.
// Following example illustrates the settings of the ALS threshold window of decimal values of
// 1000 (upper threshold) and 200 (lower threshold)

```
// Set ALS Upper threshold for Interrupt, example 1000 (decimal)
Data1 = 1000 >> 8 // To convert decimal 1000 into two eight bytes register values
Data0 = 1000 & 0xFF
Register_Addr = 0x84 // ALS_THRES_UP_0 Register address
WriteByte(Slave_Addr, Register_Addr, Data0)
Register_Addr = 0x85 // ALS_THRES_UP_1 Register address
WriteByte(Slave_Addr, Register_Addr, Data1)
```

```
// Set ALS Lower threshold for Interrupt, example 200 (decimal)
Data1 = 200 >> 8 // To convert decimal 200 into two eight bytes register values
Data0 = 200 & 0xFF
```

```
Register_Addr = 0x86 // ALS_THRES_LOW_0 Register address
WriteByte(Slave_Addr, Register_Addr, Data0)
Register_Addr = 0x87 // ALS_THRES_LOW_1 Register address
WriteByte(Slave_Addr, Register_Addr, Data1)
```

ALS_STATUS Register (Read Only)

// This Register contains the information on ALS Data valid, ALS Interrupt and ALS data status.

```
Register_Addr = 0x9C // ALS_STATUS register address
Data = ReadByte(Slave_Addr, Register_Addr)

ALS_Data_Valid = Data & 0x20 // If 0x20 ALS Data is invalid (discard)
// If 0x00 ALS Data is valid (usable)
```

OPTICAL SENSOR LTR-91400

ALS_Interrupt_Status = Data & 0x02 // If 0x02 ALS Interrupt condition fulfilled
 // If 0x00 ALS Interrupt condition not fulfilled

ALS_Data_Status = Data & 0x01 // If 0x01 New Data
 // If 0x00 Old (previously read) Data

ALS_CH0 DATA Registers (Read Only)

// The register 0xA4 contains ALS_CH0_Data lower byte data.
 // The register 0xA5 contains ALS_CH0_Data upper byte data.
 // These registers should be read as a group, with the lower address being read first.

Register_Addr = 0xA4 // ALS_CH0 DATA lower byte address
 Data1=ReadByte(Slave_Addr, Register_Addr)
 Register_Addr = 0xA5 // ALS_CH0 DATA upper byte address
 Data2=ReadByte(Slave_Addr, Register_Addr)

ALS_CH0_Data = (Data2 << 8) | Data1 // Combining lower and upper bytes to give 16-bit ALS_CH0 data

ALS_CH1 DATA Registers (Read Only)

// The register 0xA6 contains ALS_CH1_Data lower byte data.
 // The register 0xA7 contains ALS_CH1_Data upper byte data.
 // These registers should be read as a group, with the lower address being read first.

Register_Addr = 0xA6 // ALS_CH1 DATA lower byte address
 Data1=ReadByte(Slave_Addr, Register_Addr)
 Register_Addr = 0xA7 // ALS_CH1 DATA upper byte address
 Data2=ReadByte(Slave_Addr, Register_Addr)

ALS_CH1_Data = (Data2 << 8) | Data1 // Combining lower and upper bytes to give 16-bit ALS_CH1 data

PS_CTRL Register

// This defines the operating modes of the PS. Default settings is 0x00 in Standby mode.

Register_Addr = 0x81 // PS_CTRL register
 Command = 0x02 // PS in Active Mode
 // PS in Active Mode, Enable PS Interrupt, Command = 0x03
 WriteByte(Slave_Addr, Register_Addr, Command);

PS_LED Register

// This defines the PS LED Pulse Duty, Pulse width, Boost and Drive Strength.
 // Default setting of the register is 0x70

Register_Addr = 0x88 // PS_LED register
 Command = 0x50 // Pulse Duty=25%, Pulse Width=8us, Drive=100mA
 WriteByte(Slave_Addr, Register_Addr, Command)

PS_MEAS_RATE Register

// This controls the PS measurement rate.
 // Default setting of the register is 0x40

Register_Addr = 0x89 // PS_MEAS_RATE register
 Command = 0x52 // Meas Rate = 100ms, PS 11 Bit , LED =2 pulses
 WriteByte(Slave_Addr, Register_Addr, Command)

PS_THRES_UP Registers

// PS_THRES_UP registers determines the upper limit of the interrupt threshold value
 // Register 0x8D sets PS Interrupt upper limit, lower byte data (PS_THRES_UP_LSB)
 // Register 0xCD sets PS Interrupt upper limit, 3 bits of upper byte data (PS_THRES_UP_MSB)
 // These registers should be read as a group, with the lower address being read first.

// Following example illustrates the setting of the PS dynamic threshold with hysteresis interruption for
 // decimal value 200 (for NEAR detection)

```
Upper_Threshold_Value=200           // Example 200 (decimal)
Data1 = Upper_Threshold_Value >> 8 // Shift right to extract the upper byte
Data0 = Upper_Threshold & 0xFF      // Mask to extract lower byte.

Register_Addr = 0x8D                // PS_THRES_UP_LSB Register address
WriteByte(Slave_Addr, Register_Addr, Data0)
Register_Addr = 0xCD                // PS_THRES_UP_MSB Register address
WriteByte(Slave_Addr, Register_Addr, Data1)
```

PS_THRES_LOW Registers

// PS_THRES_LOW registers determines the lower limit of the interrupt threshold value

// Register 0x8E sets PS Interrupt lower limit, lower byte data (PS_THRES_LOW_LSB)
 // Register 0xCE sets PS Interrupt lower limit, 3 bits of upper byte data (PS_THRES_LOW_MSB)
 // These registers should be read as a group, with the lower address being read first.

// Following example illustrates the setting of the PS dynamic threshold with hysteresis interruption for
 // decimal value 50 (for FAR detection)

```
Lower_Threshold_Value=50           // Example 50 (decimal)
Data1 = Lower_Threshold_Value >> 8 // Shift right to extract the upper byte
Data0 = Lower_Threshold & 0xFF      // Mask to extract lower byte.

Register_Addr = 0x8E                // PS_THRES_LOW_LSB Register address
WriteByte(Slave_Addr, Register_Addr, Data0)
Register_Addr = 0xCE                // PS_THRES_LOW_MSB Register address
WriteByte(Slave_Addr, Register_Addr, Data1)
```

PS_STATUS Register (Read Only)

// This Register contains the information on FTN, NTF, PS Data valid, PS Interrupt and PS data status.

```
Register_Addr = 0x9D                // PS_STATUS register address
Data = ReadByte(Slave_Addr, Register_Addr)

FTN = Data & 0x10                   // If 0x10 FTN object detected
                                     // If 0x00 FTN object not detected

NTF = Data & 0x08                   // If 0x08 NTF object detected
                                     // If 0x00 NTF object not detected

PS_Data_Valid = Data & 0x04         // If 0x04 PS Data is invalid (discard)
                                     // If 0x00 PS Data is valid (usable)

PS_Interrupt_Status = Data & 0x02  // If 0x02 PS Interrupt condition fulfilled
                                     // If 0x00 PS Interrupt condition not fulfilled

PS_Data_Status = Data & 0x01       // If 0x01 New Data
                                     // If 0x00 Old (previously read) Data
```

PS_DATA Registers (Read Only)

//The register 0xB0 contains PS_Data lower byte data.
 //The register 0xB1 contains PS_Data 3 bits of upper byte data
 //These registers should be read as a group, with the lower address being read first.

Register_Addr = 0xB0 // PS_DATA lower byte address
 Data0=ReadByte(Slave_Addr, Register_Addr)

Register_Addr = 0xB1 // PS_DATA upper byte address
 Data=ReadByte(Slave_Addr, Register_Addr)
 Data1=Data&0x03 // Mask with 0x03 to extract data

PS_Data = (Data1 << 8) | Data0 // Shift and combine lower and upper bytes to give 11-bit PS data

GS_CTRL Register

// This defines the operating modes of the GS. Default setting is 0x00 in Standby mode.

Register_Addr = 0x82 // GS_CTRL register
 Command = 0x02 // GS in Active Mode
 // GS in Active Mode, Enable GS Interrupt, Command = 0x03

WriteByte(Slave_Addr, Register_Addr, Command);

GS_LED Register

// This defines the GS LED Pulse Duty, Pulse Width, Boost and Drive Strength.
 // Default setting is 0x70

Register_Addr = 0x90 // GS_LED register
 Command = 0x50 // Drive=100mA
 // Drive=50mA, Command =0x51

WriteByte(Slave_Addr, Register_Addr, Command)

GS_WAIT Register

// This controls the GS wait time and number of GS LED pulses.
 // Default setting of the register is 0x00 (No wait)

Register_Addr = 0x91 // GS_WAIT register
 Command = 0x00 // Command = 0x00, GS LED pulses =1

WriteByte(Slave_Addr, Register_Addr, Command)

GS_XTALK Register

// This subtracts the register contents from the appropriate detector
 // Default setting of the register is 0x00 (No wait)

Register_Addr = 0x96 // GXTALK_N , North detector
 // Register_Addr = 0x97 GXTALK_S, south
 // Register_Addr = 0x98 GXTALK_E, east
 // Register_Addr = 0x99 GXTALK_W, west

Command = 0x20 // Will subtract 0x20 from North detector
 // thus 0xB3 (GS_NDATA) will have 0x20 less

WriteByte(Slave_Addr, Register_Addr, Command)

GS_ENTRY Registers

//GS_ENTRY compare with PS_DATA, to determine if were to enter the gesture integration.
 //The register 0x93 contains GS_ENTRY lower byte data (GS_ENTRY_LSB)
 //The register 0xC3 contains 3 bits of GS_ENTRY upper byte data (GS_ENTRY_MSB)

//To set GS Entry Value

GS_Entry_Value=100

Data1 = GS_Entry_Value >> 8

// Shift right to extract the upper byte

Data0 = GS_Entry_Value & 0xFF

// Mask to extract lower byte.

Register_Addr = 0x93

// GS_ENTRY_LSB Register address

WriteByte(Slave_Addr, Register_Addr, Data0)

Register_Addr = 0xC3

// GS_ENTRY_MSB Register address

WriteByte(Slave_Addr, Register_Addr, Data1)

GS_EXIT / GS_GATE Registers

// GS_EXIT compare with Gesture value, to determine if were to exit the gesture integration.
 // GS_GATE is the threshold value of considering there is a gesture event when the absolute delta count of
 // either W-E or N-S exceeding the threshold value.

// To set GS Exit value

Register_Addr = 0x94

// GS_EXIT Register address

Command = 0x00

// GS threshold value to EXIT gesture integration

WriteByte(Slave_Addr, Register_Addr, Data)

// To set GS GATE

Register_Addr = 0x95

// GS_THRES Register address

Command = 0x00

// Always trigger gesture event

// Prevent gesture event detection, command = 0xFF

WriteByte(Slave_Addr, Register_Addr, Data)

GS_STATUS Register (Read Only)

// This Register contains the information on GS FIFO, Data, Interrupt and data status.

Register_Addr = 0x9E

// GS_STATUS register address

Data = ReadByte(Slave_Addr, Register_Addr)

GS_FIFO_Empty = Data & 0x80

// If 0x80 GS_FIFO not empty

// If 0x00 GS_FIFO empty

GS_FIFO_Full = Data & 0x40

// If 0x40 GS_FIFO full

// If 0x00 GS_FIFO not full

GS_Data_Valid = Data & 0x20

// If 0x20 GS Data is invalid (discard)

// If 0x00 GS Data is valid (usable)

GS_Interrupt_Status = Data & 0x10

// If 0x10 GS Interrupt condition fulfilled

// If 0x00 GS Interrupt condition not fulfilled

GS_Data_Status = Data & 0x08

// If 0x08 New Data

// If 0x00 Old (previously read) Data

GS_FIFO Registers (Read Only)

// This Register defines GS_FIFO address pointer, NData, SData, EData and WData

Register_Addr = 0xB2 // GS_FIFO_ADDR register address
Data = ReadByte(Slave_Addr, Register_Addr)

Register_Addr = 0xB3 // GS_NDATA register address
Data = ReadByte(Slave_Addr, Register_Addr)

Register_Addr = 0xB4 // GS_SDATA register address
Data = ReadByte(Slave_Addr, Register_Addr)

Register_Addr = 0xB5 // GS_EDATA register address
Data = ReadByte(Slave_Addr, Register_Addr)

Register_Addr = 0xB6 // GS_WDATA register address
Data = ReadByte(Slave_Addr, Register_Addr)

INTERRUPT_PERSIST Register

// This register sets the PS and ALS persist level.

// The default setting is 0x00. Interrupt at every ALS and PS reading outside set thresholds.

Register_Addr = 0x8F // INTERRUPT_PERSIST register
Command = 0x00 // Interrupt for every ALS and PS value outside threshold
// Subsequent 2 ALS and every PS value, outside threshold range, Command=0x01
// Subsequent 2 ALS and PS values, outside threshold range, Command=0x11
// Subsequent 8 ALS and subsequent 11 PS values, outside threshold range, Command=0xA7
// Subsequent 11 ALS and subsequent 8 PS values, outside threshold range, Command=0x7A
WriteByte(Slave_Addr, Register_Addr, Command)

9. Recommended Leadfree Reflow Profile

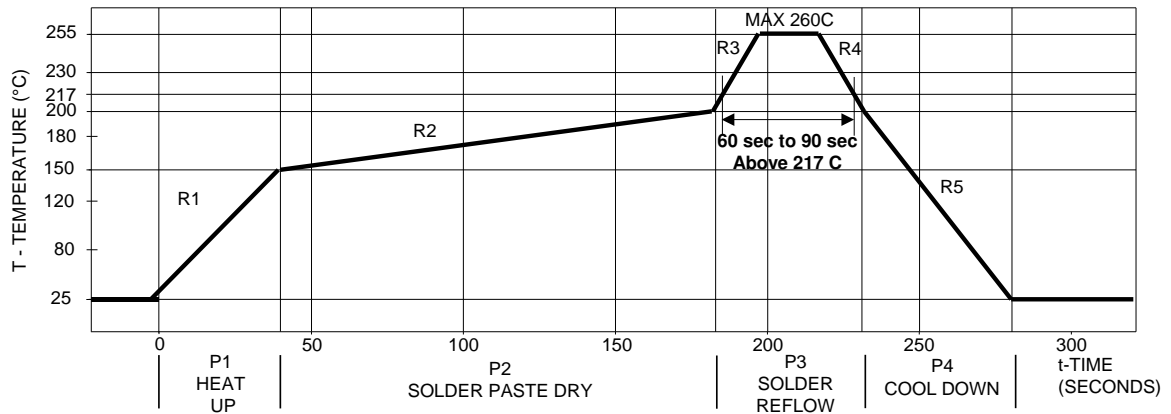

Process Zone	Symbol	ΔT	Maximum $\Delta T/\Delta t$ or Duration
Heat Up	P1, R1	25°C to 150°C	3°C/s
Solder Paste Dry	P2, R2	150°C to 200°C	100s to 180s
Solder Reflow	P3, R3	200°C to 260°C	3°C/s
	P3, R4	260°C to 200°C	-6°C/s
Cool Down	P4, R5	200°C to 25°C	-6°C/s
Time maintained above liquidus point , 217°C		> 217°C	60s to 90s
Peak Temperature		260°C	-
Time within 5°C of actual Peak Temperature		> 255°C	20s
Time 25°C to Peak Temperature		25°C to 260°C	8mins

It is recommended to perform reflow soldering no more than twice.

10. Moisture Proof Packaging

All LTR-91400 are shipped in moisture proof package. Once opened, moisture absorption begins. This part is compliant to JEDEC J-STD-033A Level 3.

10.1. Time from Unsealing to Soldering

After removal from the moisture barrier bag, the parts should be stored at the recommended storage conditions and soldered within seven days. When the moisture barrier bag is opened and the parts are exposed to the recommended storage conditions for more than seven days, the parts must be baked before reflow to prevent damage to the parts.

10.1.1. Recommended Storage Conditions

Storage Temperature	10°C to 30°C
Relative Humidity	Below 60% RH

10.1.2. Baking Conditions

Package	Temperature	Time
In Reels	60°C	48 hours
In Bulk	100°C	4 hours

Baking should only be done once.

11. Recommended Land Pattern and Metal Stencil Aperture

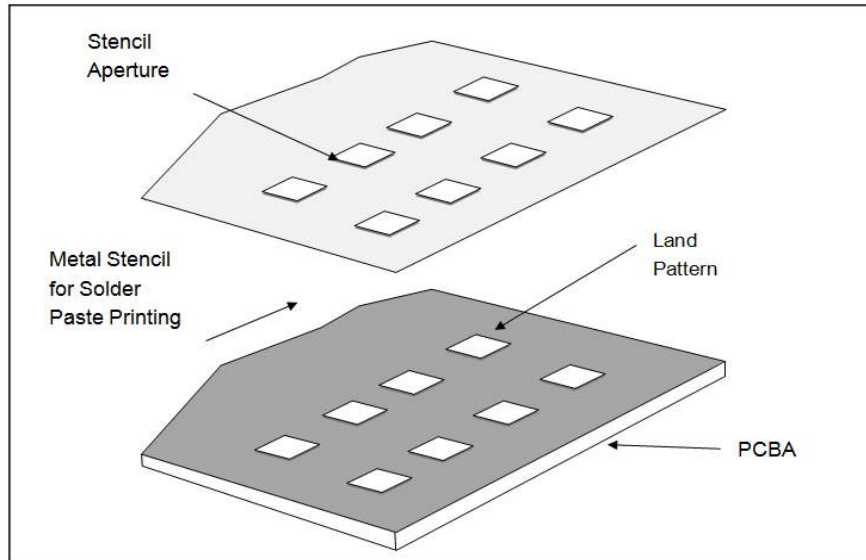

11.1. Recommended Metal Stencil Aperture

It is recommended that the metal stencil used for solder paste printing has a thickness (t) of 0.11mm (0.004 inches / 4 mils) or 0.127mm (0.005 inches / 5 mils).

The stencil aperture opening is recommended to be 0.3mm x 0.65mm which has the same dimension as the land pattern. This is to ensure adequate printed solder paste volume and yet no shorting.

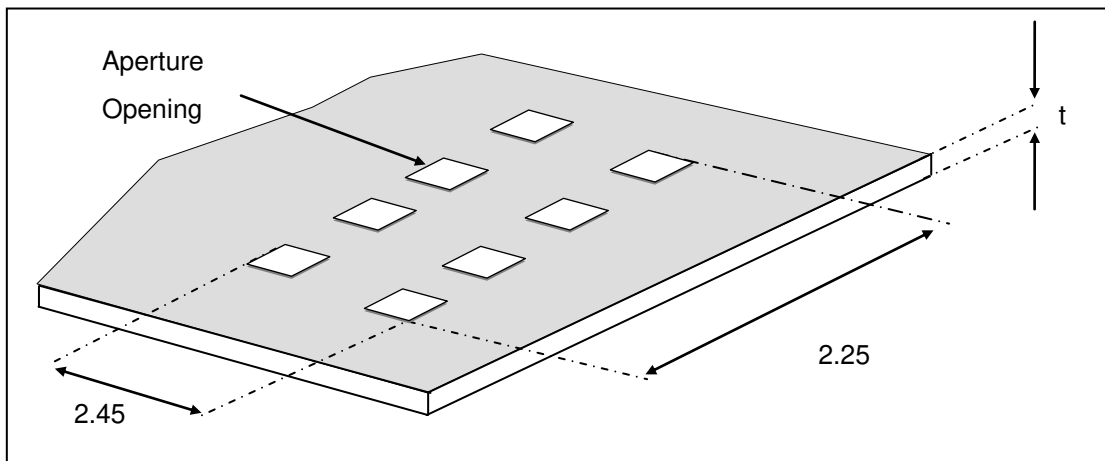

Note:

1. All dimensions are in millimeters

12. Package Dimension for Tape and Reel

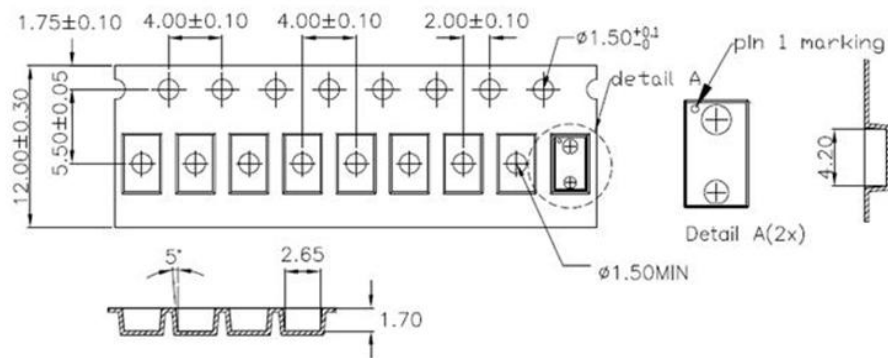

Notes:

1. 10 sprocket hole pitch cumulative tolerance ± 0.20 .
2. Material : Black Conductive Polystyrene Alloy.
3. All dimensions meet E1A-481-C requirements.
4. Thickness : 0.30 ± 0.05 mm.

12.1. Package Dimension of Reel

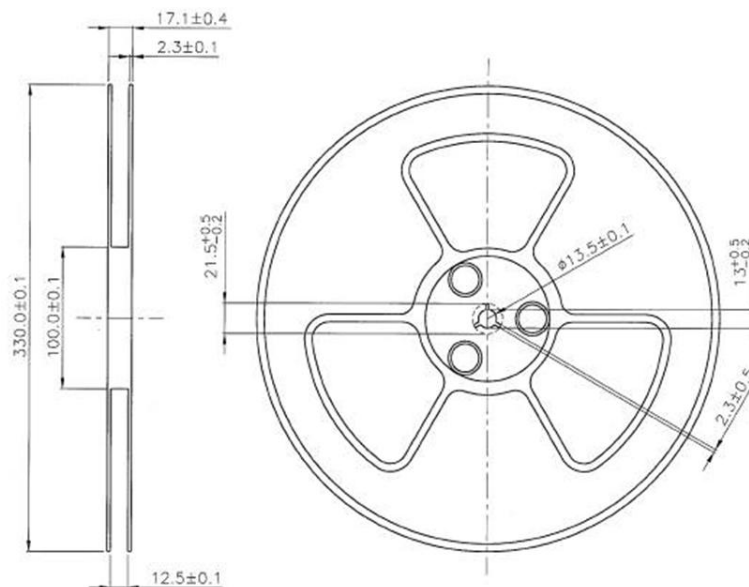

Notes:

1. All dimensions are in millimeters (inches)
2. Empty component pockets sealed with top cover tape
3. 13 inch reel - 8000 pieces per reel

**OPTICAL SENSOR
LTR-91400**

4. In accordance with ANSI/EIA 481-1-A-1994 specifications

Revision Table:

Version	Update	Page	Date
1.0	Datasheet as created	Total 43	13-Jul-15
1.1	Updated interrupt plot on page 32	32	14-Jan-16