

PRODUCT NUMBER
SEE TABLE

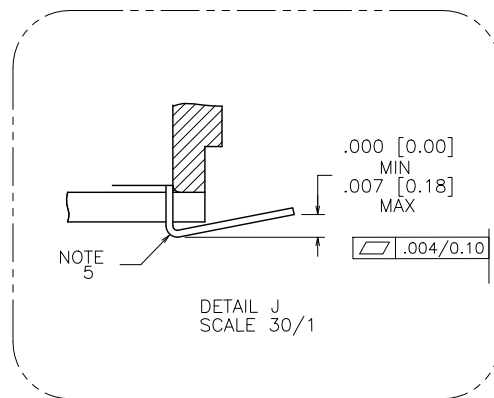

mat'l. code				surface		tolerance		projection		product family	
-				ISO 1302 ✓		ISO 406 ISO 1101				RIB CAGE	
ltr	ecn no	dr	date	tolerances unless otherwise specified						title	
K	V10994	DLW	3/09/01	angles	linear	xx ±.01/.3		INCH/MM		.050/1.27 VERTICAL CARD CONNECTOR	
L	V11674	CRG	7/16/01			xxx ±.005/.13				SURF. MT. W/LOC. AND POL. FEATURES	
M	M05-0123	ERE	6/10/05	σ±2'			xxxx ±.0020/.050		scale 4:1		
N	M06-0284	AEA	7/27/06	dr	M. CORNMAN	6/10/92				dwg no sheet 1 of 2 size	
P	M09-0058	MHT	4/04/09	engr	J. SHUEY	6/10/92				92074 A3	
R	N10-0174	YO	6/18/10	chr	C. GINGRICH	6/10/92				type Product Customer Drawing	
S	ELX-N-010208	YO	2/8/12	appd	J. SHUEY	6/10/92					
sheet	revision	S	S								
index	sheet	1	2								

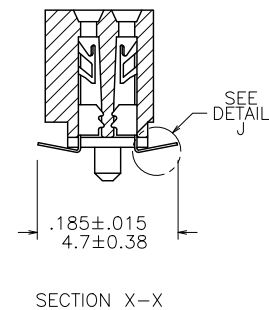
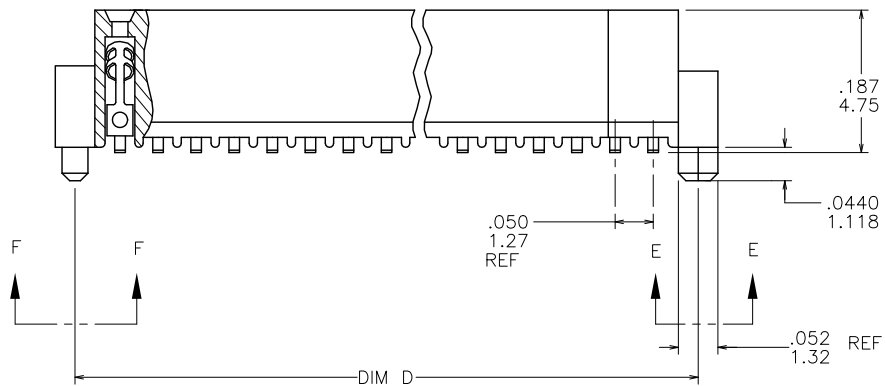
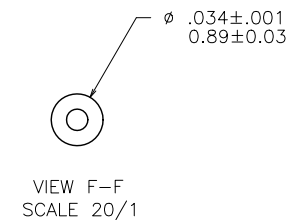
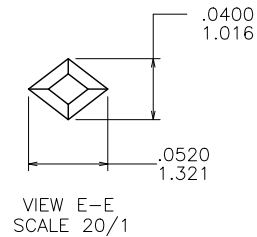
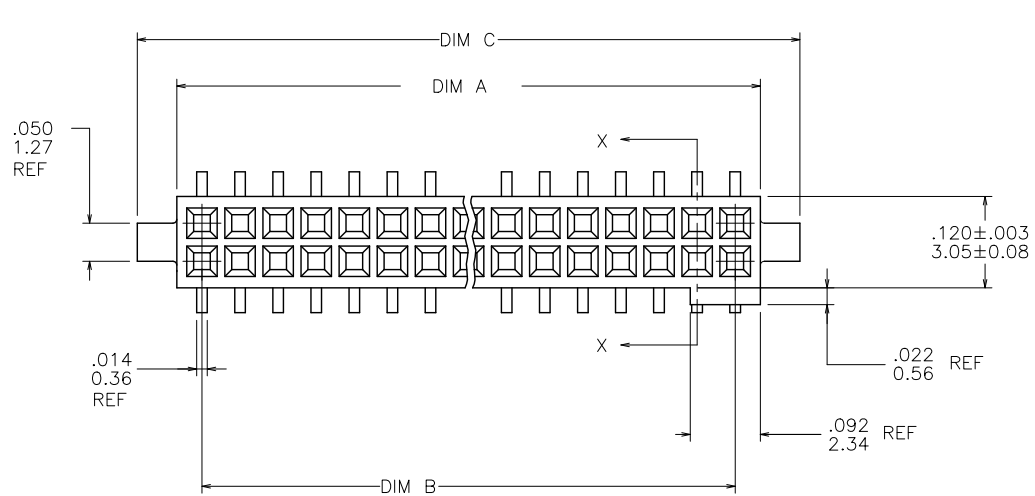