

NOTE:

MATERIAL

HOUSING: PBT UL94V-0, BLACK
 CONTACT: GOLD PLATED BRASS
 SHELL: SEE P/N KEY
 NUT: SEE P/N KEY
 O-RING 1: NBR, BLACK
 O-RING 2: EPDM, BLACK

ELECTRICAL

RATED CURRENT: 3A
 RATED VOLTAGE: 60V
 INSULATION RESISTANCE: 100 MΩhms MIN.
 CONTACT RESISTANCE: 10 mΩhms MAX.
 WATER PROOF: IP67

ENVIRONMENT

OPERATION TEMPERATURE: -40°C TO +85°C

MAX WIRE AWG: 24

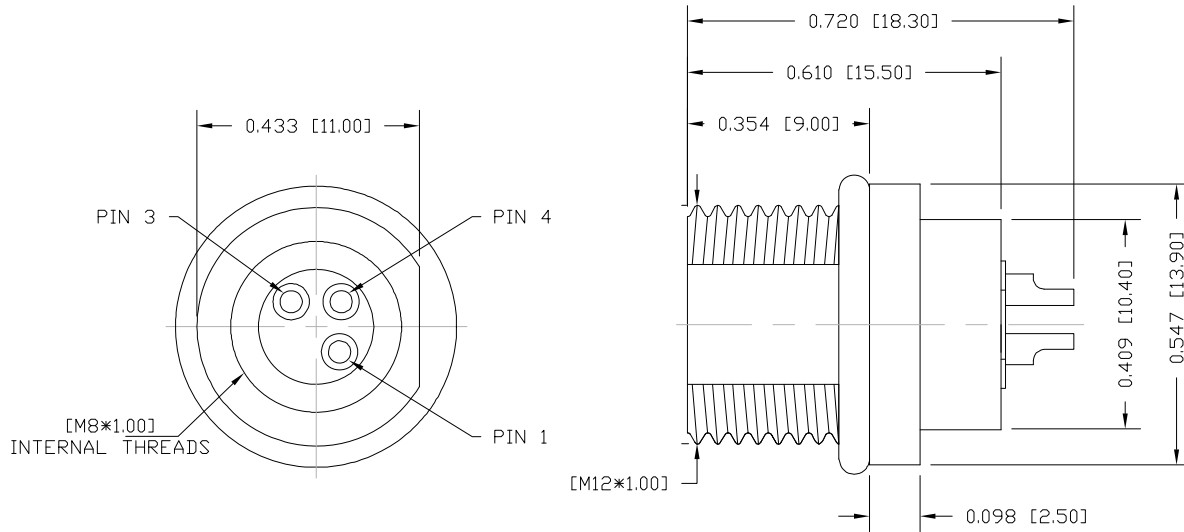

855-003-20YR00Y

3 = BRASS/NICKEL SHELL & NUT
 S = 316 STAINLESS STEEL SHELL & NUT

1 = GOLD FLASH
 4 = 10μ" GOLD

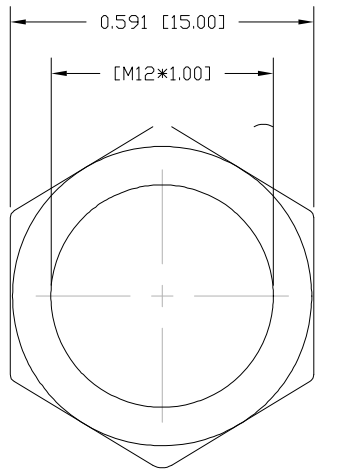

NUT

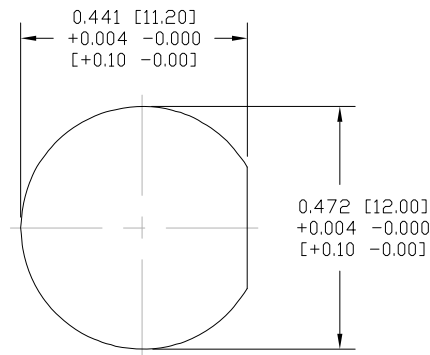

PANEL CUTOUT

RoHS COMPLIANT

UNITS = inch [mm]

DO NOT SCALE FROM DRAWING



THESE DRAWINGS AND SPECIFICATIONS ARE THE PROPERTY OF NorComp AND SHALL NOT BE REPRODUCED, COPIED OR USED AS THE BASIS FOR THE MANUFACTURE OR SALE OF APPARATUS WITHOUT WRITTEN PERMISSION.

DRAWN: M. SIGMON

DATE: 03/04/2016

NorComp

SCALE: NTS

SHEET 1 OF 1

REV 6

DWG NO.

855-003-203R00Y