

This document is the property of Amphenol Corporation and is delivered on the express condition that it is not to be disclosed, reproduced or used, in whole or in part, for manufacture or sale by anyone other than Amphenol Corporation without its prior consent, and that no right is granted to disclose or to use any information in this document.

The marking on this product doesn't contain environmental hazardous materials per Material Specification 55-00259 for Sony GP compliant or per directive 2002/95/EC for RoHS compliant.



ORIGINAL



REVISIONS				
SYM	ECN No.	DESCRIPTION	DATE	APPROVED
A		RELEASE TO PRODUCTION	12/11/2007	Hank Hsu
B	NE-08052	MODIFIED DIMENSION TABLE	01/30/2008	Hank Hsu
C	NE-12115	MODIFIED DRAWING	08/30/2012	Roger Tsai

G825 040 10X0 YEU	1 x 40 = 40	80.00	78.00
G825 039 10X0 YEU	1 x 39 = 39	78.00	76.00
G825 038 10X0 YEU	1 x 38 = 38	76.00	74.00
G825 037 10X0 YEU	1 x 37 = 37	74.00	72.00
G825 036 10X0 YEU	1 x 36 = 36	72.00	70.00
G825 035 10X0 YEU	1 x 35 = 35	70.00	68.00
G825 034 10X0 YEU	1 x 34 = 34	68.00	66.00
G825 033 10X0 YEU	1 x 33 = 33	66.00	64.00
G825 032 10X0 YEU	1 x 32 = 32	64.00	62.00
G825 031 10X0 YEU	1 x 31 = 31	62.00	60.00
G825 030 10X0 YEU	1 x 30 = 30	60.00	58.00
G825 029 10X0 YEU	1 x 29 = 29	58.00	56.00
G825 028 10X0 YEU	1 x 28 = 28	56.00	54.00
G825 027 10X0 YEU	1 x 27 = 27	54.00	52.00
G825 026 10X0 YEU	1 x 26 = 26	52.00	50.00
G825 025 10X0 YEU	1 x 25 = 25	50.00	48.00
G825 024 10X0 YEU	1 x 24 = 24	48.00	46.00
G825 023 10X0 YEU	1 x 23 = 23	46.00	44.00
G825 022 10X0 YEU	1 x 22 = 22	44.00	42.00
G825 021 10X0 YEU	1 x 21 = 21	42.00	40.00
G825 020 10X0 YEU	1 x 20 = 20	40.00	38.00
G825 019 10X0 YEU	1 x 19 = 19	38.00	36.00
G825 018 10X0 YEU	1 x 18 = 18	36.00	34.00
G825 017 10X0 YEU	1 x 17 = 17	34.00	32.00
G825 016 10X0 YEU	1 x 16 = 16	32.00	30.00
G825 015 10X0 YEU	1 x 15 = 15	30.00	28.00
G825 014 10X0 YEU	1 x 14 = 14	28.00	26.00
G825 013 10X0 YEU	1 x 13 = 13	26.00	24.00
G825 012 10X0 YEU	1 x 12 = 12	24.00	22.00
G825 011 10X0 YEU	1 x 11 = 11	22.00	20.00
G825 010 10X0 YEU	1 x 10 = 10	20.00	18.00
G825 009 10X0 YEU	1 x 9 = 9	18.00	16.00
G825 008 10X0 YEU	1 x 8 = 8	16.00	14.00
G825 007 10X0 YEU	1 x 7 = 7	14.00	12.00
G825 006 10X0 YEU	1 x 6 = 6	12.00	10.00
G825 005 10X0 YEU	1 x 5 = 5	10.00	8.00
G825 004 10X0 YEU	1 x 4 = 4	8.00	6.00
G825 003 10X0 YEU	1 x 3 = 3	6.00	4.00
G825 002 10X0 YEU	1 x 2 = 2	4.00	2.00
PART NUMBER	NO. OF POS.	A	B

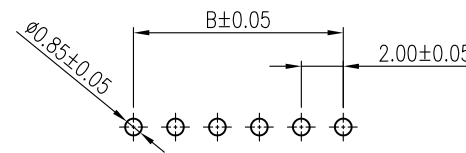
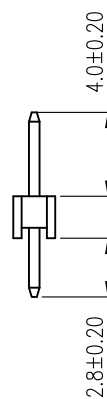
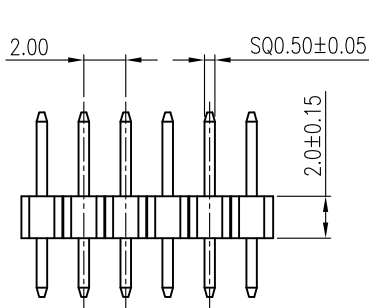
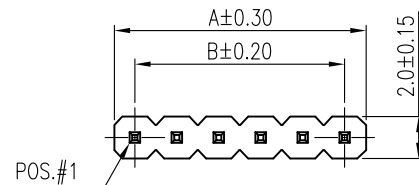

RECOMMENDED PCB LAYOUT
ALL TOLERANCE ±0.05

NOTES:

- INSULATOR: LCP, UL 94V-0, COLOR- BLACK
- PIN CONTACT: COPPER ALLOY, SELECTIVE GOLD OR TIN PLATED
 "X"- CONTACT FINISH CODE IN P/N
 "0"- FULL GOLD FLASH
 "1"- FLASH GOLD
 "2"- 15μ" GOLD
 "3"- 30μ" GOLD
 "4"- TIN
- THIS PRODUCT DOESN'T CONTAIN ENVIRONMENTAL HAZARDOUS MATERIALS PER DIRECTIVE 2002/95/EC FOR RoHS.
- PACKING IS PER AMTA PACKING SPECIFICATION PKS-0001
- CURRENT RATING: 1.5 AMPS/CONTACT MAX.

TOLERANCE		APPROVALS		DATE	TITLE		Amphenol®			
X.		DRAWN		Aqua Chou	08/30/2012	PCB HEADER		Amphenol Corporation Amphenol Taiwan Corporation		
X.X	±0.30	CHECKED		Roger Tsai	08/30/2012	2.0MM PITCH, SINGLE ROWS				
X.XX	±0.20	APPROVED		Roger Tsai	08/30/2012	STRAIGHT PCB MOUNT		PART No. G825XXX10X0YEU		
X.XXX	±0.10	DWG TYPE		CUST DWG	PROJECT CODE	HEAD	UNIT	mm	SIZE	A3
ANGULAR	±1°	UNLESS OTHERWISE SPECIFIED					SCALE	NA	SHEET	1 OF 2
							DWG No. G825XXX10X0YEU		REV. C	

This document is the property of Amphenol Corporation and is delivered on the express condition that is not to be disclosed, reproduced or used, in whole or in part, for manufacture or sale by anyone other than Amphenol Corporation without its prior consent, and that no right is granted to disclose or to use any information in this document.

The marking on this product doesn't contain environmental hazardous materials per Material Specification SS-00259 for Sony GP compliant or per directive 2002/95/EC for RoHS compliant.

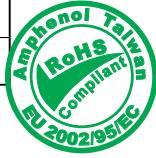

ORIGINAL



REVISIONS				
SYM	ECN No.	DESCRIPTION	DATE	APPROVED
A		RELEASE TO PRODUCTION	12/11/2007	Hank Hsu
B	NE-08052	MODIFIED DIMENSION TABLE	01/30/2008	Hank Hsu
C	NE-12115	MODIFIED DRAWING	08/30/2012	Roger Tsai

G825XXX10X0YEU

DESICCANT

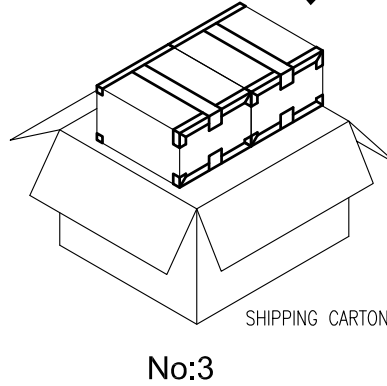
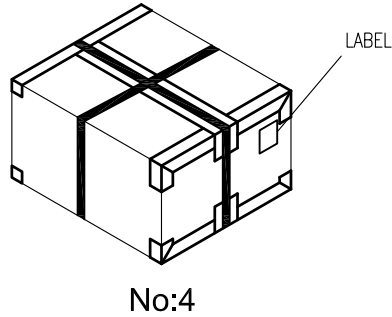
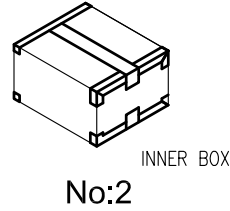

NOTES:

1. PE BAG SIZE : 195 X 265 mm
2. INNER BOX SIZE : 215 X 175 X 150 mm
3. SHIPPING CARTON SIZE : 370 X 230 X 175 mm

G825 006 1000YEU	06	1000	20	2	40000	6.8	7.6
G825 004 1000YEU	04	1000	25	2	50000	5.6	6.3
G825 003 1000YEU	03	1000	30	2	60000	5.1	5.9
G825 002 1000YEU	02	1000	30	2	60000	3.4	4.1
P/N	POS.	PCS/BAG	BAG/INNER BOX	INNER BOX/SHIPPING BOX	QUANTITY (PCS)	N.W. KG	G.W. KG

TOLERANCE	APPROVALS	DATE	TITLE		Amphenol®		
X. ±0.30	DRAWN Aqua Chou	08/30/2012	PCB HEADER		Amphenol Corporation		
X.X ±0.20	CHECKED Roger Tsai	08/30/2012	2.0MM PITCH, SINGLE ROWS		Amphenol Taiwan Corporation		
X.XXX ±0.10	APPROVED Roger Tsai	08/30/2012	STRAIGHT PCB MOUNT		UNIT mm	SIZE A3	PART No. G825XXX10X0YEU
ANGULAR ±1°	DWG TYPE CUST DWG	PROJECT CODE HEAD		SCALE NA	SHEET 2 OF 2	DWG No. G825XXX10X0YEU	REV. C
UNLESS OTHERWISE SPECIFIED							