

## Description

The LM358 series consists of two independent, high gain, internally frequency compensated operational amplifiers which were designed specifically to operate from a single power supply over a wide range of voltages. Operation from split power supplies is also possible and the low power supply current drain is independent of the magnitude of the power supply voltage.

Application areas include transducer amplifiers, dc gain blocks and all the conventional op amp circuits which now can be more easily implemented in single power supply systems. For example, the LM358 series can be directly operated from the standard +5V power supply voltage which is used in digital systems and will easily provide the required interface electronics without requiring an additional  $\pm 15V$  power supply.

## Features

- Internally frequency compensated for unity gain
- Large dc voltage gain: 100 dB
- Very low supply current drain (500 $\mu A$ ); essentially independent of supply voltage
- Wide bandwidth (unity gain): 1MHz (temperature compensated)
- Input common-mode voltage range includes ground
- Differential input voltage range equal to the power supply voltage
- Low input offset voltage: 2mV
- Wide power supply range:
  - Single supply: 3V to 32V
  - Dual supplies:  $\pm 1.5V$  to  $\pm 16V$
- Large output voltage swing: 0V to  $V^+ - 1.5V$
- SOP-8L packaging
- "Green" Molding Compound (No Br, Sb)
- Lead Free Finish/ RoHS Compliant (Note 1)

Notes: 1. EU Directive 2002/95/EC (RoHS). All applicable RoHS exemptions applied. Please visit our website at [http://www.diodes.com/products/lead\\_free.html](http://www.diodes.com/products/lead_free.html).

## Pin Assignments

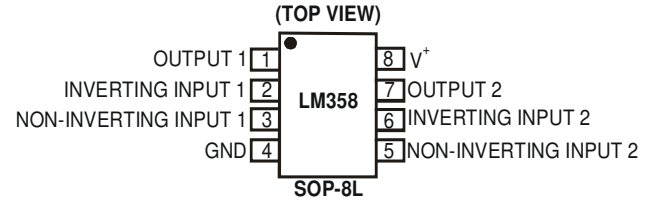

## Applications

- Eliminates the need for dual supplies
- Compatible with all forms of logic
- Two internally compensated op amps
- Low power drain ideal for battery operation
- Allows direct sensing near GND
- $V_{OUT}$  can swing to GND

## Unique Characteristics

- In the linear mode the input common-mode voltage range includes ground and the output voltage can also swing to ground, whilst operating from only a single power supply voltage.
- The unity gain crossing frequency is temperature compensated.
- The input bias current is temperature compensated.

**Typical Single-Supply Circuit ( $V^+ = 5.0V_{DC}$ )**

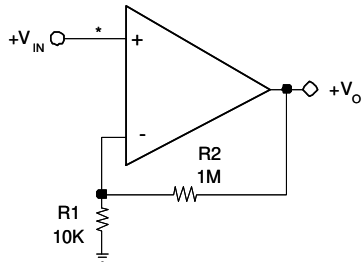

\*R not needed due to temperature independent  $I_{IN}$

**Non-Inverting DC Gain (0V Output)**

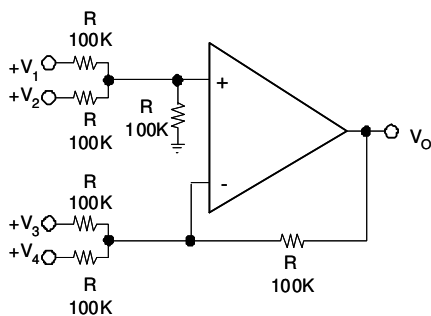
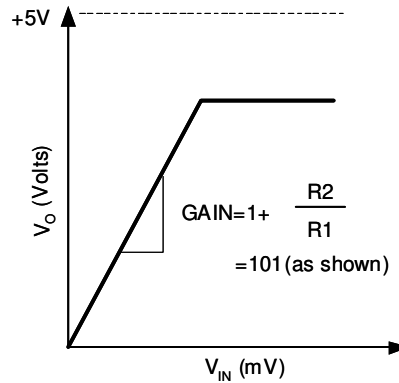

Where:  $V_O = V_1 + V_2 - V_3 - V_4$   
( $V_1 + V_2 > V_3 + V_4$ ) to keep  $V_O > 0 V_{DC}$

**DC Summing Amplifier**  
( $V_{IN'S} \geq 0 V_{DC}$  and  $V_O \geq 0 V_{DC}$ )

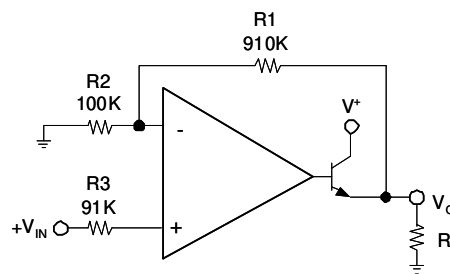

$V_O = 0 V_{DC}$  for  $V_{IN} = 0 V_{DC}$   
 $A_V = 10$

**Power Amplifier**

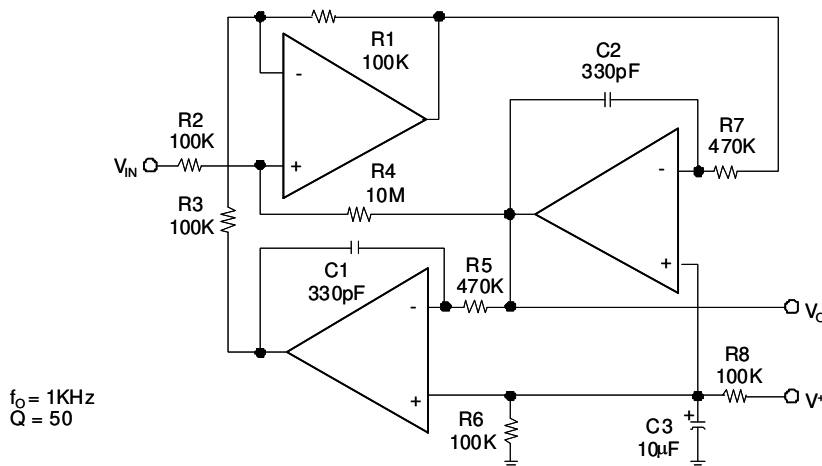

$f_o = 1KHz$   
 $Q = 50$

**"BI-QUAD" RC Active Bandpass Filter**

NEW PRODUCT

**Typical Single-Supply Circuit (Continued) ( $V^+ = 5.0V_{DC}$ )**

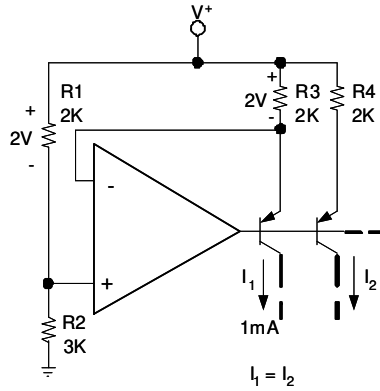

**Fixed Current Sources**

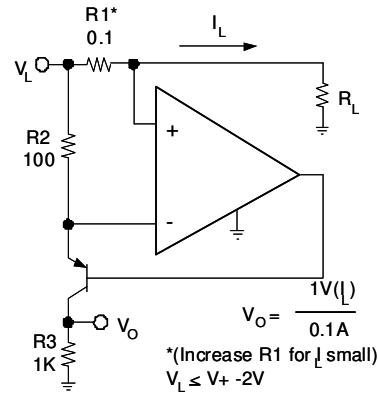

**Current Monitor**

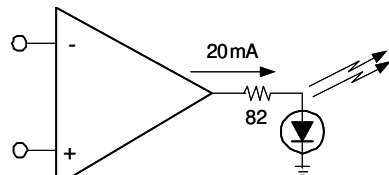

**LED Driver**

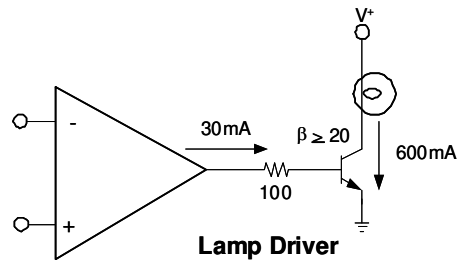

**Lamp Driver**

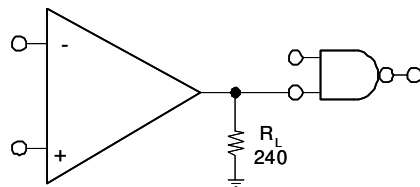

**Driving TTL**

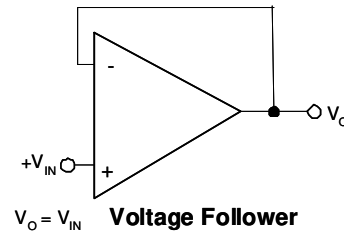

**Voltage Follower**

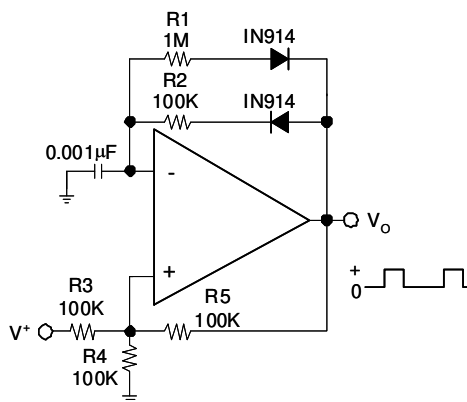

**Pulse Generator**

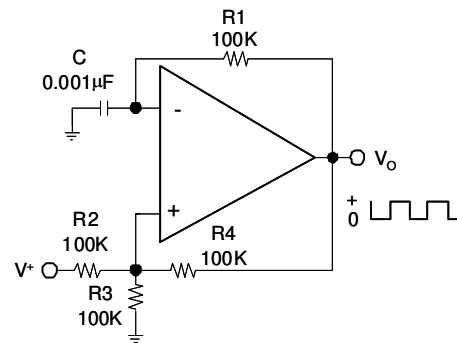

**Square wave Oscillator**

NEW PRODUCT

**Typical Single-Supply Circuit (Continued) ( $V^+ = 5.0V_{DC}$ )**

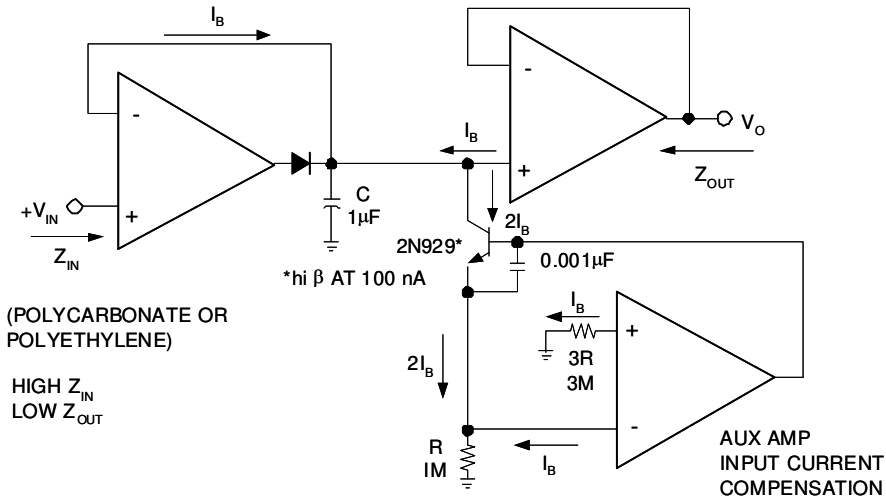

**Low Drift Peak Detector**

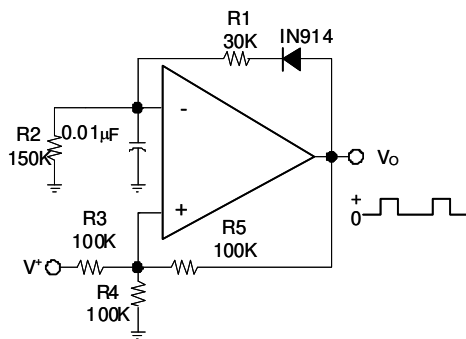

**Pulse Generator**

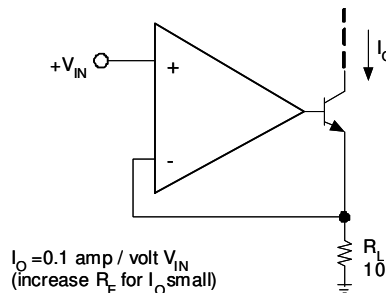

$I_O = 0.1 \text{ amp / volt } V_{IN}$   
(increase  $R_E$  for  $I_{O,small}$ )

**High Compliance Current Sink**

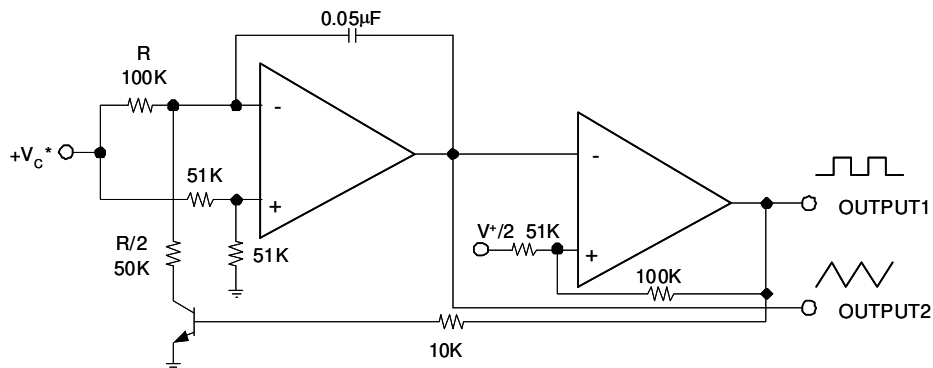

\*WIDE CONTROL VOLTAGE RANGE:  $0 V_{DC} \leq V_C \leq 2 (V^+ - 1.5V_{DC})$

**Voltage Controlled Oscillator (VCO)**

NEW PRODUCT

**Typical Single-Supply Circuit (Continued) ( $V^+ = 5.0V_{DC}$ )**

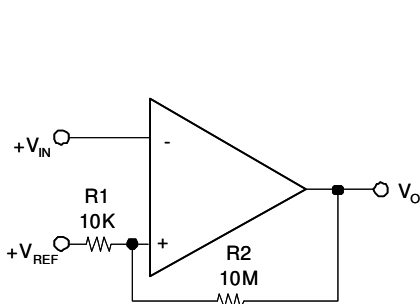

**Comparator with Hysteresis**

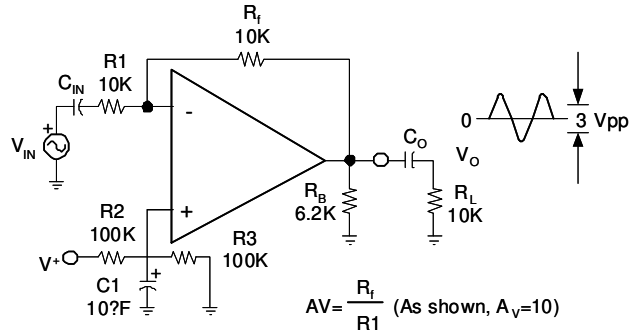

**AC Coupled Inverting Amplifier**

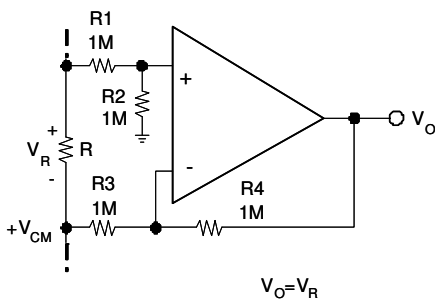

**Ground Referencing a Differential Input Signal**

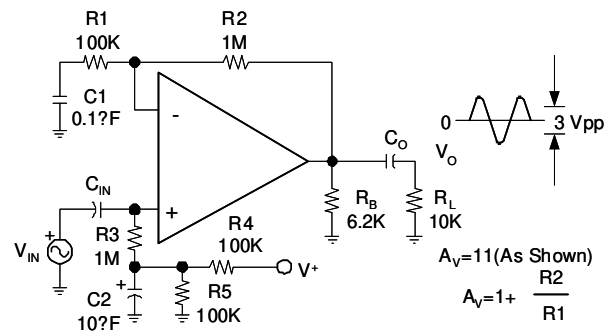

**AC Coupled Non-Inverting Amplifier**

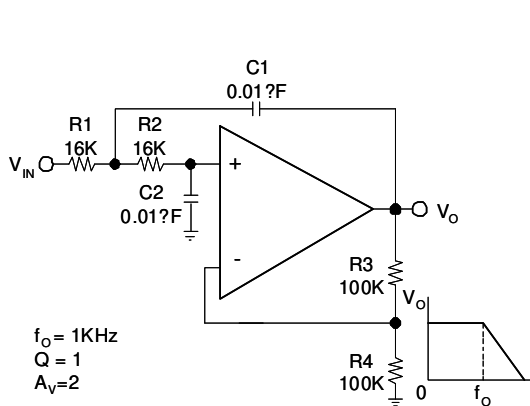

**DC Coupled Low-Pass RC Active Filter**

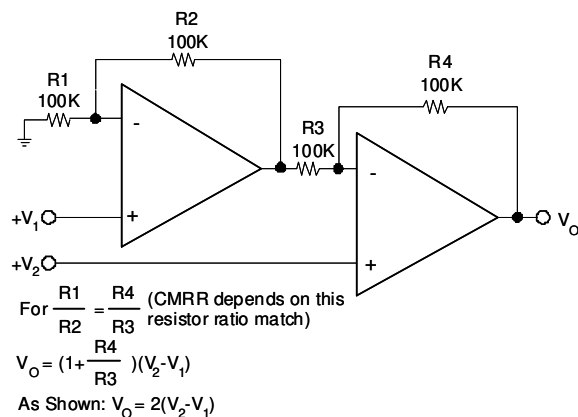

**High Input Z, DC Differential Amplifier**

**Typical Single-Supply Circuit (Continued) ( $V^+ = 5.0V_{DC}$ )**

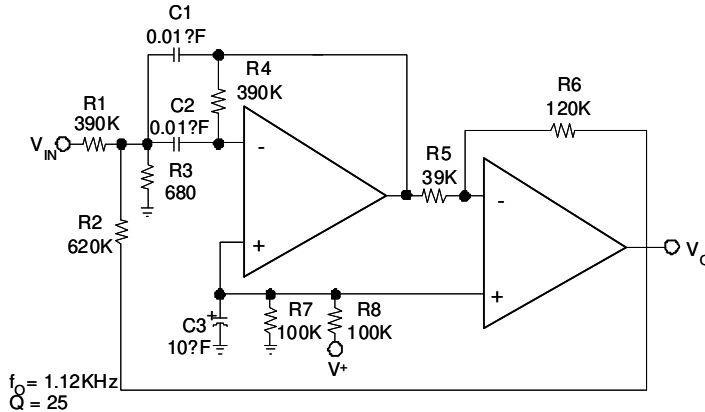

**Bandpass Active Filter**

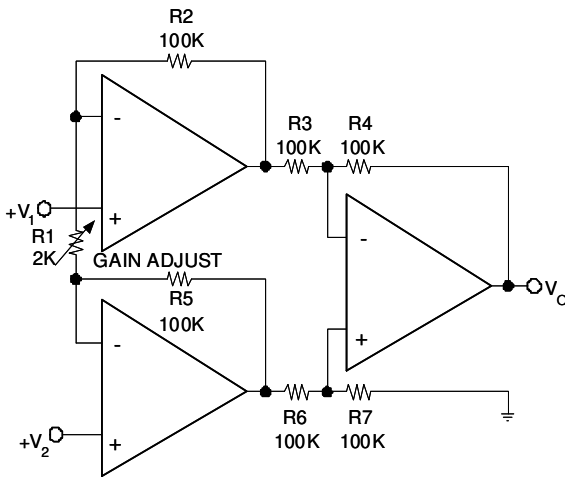

If  $R_1 = R_5$  &  $R_3 = R_4 = R_6 = R_7$  (CMRR depends on match)

$$V_o = \left(1 + \frac{2R_2}{R_1}\right)(V_2 - V_1)$$

As Shown:  $V_o = 101(V_2 - V_1)$

**High Input Z Adjustable-Gain  
DC Instrumentation Amplifier**

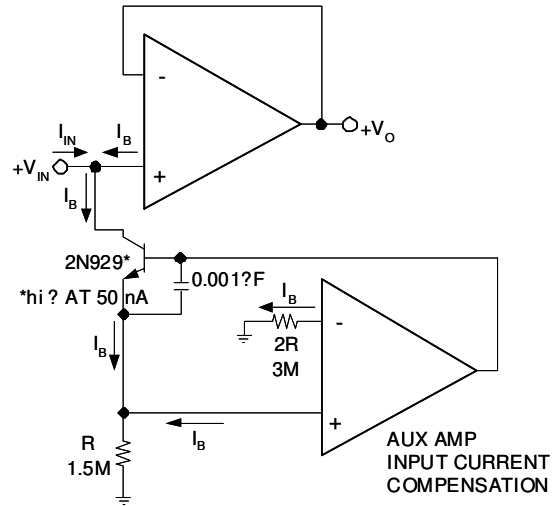

**Using Symmetrical Amplifiers to Reduce  
Input Current (General Concept)**

**Functional Block Diagram**

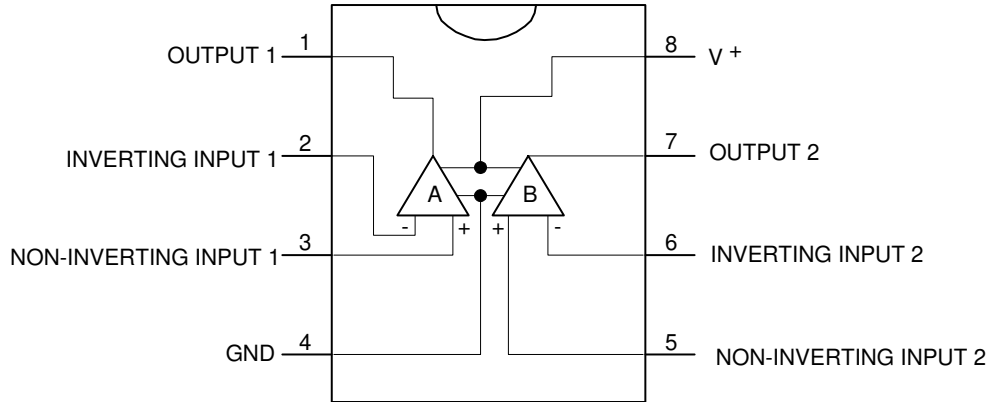

**Pin Descriptions**

Pin Name	Pin #	Description
OUTPUT 1	1	Channel 1 Output
INVERTING INPUT 1	2	Channel 1 Inverting Input
NON-INVERTING INPUT 1	3	Channel 1 Non-inverting Input
GND	4	Ground
NON-INVERTING INPUT 2	5	Channel 2 Non-inverting Input
INVERTING INPUT 2	6	Channel 2 Inverting Input
OUTPUT 2	7	Channel 2 Output
V+	8	Chip Supply Voltage

NEW PRODUCT

### Absolute Maximum Ratings

Symbol	Parameter	Rating	Unit
$V_{CC}$	Supply voltage	32	V
	Differential Input Voltage	32	V
$V_{IN}$	Input Voltage	-0.3 to +32	V
$P_D$	Power Dissipation (Note 2)	600	mW
	Output Short-Circuit to GND (One Amplifier) (Note 3)	Continuous	
	Input Current ( $V_{IN} < -0.3V$ ) (Note 4)		
$T_{OP}$	Operating Temperature Range	0 to +70	°C
$T_{ST}$	Storage Temperature Range	-65 to +150	°C

- Notes:
- For operating at high temperatures, the LM358 must be derated based on a +125°C maximum junction temperature and a thermal resistance of 189°C/W, which applies for the device soldered in a printed circuit board, operating in a still air ambient. The dissipation is the total of both amplifiers; use external resistors, where possible, to allow the amplifier to saturate or to reduce the power which is dissipated in the integrated circuit.
  - Short circuits from the output to  $V^+$  can cause excessive heating and eventual destruction. When considering short circuits to ground, the maximum output current is approximately 40mA independent of the magnitude of  $V^+$ . At values of supply voltage in excess of +15V, continuous short-circuits can exceed the power dissipation ratings and cause eventual destruction. Destructive dissipation can result from simultaneous shorts on all amplifiers.
  - This input current will only exist when the voltage at any of the input leads is driven negative. It is due to the collector-base junction of the input PNP transistors becoming forward biased and thereby acting as input diode clamps. In addition to this diode action, there is also lateral NPN parasitic transistor action on the IC chip. This transistor action can cause the output voltages of the op amps to go to the  $V^+$  voltage level (or to ground for a large overdrive) for the time duration that an input is driven negative. This is not destructive and normal output states will re-establish when the input voltage, which was negative, again returns to a value greater than -0.3V (at 25°C).



### Electrical Characteristics ( $T_A = 25^\circ\text{C}$ , $V^+ = +5.0\text{V}$ , unless otherwise stated) (Note 5)

Symbol	Parameter	Conditions	Min	Typ.	Max	Unit	
$V_{IO}$	Input Offset Voltage	$T_A = 25^\circ\text{C}$ , (Note 6)	-	2	7	mV	
$I_B$	Input Bias Current	$I_{IN(+)}$ or $I_{IN(-)}$ , $T_A = 25^\circ\text{C}$ , $V_{CM} = 0\text{V}$ , (Note 7)	-	45	250	nA	
$I_{IO}$	Input Offset Current	$I_{IN(+)} - I_{IN(-)}$ , $V_{CM} = 0\text{V}$ , $T_A = 25^\circ\text{C}$	-	5	50	nA	
$V_{ICM}$	Input Common-Mode Voltage Range	$V^+ = 30\text{V}$ , (Note 8) $T_A = 25^\circ\text{C}$	0	-	$V^+ - 1.5$	V	
$I_S$	Supply Current Over Full Temperature Range	$R_L = \infty$ on All	-	1	2	mA	
		Op Amps	-	0.5	1.2		
$A_V$	Large Signal Voltage Gain	$V^+ = 15\text{V}$ , $T_A = 25^\circ\text{C}$ , $R_L > 2\text{k}\Omega$ , (For $V_O = 1\text{V}$ to $11\text{V}$ )	25	100	-	V/mV	
CMRR	Common-Mode Rejection Ratio	$T_A = 25^\circ\text{C}$ , $V_{CM} = 0\text{V}$ to $V^+ - 1.5\text{V}$	65	85	-	dB	
PSRR	Power Supply Rejection Ratio	$V^+ = 5\text{V}$ to $30\text{V}$ , $T_A = 25^\circ\text{C}$	65	100	-	dB	
	Amplifier-to-Amplifier Coupling	$f = 1\text{KHz}$ to $20\text{KHz}$ , $T_A = 25^\circ\text{C}$ (Input Referred) (Note 9)	-	-120	-	dB	
$I_{SINK}$	Output Current	Sink	$V_{IN(-)} = 1\text{V}$ , $V_{IN(+)} = 0\text{V}$ , $V^+ = 15\text{V}$ , $V_O = 2\text{V}$ , $T_A = 25^\circ\text{C}$	10	20	-	mA
		Source	$V_{IN(+)} = 1\text{V}$ , $V_{IN(-)} = 0\text{V}$ , $V^+ = 15\text{V}$ , $V_O = 200\text{mV}$ , $T_A = 25^\circ\text{C}$	20	70	-	$\mu\text{A}$
$I_{SOURCE}$		Source	$V_{IN(+)} = 1\text{V}$ , $V_{IN(-)} = 0\text{V}$ , $V^+ = 15\text{V}$ , $V_O = 2\text{V}$ , $T_A = 25^\circ\text{C}$	20	40	-	mA
$I_{SC}$	Short Circuit to Ground	$T_A = 25^\circ\text{C}$ , (Note 10) $V^+ = 15\text{V}$	-	40	60	mA	
$V_{OH}$	Output Voltage Swing	( $V^+ = 30\text{V}$ )	$R_L = 2\text{k}\Omega$ , $T_A = 25^\circ\text{C}$	26	-	-	V
			$R_L = 10\text{k}\Omega$ , $T_A = 25^\circ\text{C}$	27	28	-	V
$V_{OL}$		( $V^+ = 5\text{V}$ )	$R_L = 10\text{k}\Omega$ , $T_A = 25^\circ\text{C}$	-	5	20	mV

- Notes:
- The LM358 temperature specifications are limited to  $0^\circ\text{C} \leq T_A \leq +70^\circ\text{C}$ .
  - $V_O \cong 1.4\text{V}$ ,  $R_S = 0\Omega$  with  $V^+$  from  $5\text{V}$  to  $30\text{V}$ ; and over the full input common-mode range ( $0\text{V}$  to  $V^+ - 1.5\text{V}$ ) at  $25^\circ\text{C}$ .
  - The direction of the input current is out of the IC due to the PNP input stage. This current is essentially constant, independent of the state of the output so no loading change exists on the input lines.
  - The input common-mode voltage of either input signal voltage should not be allowed to go negative by more than  $0.3\text{V}$  (at  $25^\circ\text{C}$ ). The upper end of the common-mode voltage range is  $V^+ - 1.5\text{V}$  (at  $25^\circ\text{C}$ ), but either or both inputs can go to  $+32\text{V}$  without damage, independent of the magnitude of  $V^+$ .
  - Due to proximity of external components, insure that coupling is not originating via stray capacitance between these external parts. This typically can be detected as this type of capacitance increases at higher frequencies.
  - Short circuits from the output to  $V^+$  can cause excessive heating and eventual destruction. When considering short circuits to ground, the output maximum current is approximately  $40\text{mA}$  independent of the magnitude of  $V^+$ . At values of supply voltage in excess of  $+15\text{V}$ , continuous short-circuits can exceed the power dissipation ratings and cause eventual destruction. Destructive dissipation can result from simultaneous shorts on all amplifiers.

**Typical Performance Characteristics**

**Input Voltage Range**

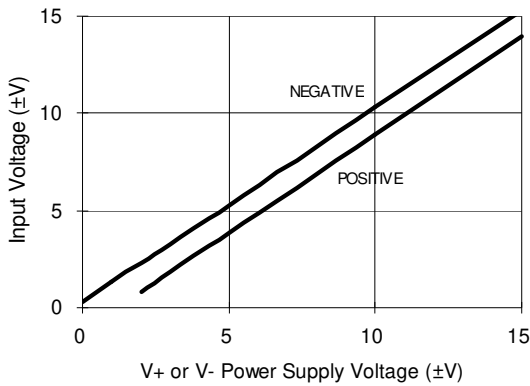

**Input Current vs Temperature**

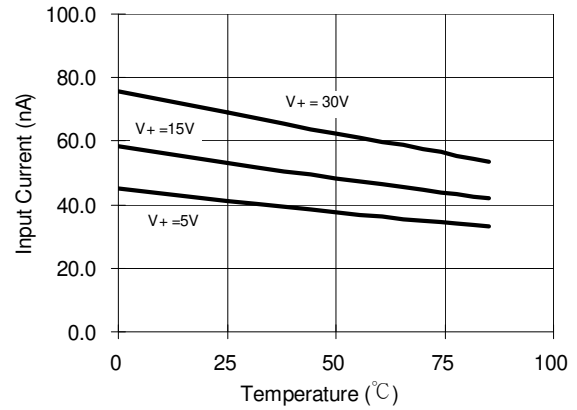

**Supply Current**

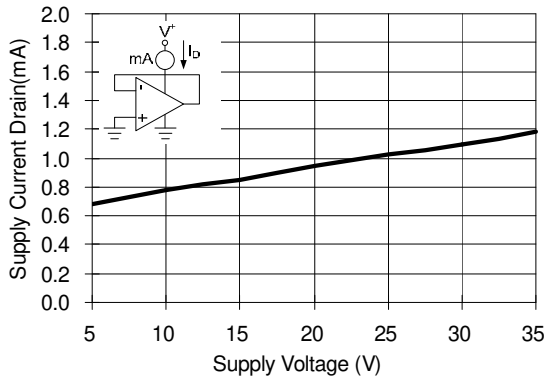

**Voltage Gain**

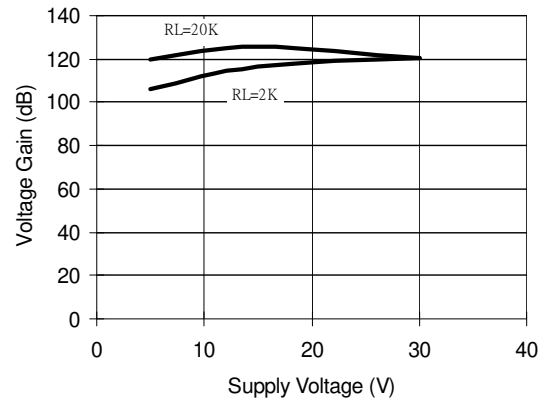

**Open Loop Frequency Response**

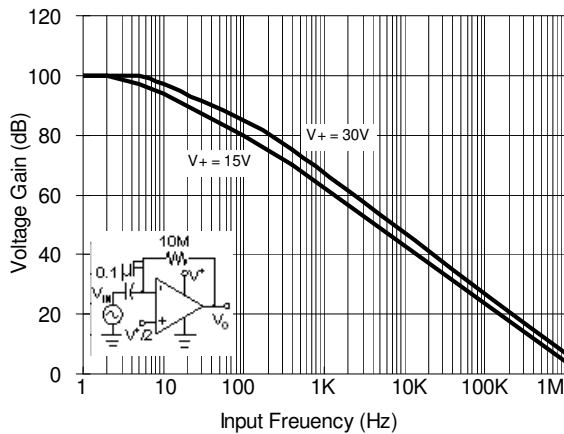

**Common-Mode Rejection Ratio**

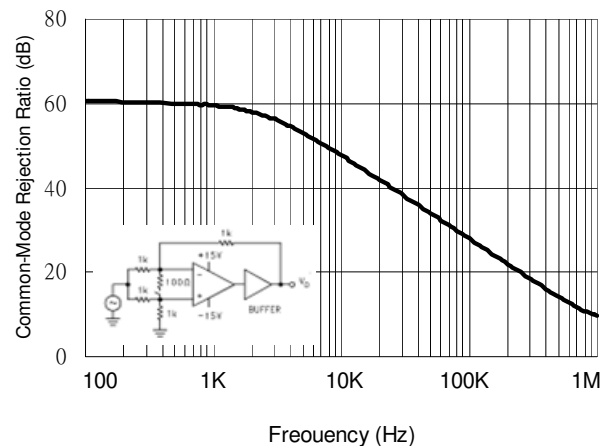

**Typical Performance Characteristics (Continued)**

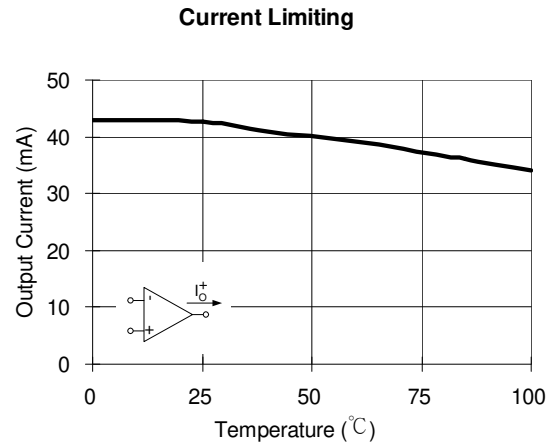
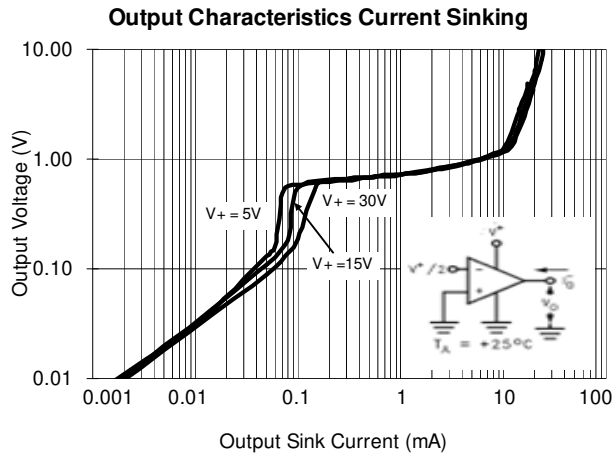
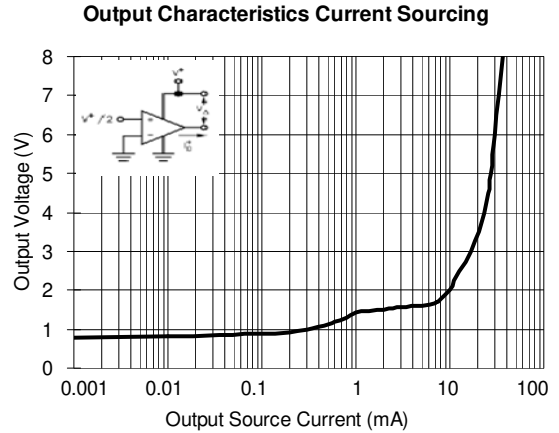
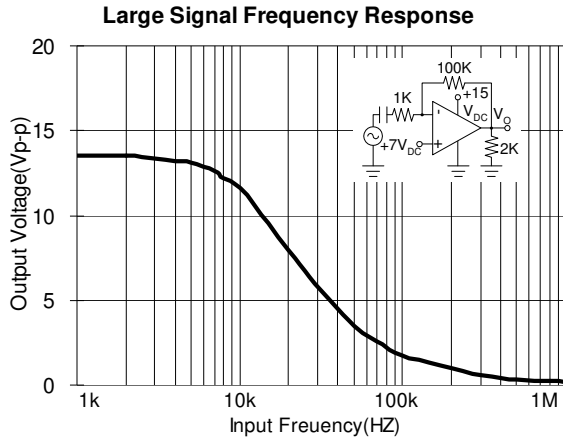

**Voltage Follower Pulse Response**

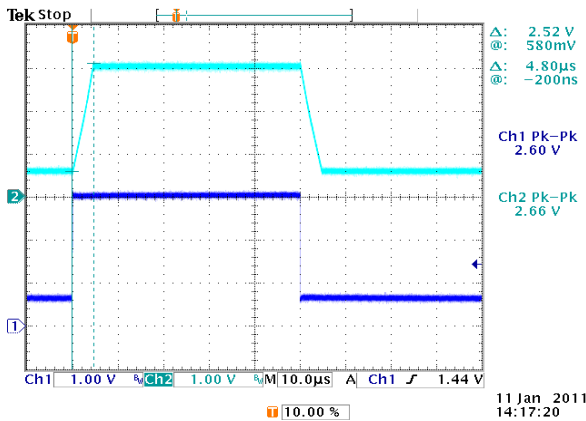

**Voltage Follower Pulse Response (Small Signal)**

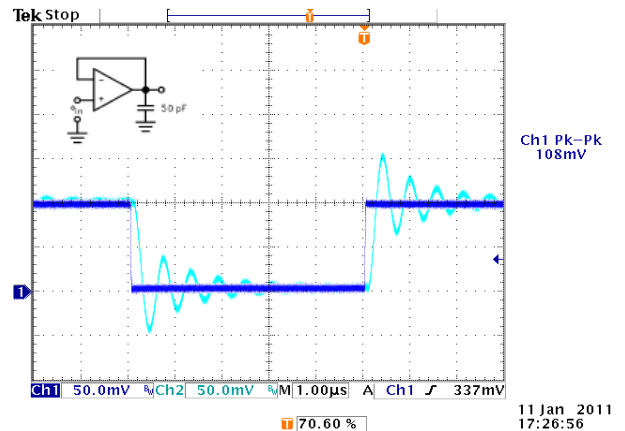

## Application Information

The LM358 series are op amps operate with only a single power supply voltage, have true-differential inputs, and remain in the linear mode with an input common-mode voltage of 0  $V_{DC}$ . These amplifiers operate over a wide range of power supply voltage with little change in performance characteristics. At 25°C amplifier operation is possible down to a minimum supply voltage of 2.3  $V_{DC}$ .

Precautions should be taken to insure that the power supply for the integrated circuit never becomes reversed in polarity or that the unit is not inadvertently installed backwards in a test socket as an unlimited current surge through the resulting forward diode within the IC could cause fusing of the internal conductors and result in a destroyed unit.

Large differential input voltages can be easily accommodated and, as input differential voltage protection diodes are not needed, no large input currents result. The differential input voltage may be larger than  $V^+$  without damaging the device. Protection should be provided to prevent the input voltages from going negative more than  $-0.3 V_{DC}$  (at 25°C). An input clamp diode with a resistor to the IC input terminal can be used.

To reduce the power supply current drain, the amplifiers have a class A output stage for small signal levels which converts to class B in a large signal mode. This allows the amplifiers to both source and sink large output currents. Therefore both NPN and PNP external current boost transistors can be used to extend the power capability of the basic amplifiers. The output voltage needs to raise approximately 1 diode drop above ground to bias the on-chip vertical PNP transistor for output current sinking applications.

For AC applications, where the load is capacitively coupled to the output of the amplifier, a resistor should be used, from the output of the amplifier to ground to increase the class A bias current and prevent crossover

distortion. Where the load is directly coupled, as in DC applications, there is no crossover distortion.

Capacitive loads which are applied directly to the output of the amplifier reduce the loop stability margin. Values of 50pF can be accommodated using the worst-case non-inverting unity gain connection. Large closed loop gains or resistive isolation should be used if a larger load capacitance must be driven by the amplifier.

The bias network of the LM358 establishes a drain current which is independent of the magnitude of the power supply voltage over the range of 3  $V_{DC}$  to 30  $V_{DC}$ .

Output short circuits either to ground or to the positive power supply should be of short time duration. Units can be destroyed, not as a result of the short circuit current causing metal fusing, but rather due to the large increase in IC chip dissipation which will cause eventual failure due to excessive junction temperatures. Putting direct short-circuits on more than one amplifier at a time will increase the total IC power dissipation to destructive levels, if not properly protected with external dissipation limiting resistors in series with the output leads of the amplifiers. The larger value of output source current which is available at 25°C provides a larger output current capability at elevated temperatures (see typical performance characteristics) than a standard IC op amp.

The circuits presented in the section on typical applications emphasize operation on only a single power supply voltage. If complementary power supplies are available, all of the standard op amp circuits can be used. In general, introducing a pseudo-ground (a bias voltage reference of  $V^+/2$ ) will allow operation above and below this value in single power supply systems. Many application circuits are shown which take advantage of the wide input common-mode voltage range which includes ground. In most cases, input biasing is not required and input voltages which range to ground can easily be accommodated.

**Ordering Information**

Device	Package Code	Packaging (Note 10)	Tube		13" Tape and Reel	
			Quantity	Part Number Suffix	Quantity	Part Number Suffix
LM358S-13	S	SOP-8L	NA	NA	2500/Tape & Reel	-13



Notes: 10. Pad layout as shown on Diodes Inc. suggested pad layout document AP02001, which can be found on our website at <http://www.diodes.com/datasheets/ap02001.pdf>.

**Marking Information**

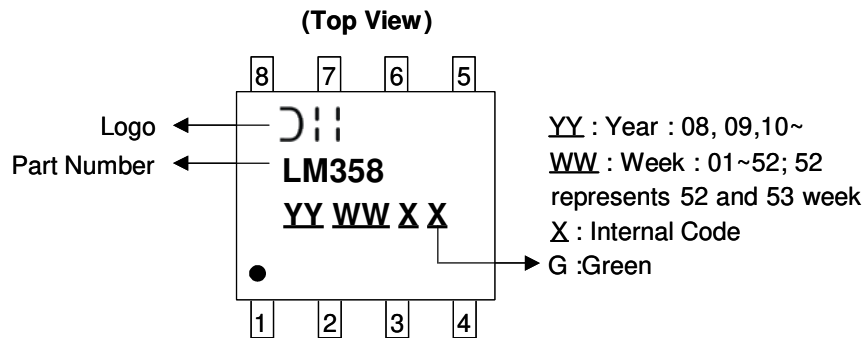

**Package Outline Dimensions (All Dimensions in mm)**

Package type: SOP-8L

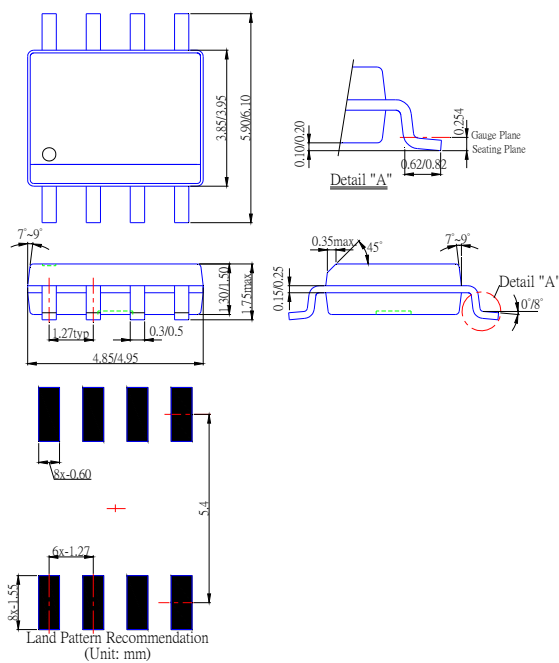

NEW PRODUCT

**IMPORTANT NOTICE**

DIODES INCORPORATED MAKES NO WARRANTY OF ANY KIND, EXPRESS OR IMPLIED, WITH REGARDS TO THIS DOCUMENT, INCLUDING, BUT NOT LIMITED TO, THE IMPLIED WARRANTIES OF MERCHANTABILITY AND FITNESS FOR A PARTICULAR PURPOSE (AND THEIR EQUIVALENTS UNDER THE LAWS OF ANY JURISDICTION).

Diodes Incorporated and its subsidiaries reserve the right to make modifications, enhancements, improvements, corrections or other changes without further notice to this document and any product described herein. Diodes Incorporated does not assume any liability arising out of the application or use of this document or any product described herein; neither does Diodes Incorporated convey any license under its patent or trademark rights, nor the rights of others. Any Customer or user of this document or products described herein in such applications shall assume all risks of such use and will agree to hold Diodes Incorporated and all the companies whose products are represented on Diodes Incorporated website, harmless against all damages.

Diodes Incorporated does not warrant or accept any liability whatsoever in respect of any products purchased through unauthorized sales channel.

Should Customers purchase or use Diodes Incorporated products for any unintended or unauthorized application, Customers shall indemnify and hold Diodes Incorporated and its representatives harmless against all claims, damages, expenses, and attorney fees arising out of, directly or indirectly, any claim of personal injury or death associated with such unintended or unauthorized application.

Products described herein may be covered by one or more United States, international or foreign patents pending. Product names and markings noted herein may also be covered by one or more United States, international or foreign trademarks.

**LIFE SUPPORT**

Diodes Incorporated products are specifically not authorized for use as critical components in life support devices or systems without the express written approval of the Chief Executive Officer of Diodes Incorporated. As used herein:

A. Life support devices or systems are devices or systems which:

1. are intended to implant into the body, or
2. support or sustain life and whose failure to perform when properly used in accordance with instructions for use provided in the labeling can be reasonably expected to result in significant injury to the user.

B. A critical component is any component in a life support device or system whose failure to perform can be reasonably expected to cause the failure of the life support device or to affect its safety or effectiveness.

Customers represent that they have all necessary expertise in the safety and regulatory ramifications of their life support devices or systems, and acknowledge and agree that they are solely responsible for all legal, regulatory and safety-related requirements concerning their products and any use of Diodes Incorporated products in such safety-critical, life support devices or systems, notwithstanding any devices- or systems-related information or support that may be provided by Diodes Incorporated. Further, Customers must fully indemnify Diodes Incorporated and its representatives against any damages arising out of the use of Diodes Incorporated products in such safety-critical, life support devices or systems.

Copyright © 2011, Diodes Incorporated

[www.diodes.com](http://www.diodes.com)