

CUSTOMER PRINT

PART NUMBER: SF8980-XPG-5XX

NOTES:

1. FINISHED ASSEMBLIES AND LOOSE PARTS BAGGED.
2. LABEL WITH CONXALL PART NUMBER, DATE CODE AND P/N BARCODE PLACED ON BAG
3. SEE DRAWING HPSFMISTD FOR HOLE PATTERNS
4. FOR FIELD INSTALLATION, SEE INSTRUCTION SHEET 2 OF 2.
5. ALL DIMENSIONS ARE REFERENCE EXCEPT THOSE WITH A TOLERANCE
6. DIMENSIONS IN BRACKETS [ ] ARE IN MILLIMETERS
7. CRIMP CONTACT SUPPLIED UNASSEMBLED

CUSTOMER APPROVAL

THIS DOCUMENT CONTAINS CONFIDENTIAL INFORMATION PROPRIETARY TO CONXALL CORPORATION. ANY REPRODUCTION, DISCLOSURE, OR USE OF THIS DOCUMENT / INFORMATION IS EXPRESSLY PROHIBITED UNLESS AUTHORIZED IN WRITING BY CONXALL CORPORATION.

APPROVED BY: \_\_\_\_\_

DATE: \_\_\_\_\_

ASSEMBLY P/ N	NO. OF CONTACT
SF8980-9PG-5XX	(9) # 26
SF8980-10PG-5XX	(10) # 26
SF8980-11PG-5XX	(11) # 26
SF8980-12PG-5XX	(12) # 26
SF8980-13PG-5XX	(13) # 26
SF8980-14PG-5XX	(14) # 26
SF8980-15PG-5XX	(15) # 26
SF8980-16PG-5XX	(16) # 26
SF8980-17PG-5XX	(17) # 26
SF8980-18PG-5XX	(18) # 26

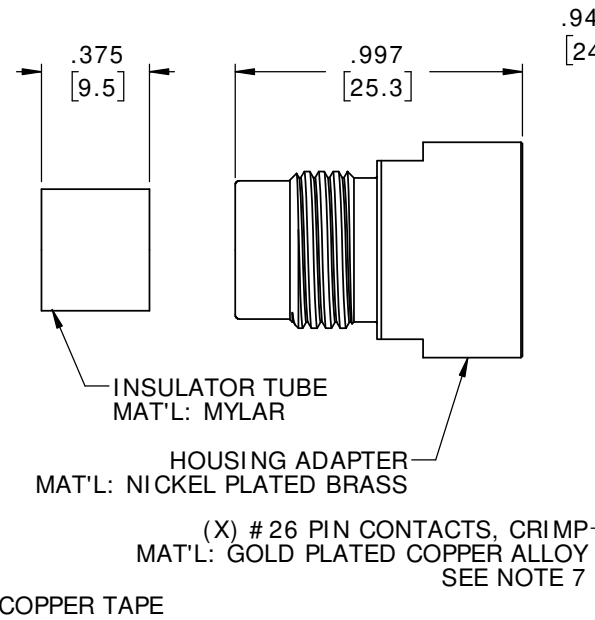
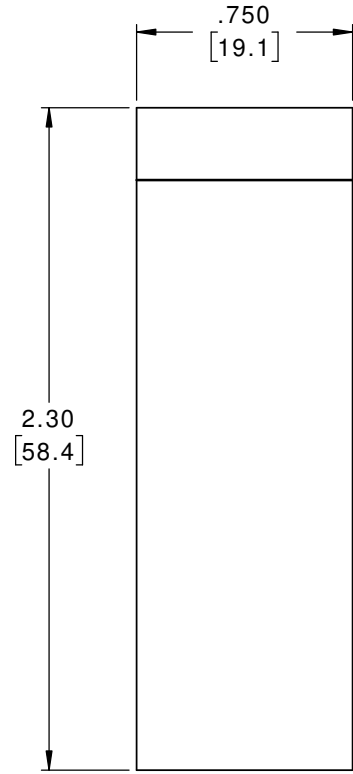
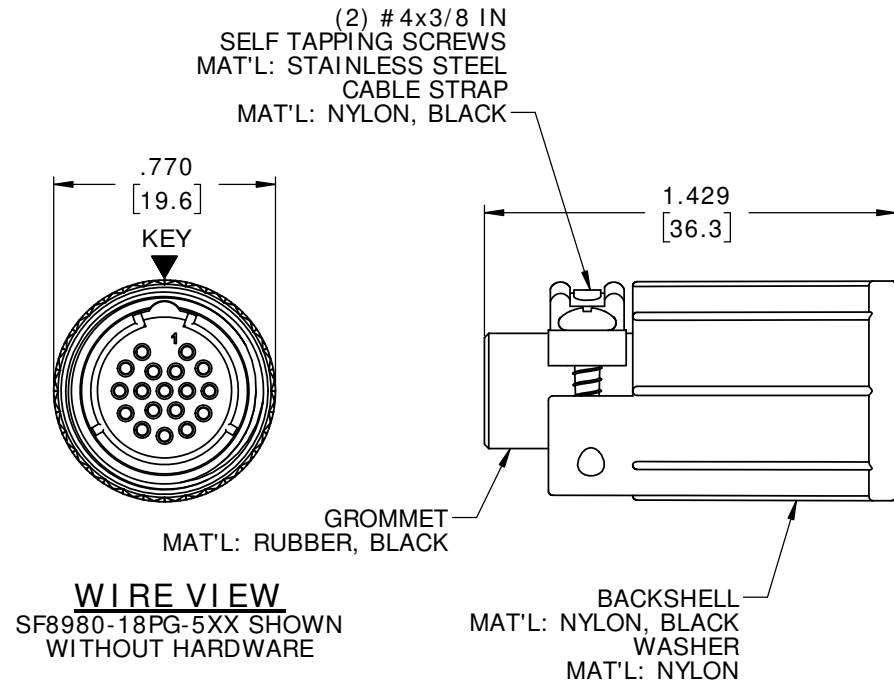

520 = BACKSHELL WITH Ø.220 [5.6] GROMMET I.D.  
530 = BACKSHELL WITH Ø.330 [8.4] GROMMET I.D.

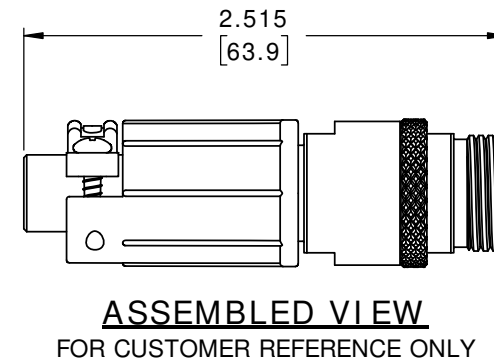
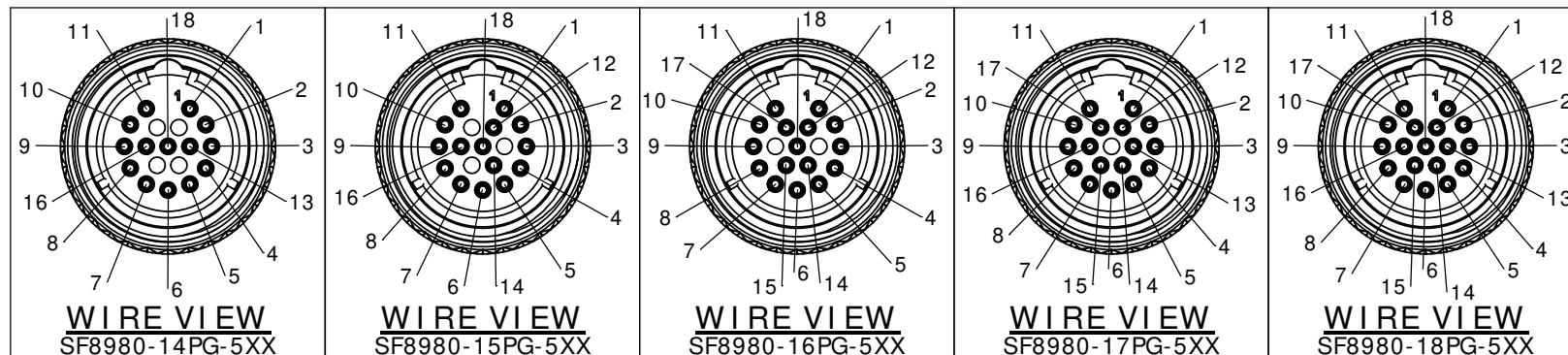
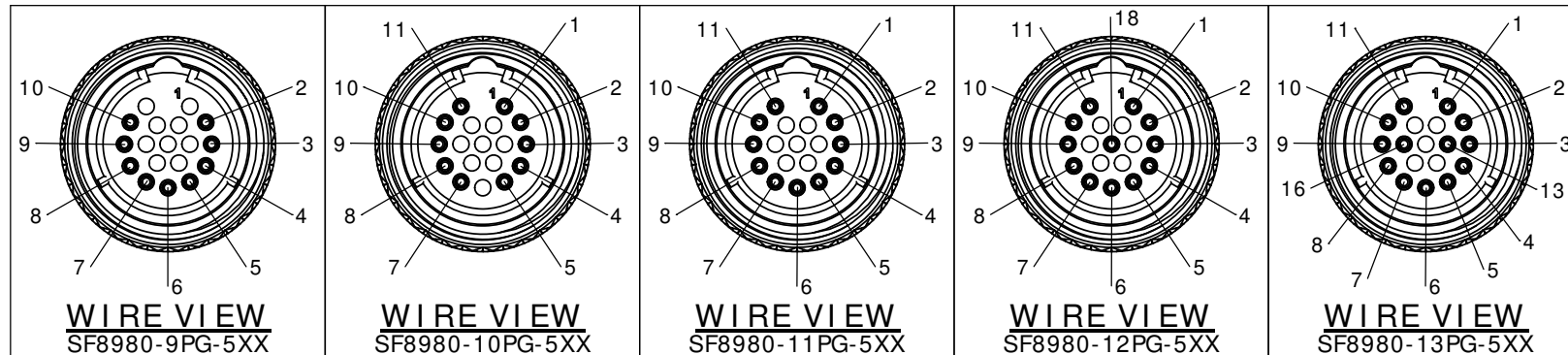
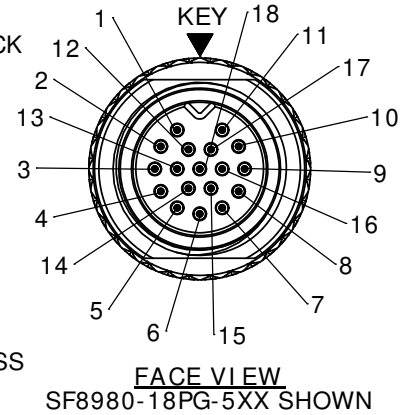
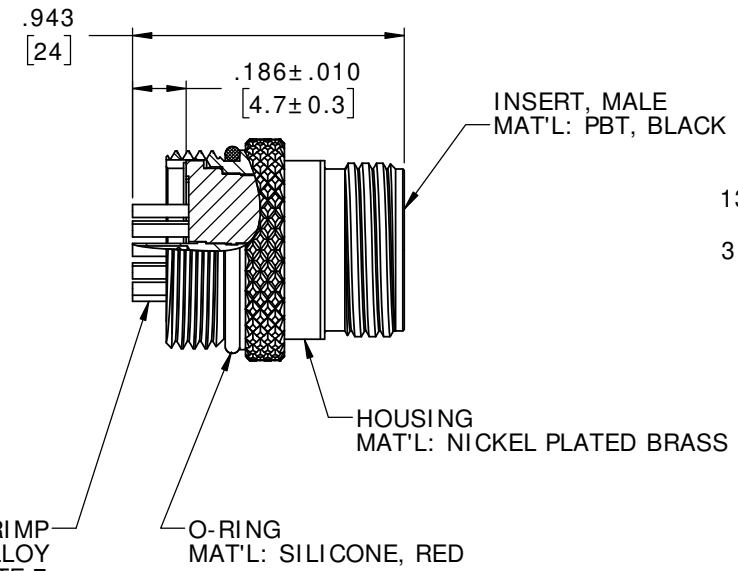

ASSEMBLED VIEW  
FOR CUSTOMER REFERENCE ONLY

A	MA	10-29-19	RELEASED PER PDR 17011
	PNK	9-28-18	RES-79 CHANGED TO RES-78. O-RING 4290S REPLACES SF6290-1.
	PNK	1-30-18	DRAWING CREATED PER PDR 17011
REV.	INIT.	DATE	DESCRIPTION
			ORIG. DRAWN BY: PNK DATE: 1-30-18
ALL INFORMATION ILLUSTRATED IS THE PROPERTY OF CONXALL CORPORATION. UNAUTHORIZED DUPLICATION OR DISTRIBUTION OF THIS DOCUMENT IS PROHIBITED.			
<p>601 E. WILDWOOD VILLA PARK, IL 60181</p>			
SCALE: NTS		SIZE: B	SHEET: 1 OF 2
FILE: SF8980-XPG-5XX		DIRECTORY: SLW	CUSTOMER: SF8980-XPG-5XX
RoHS COMPLIANT			REV: A

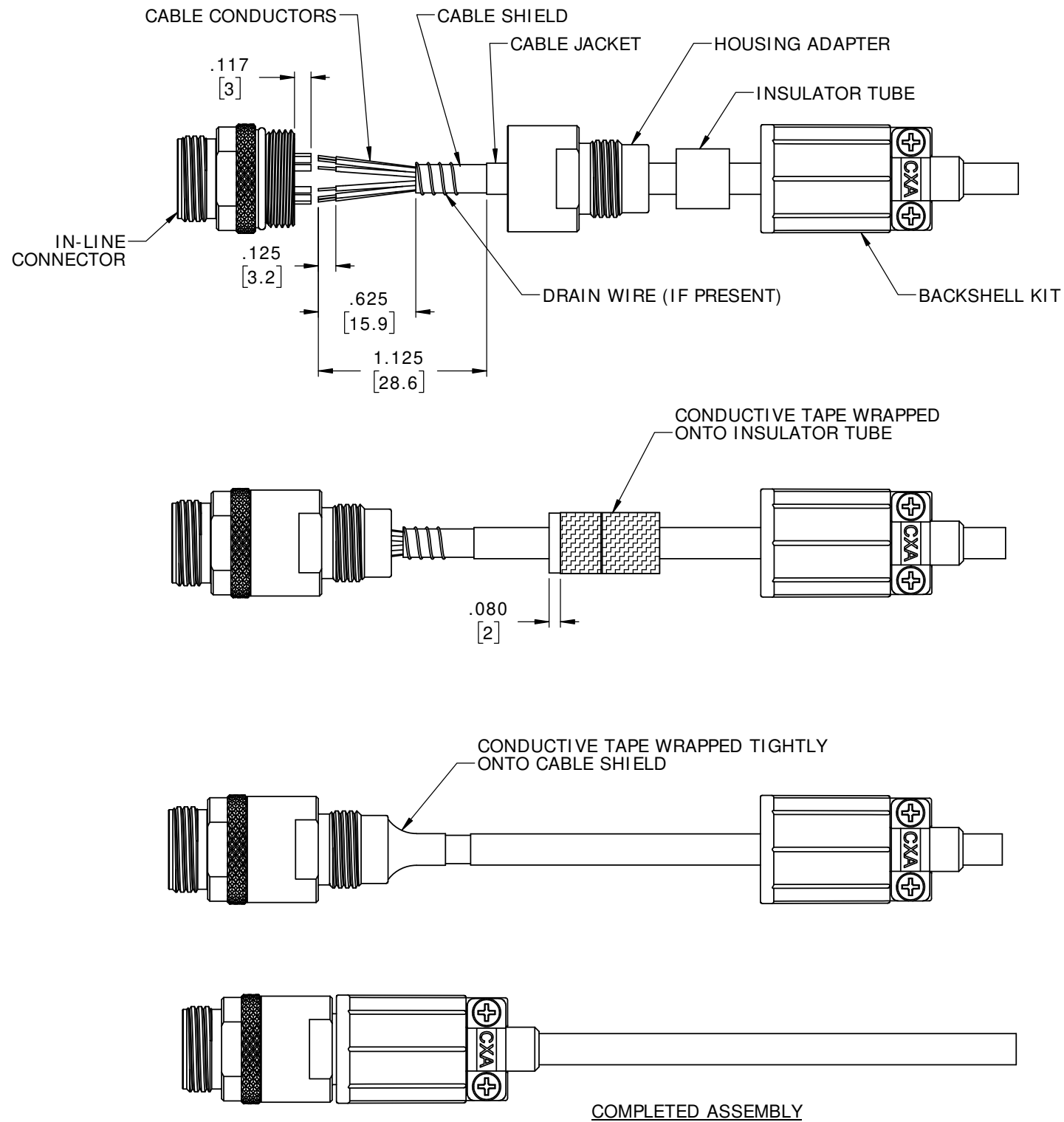

**CABLE WIRING AND ASSEMBLY INSTRUCTIONS:**

- STEP 1.** SLIDE HOUSING ADAPTER, INSULATOR TUBE, AND BACKSHELL KIT, ONTO CABLE IN THE ORDER SHOWN.
- STEP 2.** STRIP CABLE JACKET AND WIRES TO LENGTH. EXCESS CABLE SHIELD MUST BE TRIMMED OR WRAPPED AROUND WIRES. IF PRESENT, USE THE DRAIN WIRE TO WRAP THE CABLE SHIELD IN PLACE.
- STEP 3.** CRIMP WIRES TO CONTACTS.
- STEP 3A.** INSERT THE WIRED CONTACT INTO THE CAVITY AND FIRMLY PUSH THE CONTACT UNTIL IT LOCKS INTO PLACE. GIVE A SLIGHT PULL ON THE WIRE TO INSURE THE CONTACT IS SEATED. THE CONTACT BARREL SHOULD PROJECT BEYOND THE INSERT ACCORDING TO DIMENSION ABOVE.
- STEP 4.** THREAD HOUSING ADAPTER ONTO CONNECTOR AND TIGHTEN TO 5 LB-IN [0.56 N-m] MINIMUM TORQUE.
- STEP 5.** PEEL-OFF THE BACKING OF THE CONDUCTIVE TAPE AND WRAP IT AROUND THE INSULATOR AS SHOWN.
- STEP 6.** SLIDE INSULATOR/CONDUCTIVE TAPE INTO THE BACK OF THE CONNECTOR. FORM FREE END OF CONDUCTIVE TAPE TIGHTLY ONTO THE SHIELD OF THE CABLE.
- STEP 7.** SLIDE AND THREAD THE BACKSHELL KIT ONTO CONNECTOR. TIGHTEN TO 5 LB-IN [0.56 N-m] MINIMUM TORQUE.
- STEP 8.** TIGHTEN THE TWO BACKSHELL SCREWS TO SECURE THE CABLE IN THE BACKSHELL.

MA	04-03-19	RELEASED PER PDR 17011	
A	PNK	9-28-18	RES-79 CHANGED TO RES-78. O-RING 4290S REPLACES SF6290-1.
	PNK	1-30-18	DRAWING CREATED PER PDR 17011
REV.	INIT.	DATE	DESCRIPTION
ALL INFORMATION ILLUSTRATED IS THE PROPERTY OF CONXALL CORPORATION. UNAUTHORIZED DUPLICATION OR DISTRIBUTION OF THIS DOCUMENT IS PROHIBITED.		ORIG. DRAWN BY: PNK	DATE: 1-30-18
UNLESS OTHERWISE SPECIFIED TO TOLERANCES 3 PLACE DECIMALS ±.005 ANGLES ±1° FRACTIONS ±1/16		CHECKED BY:	 601 E. WILDWOOD VILLA PARK, IL 60181
ALL UNITS ARE IN FEET, INCHES, FRACTION OF INCHES AND DECIMALS		APPROVED BY:	
SCALE	SIZE	SHEET	TITLE: CABLE-TO-CABLE ASSEMBLY (9-18) #26 PIN CONTACTS, CRIMP SHIELDED MINI-CON-X STANDARD PRODUCT
NTS	B	2 OF 2	CUSTOMER: SF8980-XPG-5XX
FILE:	DIRECTORY:	PART NUMBER:	REV
FILE NAME	SLW	SF8980-XPG-5XX	A