

PAGE 1/2

ISSUE 21.01.15

SERIE : SPnT

PART NUMBER : R573433600

RF CHARACTERISTICS

Number of ways : **6**
 Frequency range : **0 - 18 GHz**
 Impedance : **50 Ohms**

Frequency (GHz)	DC - 3	3 - 8	8 - 12.4	12.4 - 18
VSWR max	1.20	1.30	1.40	1.50
Insertion loss max	0.20 dB	0.30 dB	0.40 dB	0.50 dB
Isolation min	80 dB	70 dB	60 dB	60 dB
Average power (*)	240 W	150 W	120 W	100 W

ELECTRICAL CHARACTERISTICS

Actuator : **LATCHING**
 Nominal current ** : **125 mA / RESET : 750 mA ******
 Actuator voltage (Vcc) : **28V (24 to 30V) / NEGATIVE COMMON**
 Terminals : **solder pins (250°C max. / 30 sec.)**
 Indicator rating : **1 W / 30 V / 100 mA**

MECHANICAL CHARACTERISTICS

Connectors : **SMA female per MIL-C 39012**
 Life : **5.000.000 cycles per position**
 Switching Time*** : **< 15 ms**
 Construction : **Splashproof**
 Weight : **< 180 g**

ENVIRONMENTAL CHARACTERISTICS

Operating temperature range : **-40°C to +85°C**
 Storage temperature range : **-55°C to +85°C**

(* Average power at 25°C per RF Path)

(** At 25° C ±10%)

(*** Nominal voltage ; 25° C)

(**** Reset : supply voltage time 1sec. max. / duty cycle 10%)



PAGE 2/2

ISSUE 21.01.15

SERIE : SPnT

PART NUMBER : R573433600

DRAWING

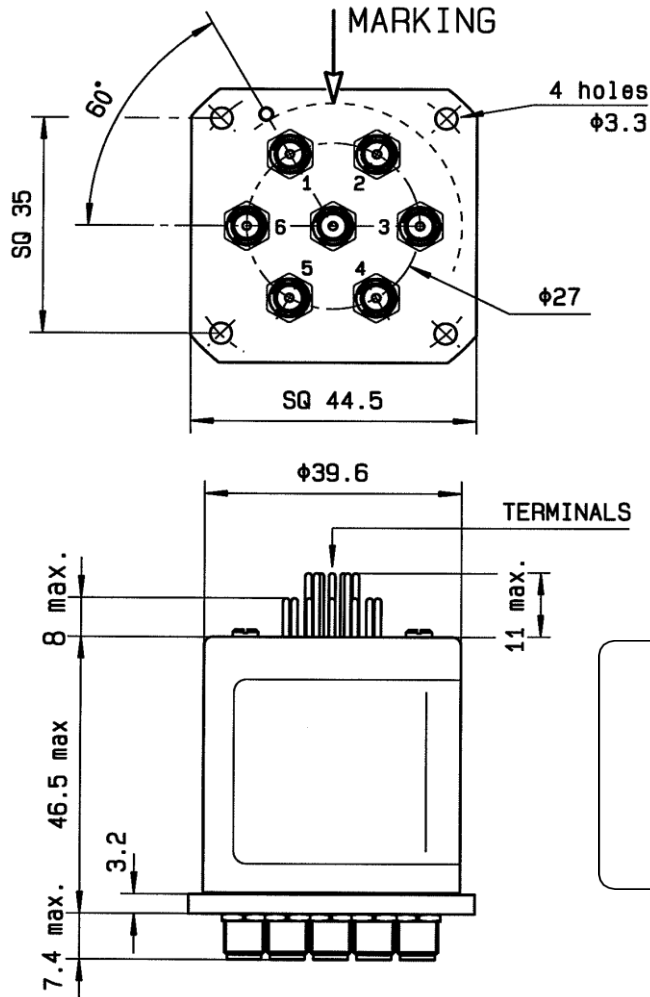

Voltage	RF Continuity	Ind.
-C +RESET	All ports open	- -
-C +1	IN ↔ 1	D.E
-C +2	IN ↔ 2	D.F
-C +3	IN ↔ 3	D.G
-C +4	IN ↔ 4	D.H
-C +5	IN ↔ 5	D.I
-C +6	IN ↔ 6	D.J

LABEL

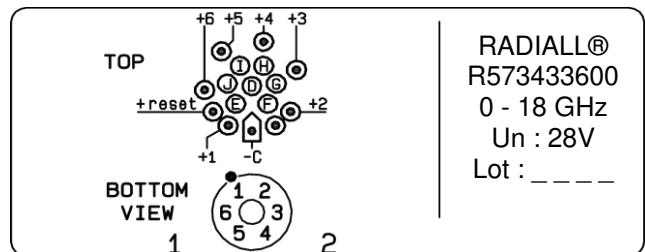

General tolerances : ±0.5 mm

SCHEMATIC DIAGRAM

