

**THIS PRODUCT MANUFACTURED WITH LEAD-FREE PROCESSING**

**DESIGNED & DIMENSIONED IN MILLIMETERS [INCHES]**

DO NOT SCALE FROM THIS PRINT

**SMP-J-C-XX-ST-CA7**

- GENDER -J: JACK
- TYPE -C: CABLE
- TERMINATION -CA7: CCA-405 CABLE (RG 405 SEMI FLEXIBLE CABLE)
- ORIENTATION -ST: STRAIGHT
- PLATING SPECIFICATION
  - HG: HEAVY GOLD / GOLD
    - 30µ" Au / 50µ" Ni MIN ON PIN
    - 10µ" Au / 50µ" Ni MIN ON OUTER CONTACT
  - GF: GOLD / FLASH GOLD
    - 10µ" Au / 50µ" Ni MIN ON PIN
    - 3µ" Au / 50µ" Ni MIN ON OUTER CONTACT (SEE TABLE 1)

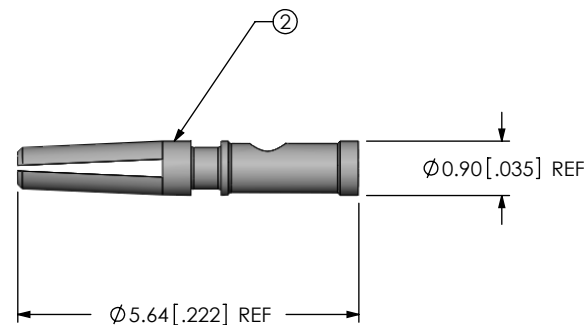
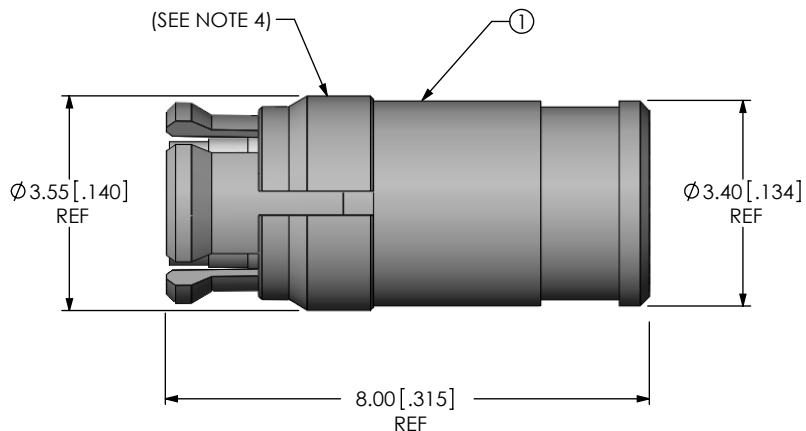

NOTES:

1.  $\text{\textcircled{1}}$  REPRESENTS A CRITICAL DIMENSION.
2. PRODUCT TO BE PACKAGED PER PACKING STANDARD CO-HD-WI-3040-M. TRAY: TY-SMA001-1 COVER: TY-SMA001-2 200 PARTS PER TRAY (2 PARTS PER POCKET)
3. SOCKET TO BE PACKAGED SEPARATELY. **A**
4. THE RING IS LOOSE AND CAN MOVE, 1.5 LBS MIN FORCE TO REMOVE. **A**

**TABLE 1**

ITEM	COMPONENT	-HG	-GF
1	SUB ASSEMBLY	SUB-SMP-J-C-GF-ST-CA7	SUB-SMP-J-C-FN-ST-CA7
2	SOCKET	SMP-J-C-H-ST-CA7-SKT	SMP-J-C-G-ST-CA7-SKT

UNLESS OTHERWISE SPECIFIED, DIMENSIONS ARE IN MILLIMETERS. TOLERANCES ARE: DECIMALS      ANGLES X.X: ±0.3 [.01]      5° X.XX: ±0.13 [.005] X.XXX: ±0.051 [.0020]	<b>PROPRIETARY NOTE</b> THIS DOCUMENT CONTAINS INFORMATION CONFIDENTIAL AND PROPRIETARY TO SAMTEC, INC. AND SHALL NOT BE REPRODUCED OR TRANSFERRED TO OTHER DOCUMENTS OR DISCLOSED TO OTHERS OR USED FOR ANY PURPOSE OTHER THAN THAT WHICH IT WAS OBTAINED WITHOUT THE EXPRESSED WRITTEN CONSENT OF SAMTEC, INC.	 520 PARK EAST BLVD, NEW ALBANY, IN 47150 PHONE: 812-944-6733    FAX: 812-948-5047 e-Mail: info@SAMTEC.com    code 55322	
		MATERIAL: DO NOT SCALE DRAWING      SHEET SCALE: 8:1 SUB ASSEMBLY: BODY & RING: BeCu INSULATOR: PTFE SOCKET: BeCu INSULATOR: PTFE	
<b>A</b>		DESCRIPTION: SMP ST JACK FOR CCA-405 - 50 OHM	
		DWG. NO. SMP-J-C-XX-ST-CA7	
BY: J. BROWNING 02/08/2011		SHEET 1 OF 2	



IN-PROCESS 1  
STRIP AND TIN INNER CONDUCTOR

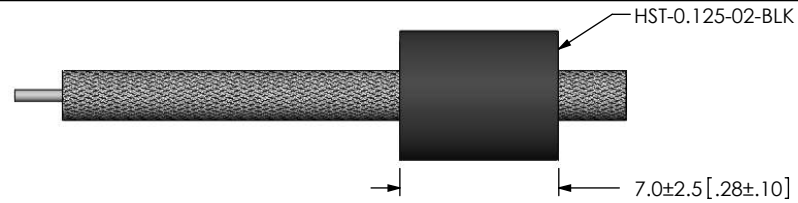

IN-PROCESS 2  
ADD HEAT SHRINK

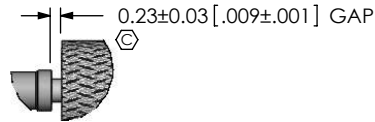

DETAIL 'C'  
SCALE 6:1



IN-PROCESS 3  
SOLDER SIGNAL CONTACT

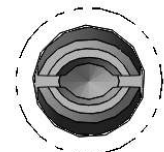

DETAIL 'B'  
SCALE 16:1

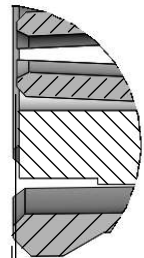

DETAIL 'A'  
SCALE 16:1



IN-PROCESS 4  
ADD SUB ASSEMBLY & SOLDER BRAID



IN-PROCESS 5  
APPLY HEAT TO SHRINK TUBING

**PROPRIETARY NOTE**  
THIS DOCUMENT CONTAINS INFORMATION CONFIDENTIAL AND PROPRIETARY TO SAMTEC, INC. AND SHALL NOT BE REPRODUCED OR TRANSFERRED TO OTHER DOCUMENTS OR DISCLOSED TO OTHERS OR USED FOR ANY PURPOSE OTHER THAN THAT WHICH IT WAS OBTAINED WITHOUT THE EXPRESSED WRITTEN CONSENT OF SAMTEC, INC.

DO NOT SCALE DRAWING

SHEET SCALE: 8:1

**samtec**

520 PARK EAST BLVD, NEW ALBANY, IN 47150  
PHONE: 812-944-6733 FAX: 812-948-5047  
e-Mail info@SAMTEC.com code 55322

DESCRIPTION:  
SMP ST JACK FOR CCA-405 - 50 OHM

DWG. NO.  
SMP-J-C-XX-ST-CA7

BY: J. BROWNING 02/08/2011 SHEET 2 OF 2