

100-4*25G Active Optical Cable (QSFP28-4*SFP28)

Features

- Support 4x25GBASE-SR application
- Compliant to QSFP28 MSA SFF-8636 and SFP28 MSA SFF-8431 and SFF-8472
- Multi rate of up to 25.78125Gbps per lane
- Transmission distance up to 70M(OM3) and 100M(OM4)
- +3.3V single power supply
- Low power consumption
- UL certification cables (optional)
- Operating temp Commercial: 0°C to +70 °C
- RoHS compliant

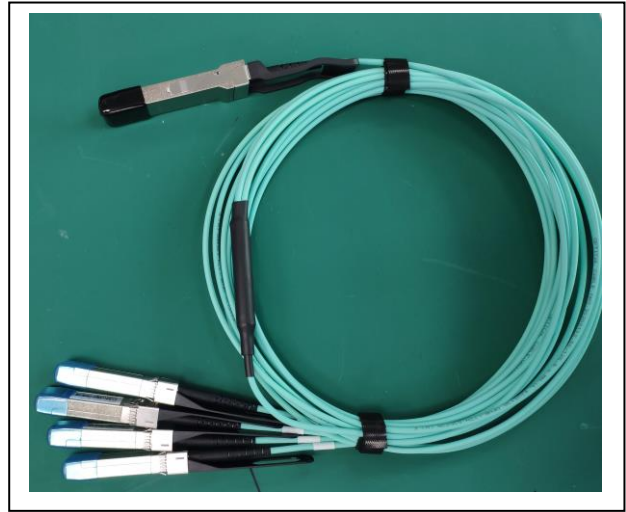

Applications

- 4x25Gbe-SR
- Other optical links

Absolute Maximum Ratings

Table1- Absolute Maximum Ratings

Parameter	Symbol	Min.	Typical	Max.	Unit	Notes
Supply Voltage	V _{CC3}	-0.5	-	+3.6	V	
Storage Temperature	T _s	-10	-	+70	°C	
Operating Humidity	RH	+5	-	+85	%	1

Note: 1 No condensation

Recommended Operating Conditions

Table 2- Recommended operating Conditions

Parameter	Symbol	Min.	Typical	Max.	Unit	Notes
Operating Temperature	T _c	0	-	+70	°C	
Power Supply Voltage	V _{CC}	3.14	3.3	3.47	V	
Power Dissipation per QSFP28	P _d	-	-	2.5	W	
Power Dissipation per SFP28	P _d	-	-	1.0	W	1
Bit Rate per Lane	BR	10.3125	25.78125	-	Gbps	

Note: 1 Per terminal

Electrical Characteristics

Table 3- Electrical Characteristics for QSFP28

Parameter		Symbol	Min.	Typ.	Max.	Units	Notes
ModSelL	Module Select	V_{OL}	0	-	0.8	V	
	Module Unselect	V_{OH}	2.5	-	V_{CC}	V	
LPMode	Low Power Mode	V_{IL}	0	-	0.8	V	
	Normal Operation	V_{IH}	2.5	-	$V_{CC}+0.3$	V	
ResetL	Reset	V_{IL}	0	-	0.8	V	
	Normal Operation	V_{IH}	2.5	-	$V_{CC}+0.3$	V	
ModPrsL	Normal Operation	V_{OL}	0	-	0.4	V	
IntL	Interrupt	V_{OL}	0	-	0.4	V	
	Normal Operation	V_{OH}	2.4	-	V_{CC}	V	
Electrical Transmitter Characteristics							
Differential Data Input Swing		$V_{in,P-P}$	200	-	1600	mV	
Output Differential Impedance		Z_{IN}	90	100	110	Ω	
Electrical Receiver Characteristics							
Differential Data Output Swing		V_{out}	200	-	800	mV _{pp}	
Bit Error Rate		BER			E-12		1
Input Differential Impedance		Z_D	90	100	110	Ω	

Note: 1 PRBS2^31-1@25.78125Gbps

Table 4- Electrical Characteristics for SFP28

Parameter		Symbol	Min.	Typ.	Max.	Units	Notes
Electrical Transmitter Characteristics							
Differential Data Input Swing		$V_{in,P-P}$	200	-	1600	mV _{pp}	
Input Differential Impedance		Z_{IN}	90	100	110	Ω	
Tx_Fault	Normal Operation	V_{OL}	0	-	0.8	V	
	Transmitter Fault	V_{OH}	2.0	-	V_{CC}	V	
Tx_Disable	Normal Operation	V_{IL}	0	-	0.8	V	
	Laser Disable	V_{IH}	2.0	-	$V_{CC}+0.3$	V	
Electrical Receiver Characteristics							
Differential Data Output		V_{out}	400	-	800	mV	
Bit Error Rate		BER	-	-	E-12	-	
Output Differential Impedance		Z_D	90	100	110	Ω	
Rx_LOS	Normal Operation	V_{OL}	0	-	0.8	V	
	Lose Signal	V_{OH}	2.0	-	V_{CC}	V	

Pin arrangement

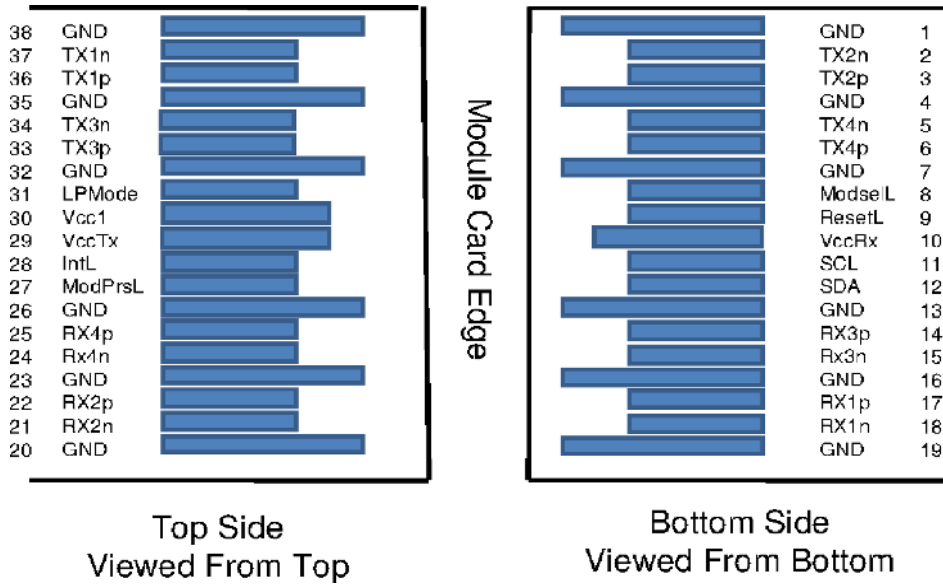

Figure 1, Pin View for QSFP28

Table 5- Pin Function Definitions for QSFP28

Pin	Symbol	Name/Description	Notes
1	GND	Ground	1
2	Tx2n	Transmitter Inverted Data Input	
3	Tx2p	Transmitter Non-Inverted Data Input	
4	GND	Ground	1
5	Tx4n	Transmitter Inverted Data Input	
6	Tx4p	Transmitter Non-Inverted Data Input	
7	GND	Ground	1
8	ModSeL	Module Select	
9	ResetL	Module Reset	
10	Vcc Rx	+3.3V Power Supply Receiver	
11	SCL	2-wire serial interface clock	
12	SDA	2-wire serial interface data	
13	GND	Ground	1
14	Rx3p	Receiver Non-Inverted Data Output	
15	Rx3n	Receiver Inverted Data Output	
16	GND	Ground	1
17	Rx1p	Receiver Non-Inverted Data Output	
18	Rx1n	Receiver Inverted Data Output	
19	GND	Ground	1
20	GND	Ground	1
21	Rx2n	Receiver Inverted Data Output	
22	Rx2p	Receiver Non-Inverted Data Output	
23	GND	Ground	1
24	Rx4n	Receiver Inverted Data Output	

Pin	Symbol	Name/Description	Notes
25	Rx4p	Receiver Non-Inverted Data Output	
26	GND	Ground	1
27	ModPrsL	Module Present	
28	IntL	Interrupt	
29	Vcc Tx	+3.3V Power supply transmitter	
30	Vcc1	+3.3V Power supply	
31	LPMODE	Low Power Mode	
32	GND	Ground	1
33	Tx3p	Transmitter Non-Inverted Data Input	
34	Tx3n	Transmitter Inverted Data Input	
35	GND	Ground	1
36	Tx1p	Transmitter Non-Inverted Data Input	
37	Tx1n	Transmitter Inverted Data Input	
38	GND	Ground	1

Note: 1. Circuit ground is internally isolated from chassis ground.

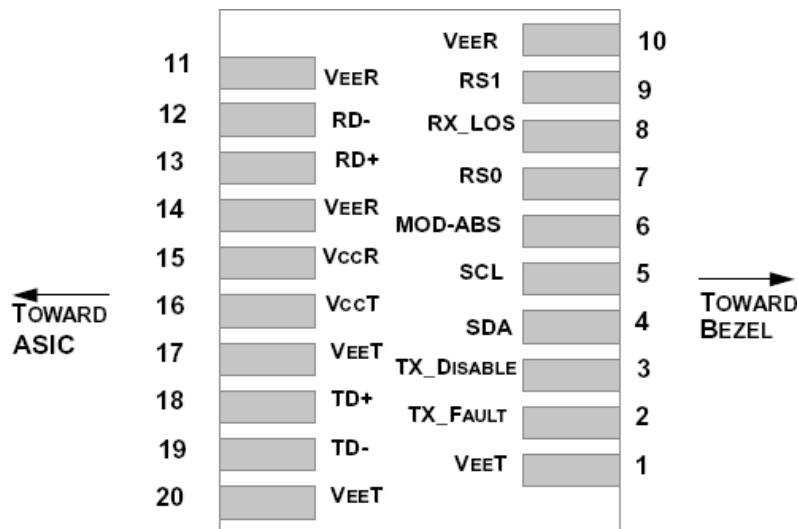

Figure 2, Pin View for SFP28

Table 6-Pin Function Definitions

Pin	Symbol	Name/Description	Notes
1	VEET	Module Transmitter Ground	1
2	TX_FAULT	Module Transmitter Fault	2
3	TX_DISABLE	Transmitter Disable; Turns off transmitter laser output	3
4	SDA	2-Wire Serial Interface Data Line (MOD-DEF2)	
5	SCL	2-Wire Serial Interface Clock (MOD-DEF1)	
6	MOD_ABS	Module Absent, connected to VEET or VEER in the module	2
7	RS0	Rate Select 0, optionally controls SFP+ module receiver	4
8	RX_LOS	Receiver Loss of Signal Indication (In FC designated as Rx_LOS and in Ethernet designated as NOT Signal Detect)	2
9	RS1	Rate Select 1, optionally controls SFP+ module transmitter	4

Pin	Symbol	Name/Description	Notes
10	V _{EE} R	Module Receiver Ground	1
11	V _{EE} R	Module Receiver Ground	1
12	RD-	Receiver Inverted Data Output	
13	RD+	Receiver Non-Inverted Data Output	
14	V _{EE} R	Module Receiver Ground	1
15	V _{CC} R	Module Receiver 3.3 V Supply	
16	V _{CC} T	Module Transmitter 3.3 V Supply	
17	V _{EE} T	Module Transmitter Ground	1
18	TD+	Transmitter Non-Inverted Data Input	
19	TD-	Transmitter Inverted Data Input	
20	V _{EE} T	Module Transmitter Ground	1

Note:

1. The module ground pins are isolated from the module case.
2. The pins shall be pulled up with 4.7K-10Kohms to a voltage between 3.14V and 3.46V on host board.
3. The pin is pulled up to VCCT with a 4.7K-10KΩ resistor in the module.
4. See SFF-8472 Rev12.2 Table 10-2.

Recommended Circuit

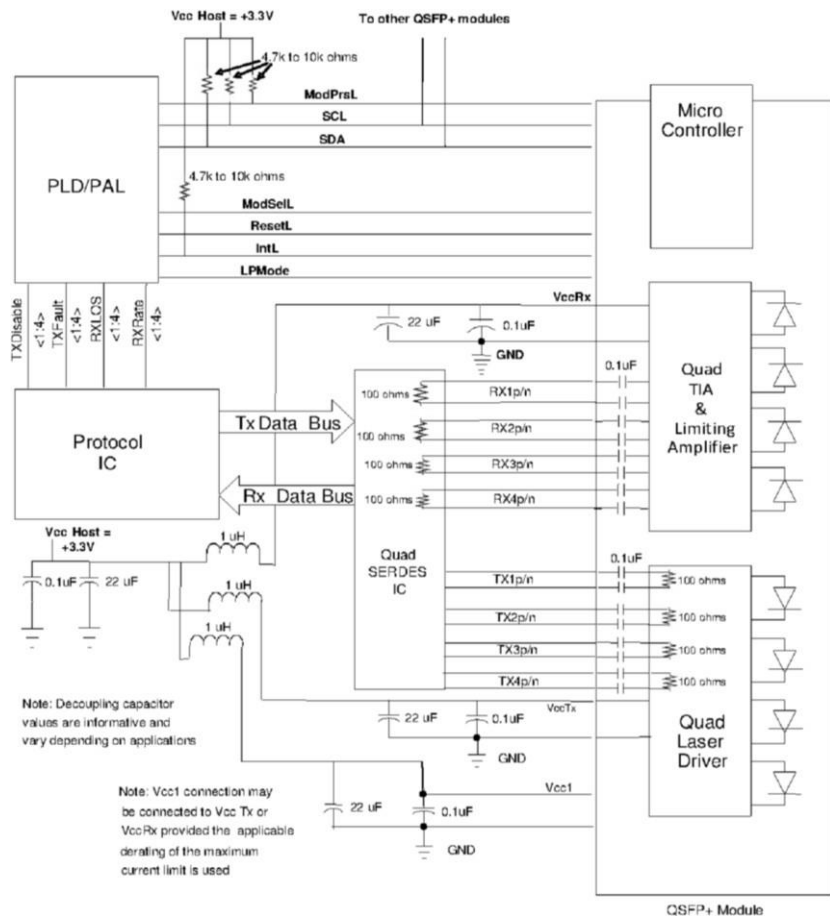

Figure 3, Recommended Interface Circuit for QSFP28

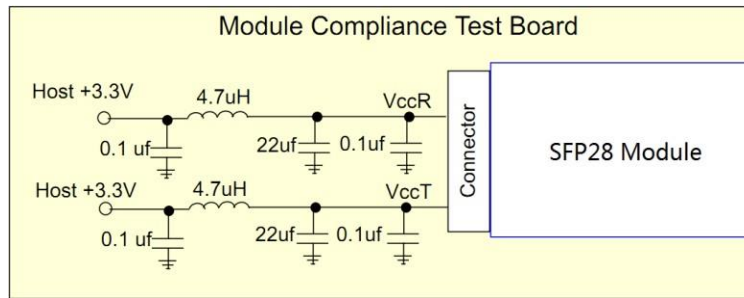

Figure 4, Recommended Host Board Power Supply Circuit for SFP28

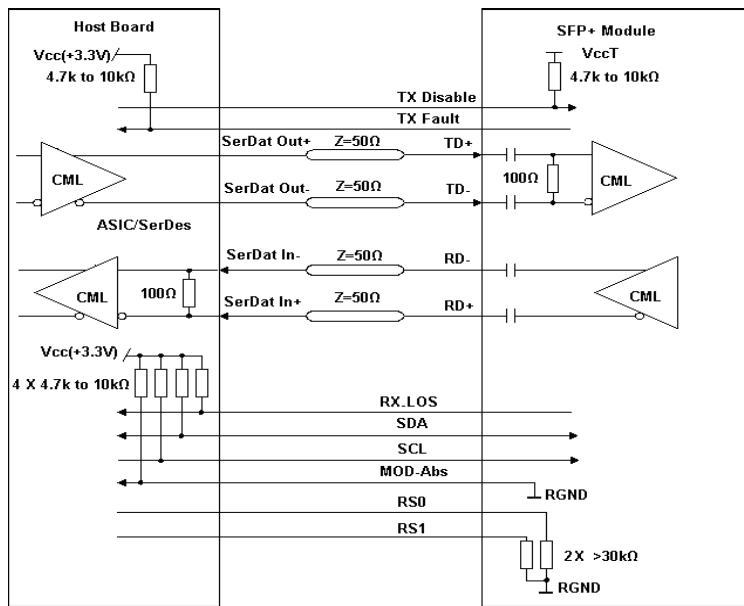

Figure 5, Recommended Interface Circuit for SFP28

Monitoring Specification

2-Wire Serial Address 1010000x			
Lower Page 00h			
0	Identifier		
1- 2	Status		
3- 21	Interrupt Flags		
22- 33	Free Side Device Monitors		
34- 81	Channel Monitors		
82- 85	Reserved		
86- 98	Control		
99	Reserved		
100-104	Hardware Interrupt Pin Masks		
105-106	Vendor Specific		
107	Reserved		
108-110	Free Side Device Properties		
111-112	Assigned for use by PCI Express		
113	Free Side Device Properties		
114-118	Reserved		
119-122	Password Change Entry Area (Optional)		
123-126	Password Entry Area (Optional)		
127	Page Select Byte		

Upper Page 00h	Optional Page 01h	Optional Page 02h	Optional Page 03h
128 Identifier	128 CC_APPS	128-255 User EEPROM Data	128-175 Free Side Device Thresholds
129-191 Base ID Fields	129 AST Table Length (TL)		
	130-131 Application Code Entry 0		
	132-133 Application Code Entry 1		
	134-253 other entries		
192-223 Extended ID			176-223 Channel Thresholds
224-255 Vendor Specific ID			224 Tx EQ & Rx Emphasis Magnitude ID
			225 RX output amplitude indicators
			226-241 Channel Controls
			242-251 Channel Monitor Masks
	254-255 Application Code Entry TL		252-255 Reserved

Figure 6, Memory Map for QSFP28

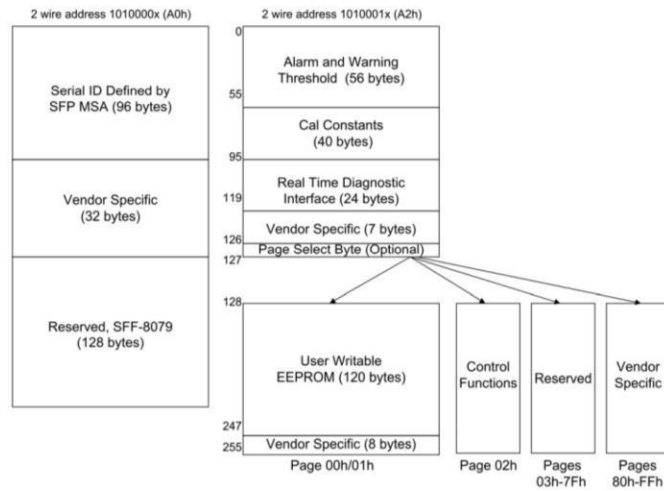

Figure 7, Memory Map for SFP28

Mechanical

Unit mm

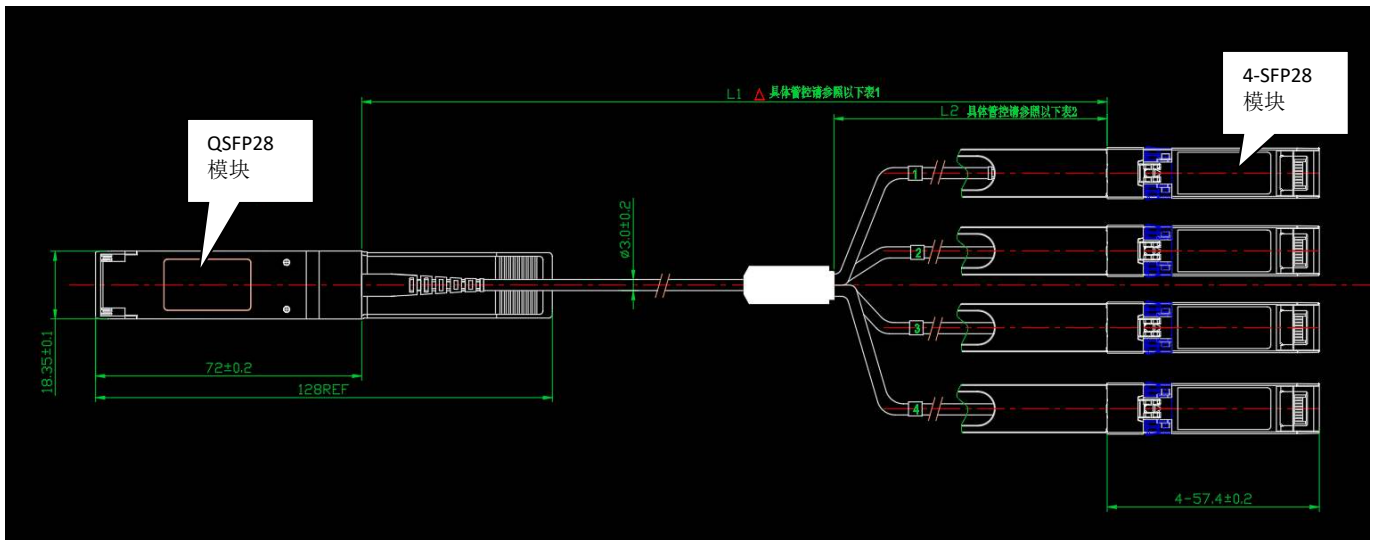

Figure 8, Mechanical Diagram

Table 7- Cable Length

Cable Length L1 (Unit: m)	Tolerant (Unit: cm)
$L1 \leq 1.0$	+7/-0
$1.0 < L1 < 7.0$	+10/-0
$7.0 \leq L1$	+2%L1/-0

Table 8- Breakout Cable Nominal Length

Length L1 (Unit: m)	Length L2 (Unit: m)
$L1 \leq 1$	0.5
$1 < L1$	1

Warnings

Handling Precautions: This device is susceptible to damage as a result of electrostatic discharge (ESD).

A static free environment is highly recommended. Follow guidelines according to proper ESD procedures.

Laser Safety: Radiation emitted by laser devices can be dangerous to human eyes. Avoid eye exposure to direct or indirect radiation.