

## Features

- ESD protection for 4 high-speed I/O channels
- Provide transient protection for each line to IEC 61000-4-2 (ESD)  $\pm 20\text{kV}$  (air),  $\pm 20\text{kV}$  (contact)  
IEC 61000-4-4 (EFT) 40A (5/50ns)  
IEC 61000-4-5 (Lightning) 7A (8/20 $\mu\text{s}$ )
- For low operating voltage of 5V and below
- Ultra-low capacitance: 0.5pF typical
- Fast turn-on and ultra-low clamping voltage
- Array of ESD rated diodes with internal equivalent TVS (Transient Voltage Suppression) diode
- Solid-state silicon-avalanche and active circuit triggering technology
- **Green part**

## Applications

- HDMI 1.3, 1.4, and 2.0 version
- DisplayPort interface
- USB 2.0 and 3.0 interfaces
- USB Type-C interface
- SATA and eSATA interfaces
- Handheld portable applications

## Description

AZ1145-04F is a design which includes ESD rated diode arrays to protect high-speed data interfaces. The AZ1145-04F has been specifically designed to protect sensitive components which are connected to data and transmission lines from over-voltage damage caused by Electrostatic Discharging (ESD), Electrical Fast Transients (EFT), Lightning, and Cable Discharge Event (CDE).

AZ1145-04F is a unique design which includes ESD rated, ultra-low capacitance steering diodes and a unique design of clamping cell which is an equivalent TVS diode in a single package. During transient conditions, the steering diodes direct the transient to either the internal ESD line or to ground line. The internal unique design of clamping cell prevents over-voltage on the internal ESD line and on the I/O line, which is protecting any downstream components.

AZ1145-04F may be used to meet the ESD immunity requirements of IEC 61000-4-2, Level 4 ( $\pm 15\text{kV}$  air,  $\pm 8\text{kV}$  contact discharge).

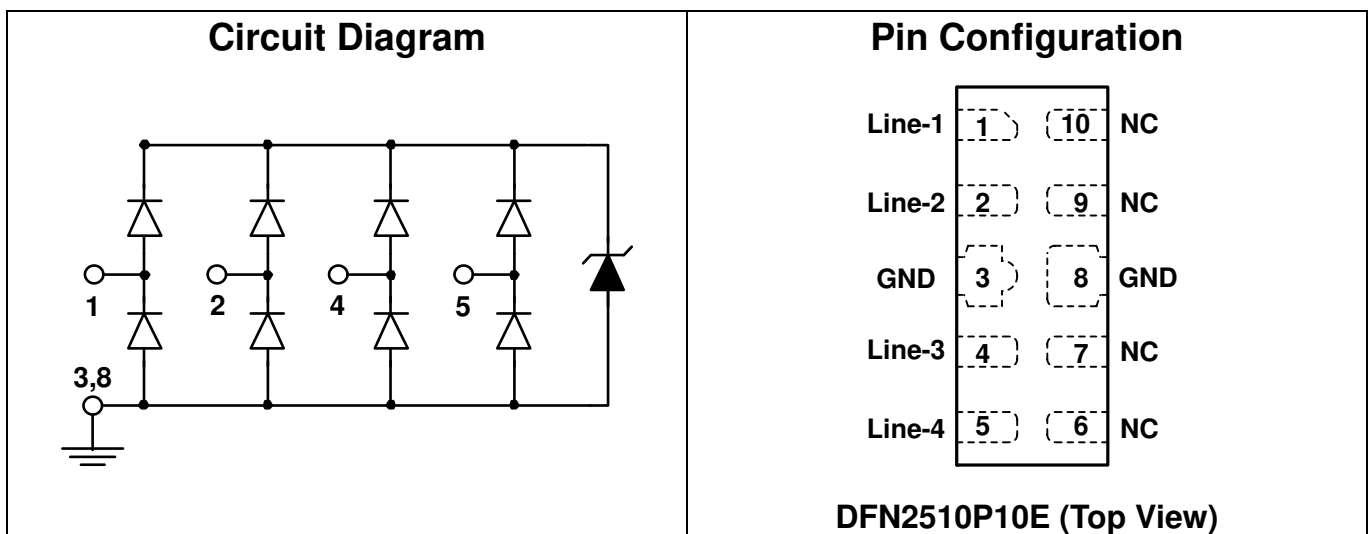

## Specifications

Absolute Maximum Ratings ( $T_A = 25^\circ\text{C}$ , unless otherwise specified)			
Parameter	Symbol	Rating	Unit
Peak Pulse Current ( $t_p = 8/20\mu\text{s}$ )	$I_{PP}$	7	A
Operating Voltage (I/O pin-GND)	$V_{DC}$	5.5	V
ESD per IEC 61000-4-2 (Air)	$V_{ESD-1}$	$\pm 20$	kV
ESD per IEC 61000-4-2 (Contact)	$V_{ESD-2}$	$\pm 20$	
Lead Soldering Temperature	$T_{SOL}$	260 (10 sec.)	$^\circ\text{C}$
Operating Temperature	$T_{OP}$	-55 to +125	$^\circ\text{C}$
Storage Temperature	$T_{STO}$	-55 to +150	$^\circ\text{C}$

Electrical Characteristics						
Parameter	Symbol	Condition	Min	Typ	Max	Unit
Reverse Stand-Off Voltage	$V_{RWM}$	Pin-1,-2,-4,-5 to pin-3,-8, $T = 25^\circ\text{C}$ .			5	V
Channel Leakage Current	$I_{CH-Leak}$	$V_{Pin-1,-2,-4,-5} = 5.0\text{V}$ , $V_{Pin-3,-8} = 0\text{V}$ , $T = 25^\circ\text{C}$ .			1	$\mu\text{A}$
Reverse Breakdown Voltage	$V_{BV}$	$I_{BV} = 1\text{mA}$ , pin-1,-2,-4,-5 to pin-3,-8, $T = 25^\circ\text{C}$ .	6		9	V
Forward Voltage	$V_F$	$I_F = 15\text{mA}$ , pin-3,-8 to pin-1,-2,-4,-5, $T = 25^\circ\text{C}$ .	0.6		1.2	V
Surge Clamping Voltage	$V_{CL-surge}$	$I_{PP} = 5\text{A}$ , $T = 25^\circ\text{C}$ , any I/O pin to GND.		7		V
ESD Clamping Voltage (Note 1)	$V_{CL-ESD}$	IEC 61000-4-2 +8kV ( $I_{TLP} = 16\text{A}$ ), contact mode, $T = 25^\circ\text{C}$ , any I/O pin to GND.		9		V
ESD Dynamic Turn-on Resistance	$R_{dynamic}$	IEC 61000-4-2, 0~+8kV, $T = 25^\circ\text{C}$ , contact mode, any I/O pin to GND.		0.2		$\Omega$
Channel Input Capacitance	$C_{IN}$	$V_{pin-3,-8} = 0\text{V}$ , $V_{IN} = 2.5\text{V}$ , $f = 1\text{MHz}$ , $T = 25^\circ\text{C}$ , any I/O pin to GND.		0.5	0.65	pF
Channel to Channel Input Capacitance	$C_{IO-to-IO}$	$V_{pin-3,-8} = 0\text{V}$ , $V_{IN} = 2.5\text{V}$ , $f = 1\text{MHz}$ , $T = 25^\circ\text{C}$ , between I/O pins.		0.05	0.1	pF

Note 1: ESD Clamping Voltage was measured by Transmission Line Pulsing (TLP) System.

TLP conditions:  $Z_0 = 50\Omega$ ,  $t_p = 100\text{ns}$ ,  $t_r = 1\text{ns}$ .



## Typical Characteristics

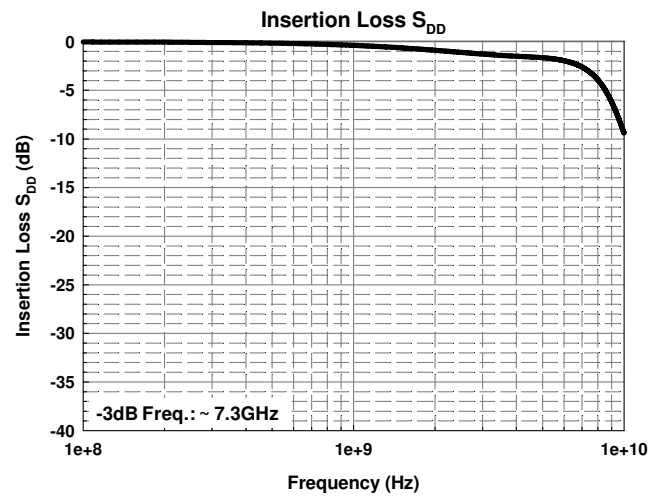
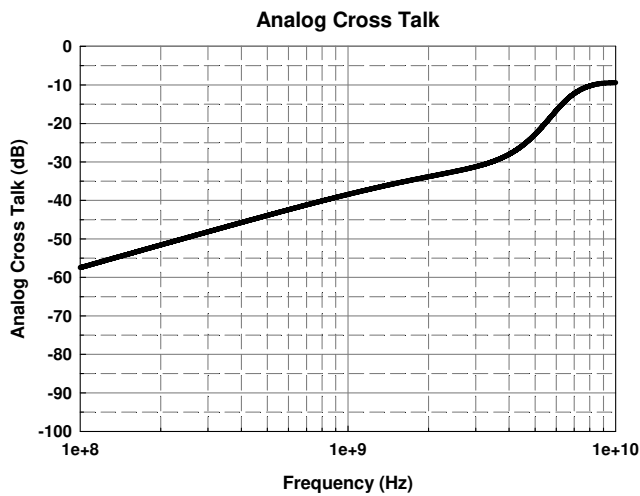
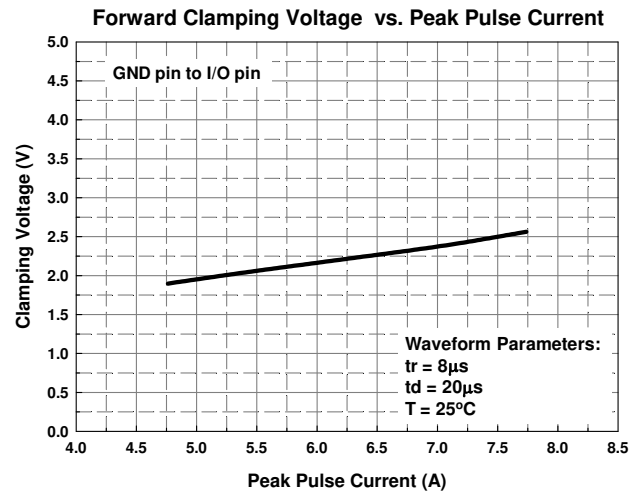
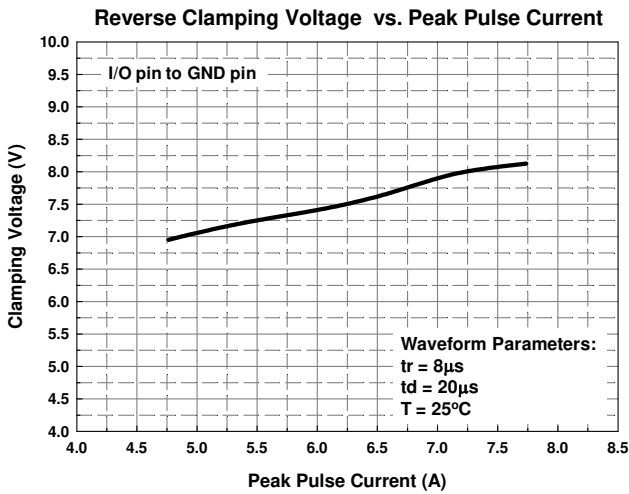
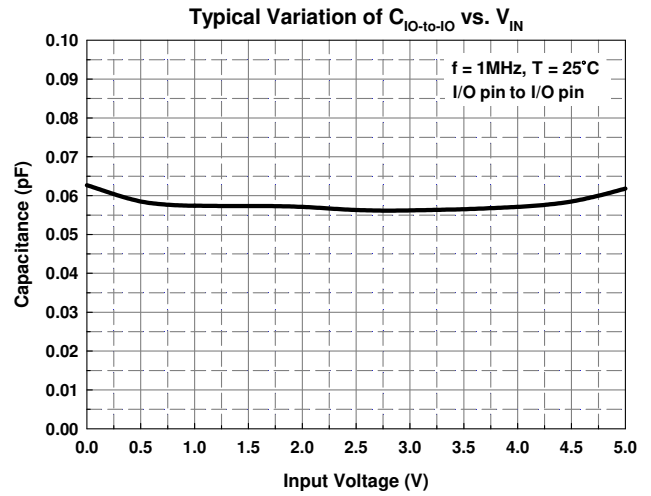
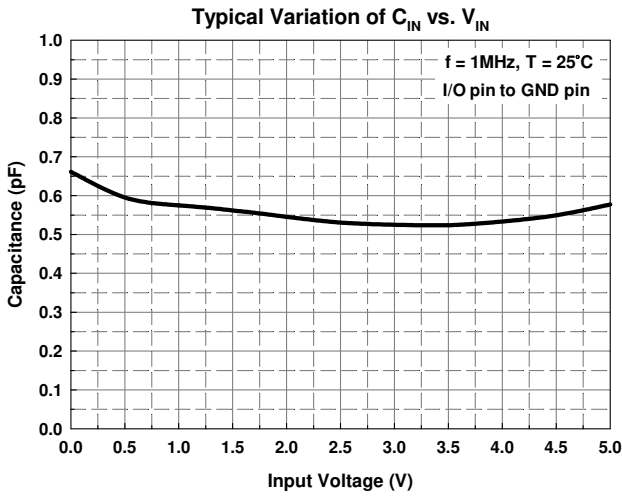

## Typical Characteristics

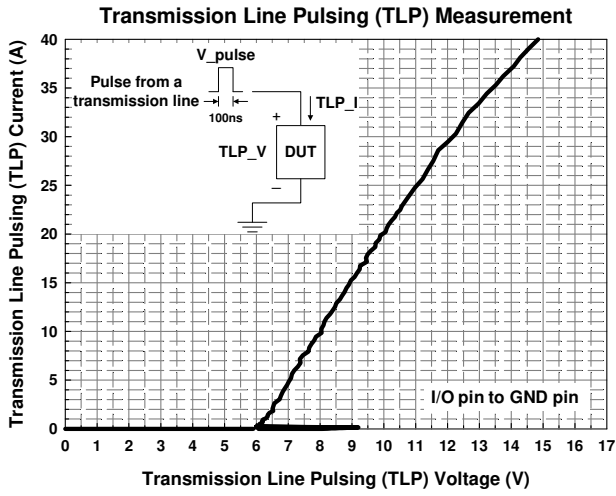

## Application Information

The AZ1145-04F is designed to protect four data lines from transient over-voltage (such as ESD stress pulse). The device connection of AZ1145-04F is shown in the Fig. 1. In Fig. 1, the four protected data lines are connected to the ESD protection pins (pin1, pin2, pin4, and pin5) of AZ1145-04F. The ground pins (pin3 and pin8) of AZ1145-04F are the negative reference pins.

These pins should be directly connected to the GND rail of PCB (Printed Circuit Board). To get minimum parasitic inductance, the path length should be kept as short as possible.

AZ1145-04F can provide ESD protection for 4 I/O signal lines simultaneously. If the number of I/O signal lines is less than 4, the unused I/O pins can be simply left as NC pins.

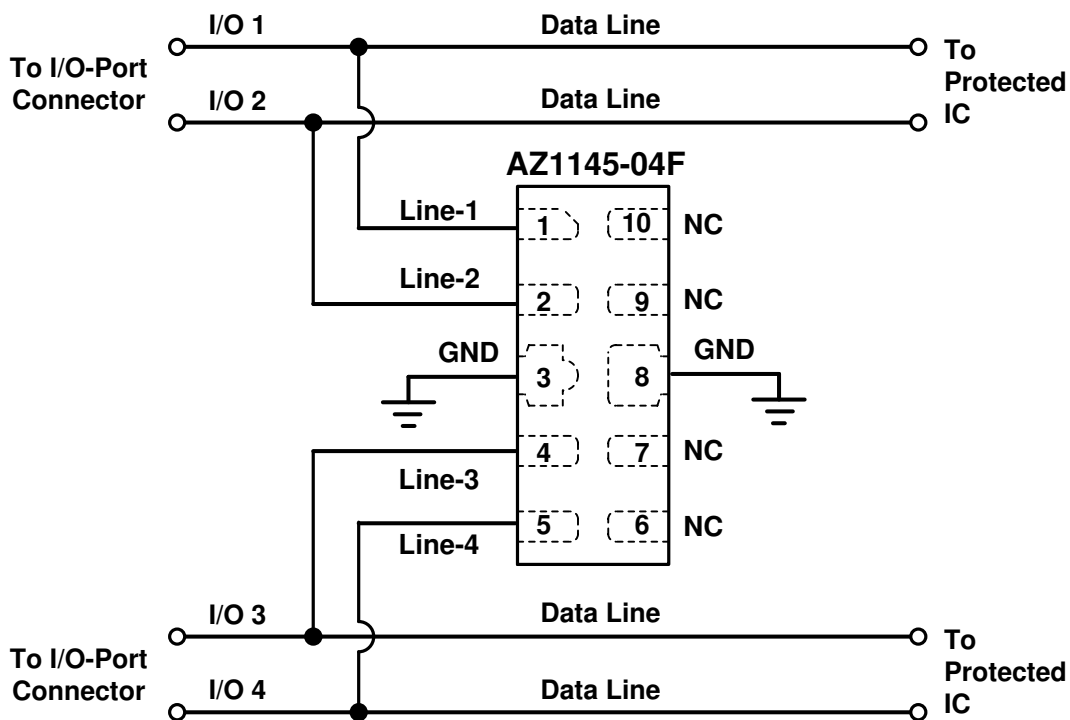

Fig. 1 Data lines connection of AZ1145-04F.

## Mechanical Details

### DFN2510P10E

#### Package Diagrams and Dimensions

TOP VIEW

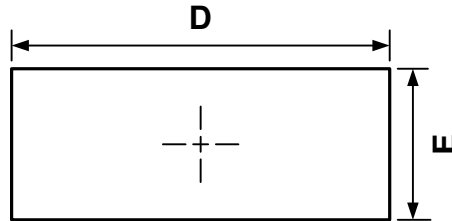

SIDE VIEW

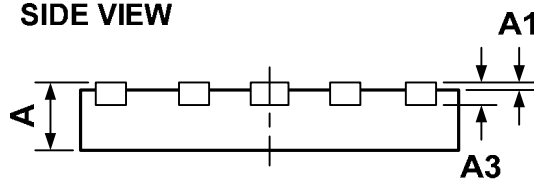

BOTTOM VIEW

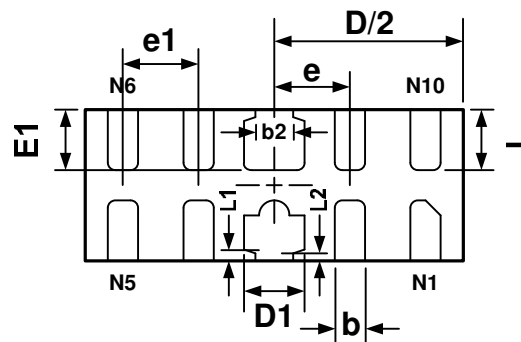

SYMBOL	MILLIMETERS	
	MIN.	MAX.
A	0.400	0.550
A1	-	0.050
A3	0.152REF	
D	2.450	2.550
E	0.950	1.050
D1	0.350	0.450
E1	0.350	0.450
b	0.150	0.250
e	0.500 BSC	
e1	0.500 BSC	
L1	0.075 REF	
L2	0.050 REF	
b2	0.200	0.300
L	0.350	0.450



## Land Layout

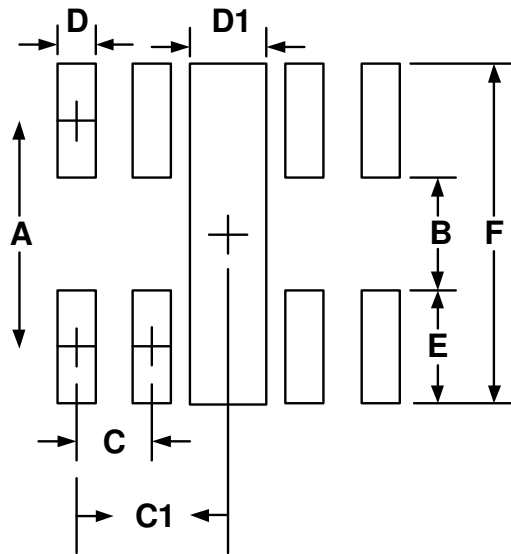

Dimensions		
Index	Millimeter	Inches
A	0.875	0.034
B	0.20	0.008
C	0.50	0.02
C1	1.00	0.039
D	0.25	0.01
D1	0.4	0.016
E	0.675	0.027
F	1.55	0.061

### Notes:

This LAND LAYOUT is for reference purposes only. Please consult your manufacturing partners to ensure your company's PCB design guidelines are met.

## Marking Code

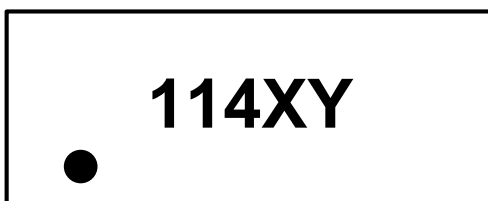

114 = Device Code  
X = Date Code  
Y = Control Code

Part Number	Marking Code
AZ1145-04F.R7G (Green Part)	114XY

Note. Green means Pb-free, RoHS, and Halogen free compliant.

## Ordering Information

PN#	Material	Type	Reel size	MOQ	MOQ/internal box	MOQ/carton
AZ1145-04F.R7G	Green	T/R	7 inch	3,000/reel	4 reels=12,000/box	6 boxes=72,000/carton



## Revision History

Revision	Modification Description
Revision 2021/12/29	Formal Release.