

RTKA227063DE0000BU

This RTKA227063DE0000BU Evaluation Board (EVB) is for testing [RAA227063](#), the Renesas 4.5V to 60V smart gate driver IC for 3-phase Brushless DC (BLDC) motor applications. This is a inverter board that works with MCU for motor driving. It can test all different design configurations of the IC.

See the RAA227063 datasheet for detail information about the signals and pins referenced in this manual, and typical waveforms using this EVB. Also see the *RAA227063 Application Overview* application note for guidelines of component selection, parameter setting, and layout.

Specifications

- Power input: 4.5V to 60V
- Gate drive voltage: default 12V, configurable from 5V to 15V
- Motor driving MOSFETs are rated at 80V 132A
- Board dimension: 5.55in × 6.31in

Figure 1 shows the system block diagram using RAA227063 EVB for motor driving and IC testing.

Features

- Configure RAA227063 to Serial Peripheral Interface (SPI) or HW Interface, and other designed configurations
- Input gate driving PWM signal either from MCU or external signal generator
- Provide interface to MCU for motor current and voltage sensing, PWM signals, fault condition, IC enabling, SPI connection, and more
- MCU connectors are compatible to Renesas MCU card such as RL78, RX13T, RX23T, RA2E1, and RA6T1
- Standard SPI communication for programming IC registers
- Provide power to MCU (default 3.3V, configurable from 1.2V to 5V)
- Support sensorless motor and motor with Hall sensors
- Six MOSFETs form the bridges for 3-phase motor driving
- Three shunt resistors for 3-phase motor current sensing

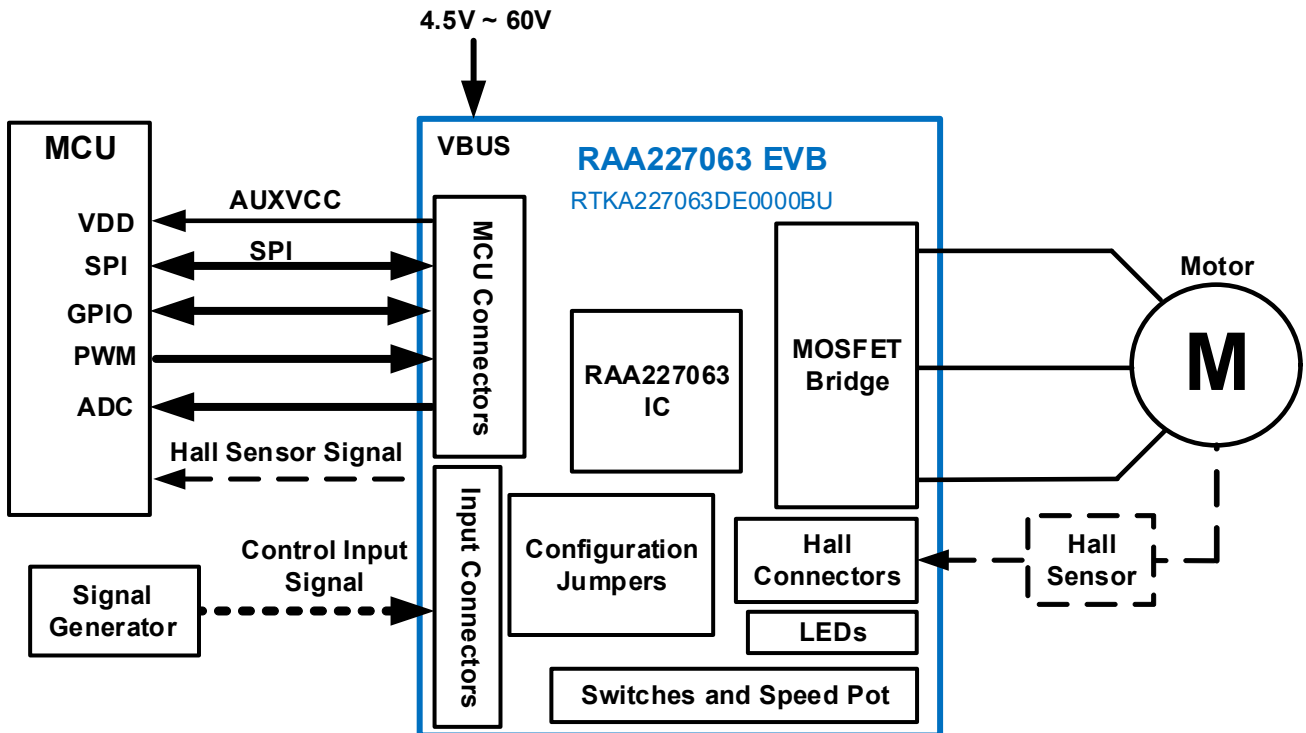

Figure 1. Block Diagram

Contents

1. Functional Description	3
1.1 Operational Characteristics	3
1.2 Setup and Configuration	4
2. Board Design	6
2.1 Schematics	6
2.2 MCU Interface	9
2.3 LED Indicators	13
2.4 Switches and Speed Potentiometer	13
2.5 Control Signal Input	13
2.6 Hall Sensor Support	13
2.7 Bill of Materials	14
2.8 Board Layout	16
3. Ordering Information	26
4. Revision History	26

1. Functional Description

The RTKA227063DE0000BU Evaluation Board (EVB) is the same test board used by Renesas engineers to evaluate the performance of the RAA227063. The board provides an easy and complete evaluation of all IC and board functions. It can work with MCU boards with appropriate firmware (FW) and a DC motor for motor driving test and demonstration, in addition to testing the IC functions without MCU/FW and motor.

Figure 2 shows the picture of the board. The board needs 4.5V to 60V power supply between VBUS and PGND terminals on top left-side of the board. It has three motor phase connectors on top, in addition to a ground terminal. The board has MCU interface connectors to communicate with MCU, jumpers and pin-straps for different IC configurations, connectors for Hall sensor signals, toggle switches and potentiometer for motor control, and LEDs to indicate board and motor running status.

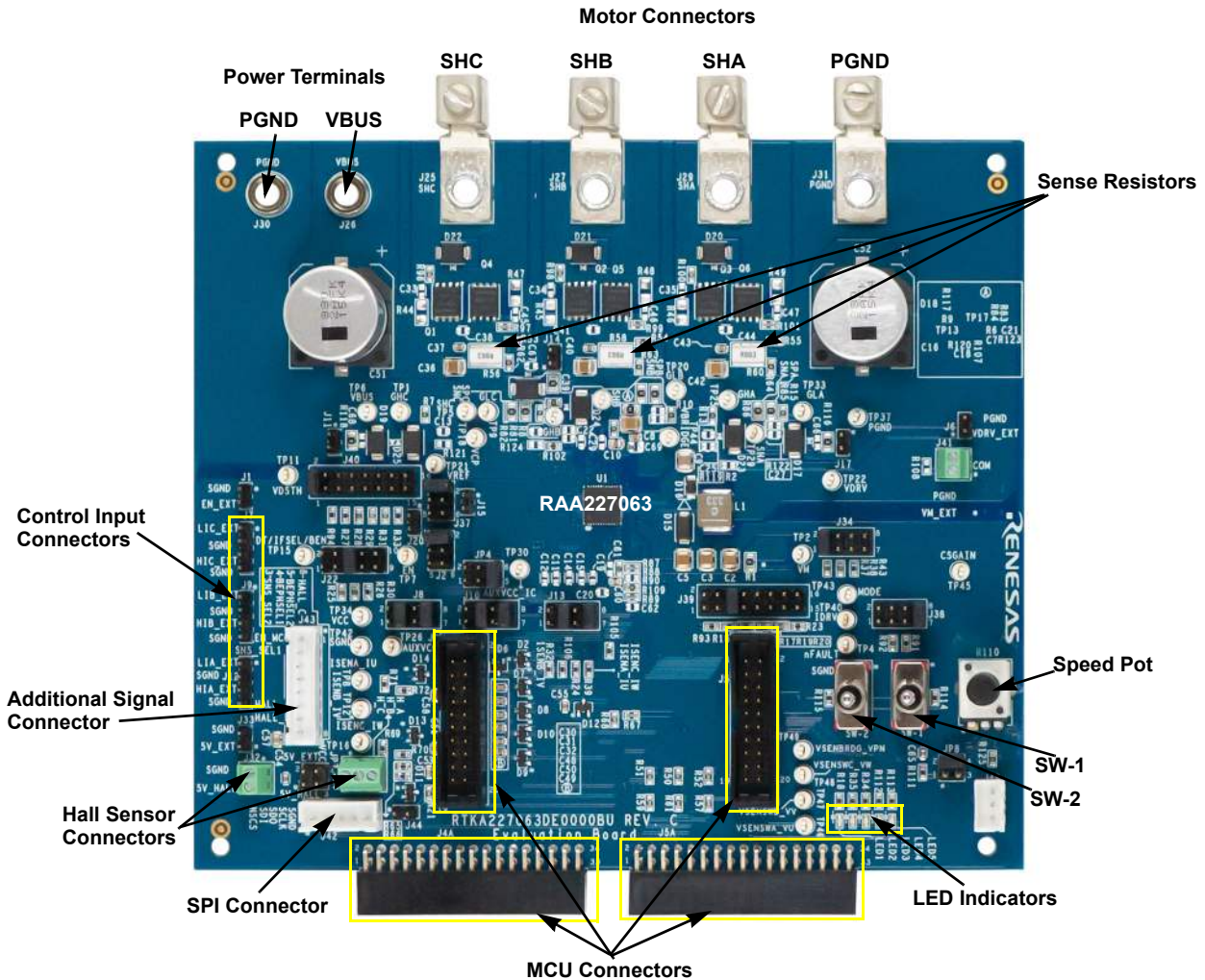

Figure 2. RTKA227063DE0000BU Evaluation Board (Top View)

1.1 Operational Characteristics

This EVB supports the full operating voltage of the RAA227063 (4.5V to 60V). Do not apply any voltage exceeding the maximum voltage rating of the IC. For motor testing, apply the motor rated voltage to the board.

The six N-channel MOSFETs (MXP80N4P7BG) installed on board are rated at 80V 132A, which works for most DC motors under 60V. Read its datasheet for more details and ensure the maximum motor driving current does not exceed the limit. **Note:** There are no heatsinks for the MOSFETs on the board, pay attention to the MOSFET temperature if running a motor at large power.

1.2 Setup and Configuration

Powering up the fresh board without any set up turns on LED2 green to indicate 5V VCC is available, which is provided by RAA227063 internal LDO from VBUS power input even before the IC is enabled. TP6 (VBUS), TP2 (VM), and TP44 (VBRIDGE) have voltages at the power input connected to VBUS. TP34 (VCC) is at 5V level. Monitor the power supply current drawing. Without motor running or gate switching, the board only consumes small amounts of current (some milliamperes).

Complete the following steps to set up the board to the required configuration. [Table 1](#) lists the main configuration jumpers. When the IC is enabled (EN pin pulls high), TP22 VDRV is at a voltage near 12V. TP18 VCP is at a voltage near VM + VDRV.

Table 1. Main Configuration Jumpers

Jumper	Signal/Pin	Description
J2	EN	IC enable options: <ul style="list-style-type: none"> Short Pin 1 and 2 to enable IC from VCC Short Pin 3 and 4 to enable IC from external input signal EN_EXT (J1) Short Pin 5 and 6 to enable IC from MCU signal EN_MCU
JP4	AUXVCC	AUXVCC options: <ul style="list-style-type: none"> Short Pin 1 and 2 to use AUXVCC from external source AUXVCC_EXT (J15) Short Pin 3 and 4 to use AUXVCC from IC (AUXVCC_IC, default 3.3V) Short Pin 5 and 6 to use AUXVCC from VCC (5V)
J22	DT/IFSEL/BEN	SPI or HW Interface option; Dead time (DT) and BEMF sensing enabling (BEN) selection for HW Interface <ul style="list-style-type: none"> Short Pin 1 and 2 to use SPI configuration (Default: DT = 150ns, BEMF sensing disabled) Short Pin 3 and 4 to use HW Interface with DT = 450ns, BEMF sensing disabled Short Pin 5 and 6 to use HW Interface with DT = 250ns, BEMF sensing disabled Short Pin 7 and 8 to use HW Interface with DT = 150ns, BEMF sensing enabled, COMMON pin as motor center tap input Short Pin 9 and 10 to use HW Interface with DT = 150ns, BEMF sensing enabled, IC internal virtual center tap as motor center tap input
J37	VREF	VREF options: <ul style="list-style-type: none"> Short Pin 1 and 2 to use AUXVCC for VREF Short Pin 3 and 4 to use external source VREF_EXT for VREF (J20) Short Pin 5 and 6 to use VCC (5V) for VREF
J8	LIC/HIC	Control input signal options (x = A, B, C): <ul style="list-style-type: none"> Short Pin 1 and 2 to use external source for Llx (J7, J9, J12) Short Pin 3 and 4 to use MCU signal for Llx Short Pin 5 and 6 to use external source for Hlx (J7, J9, J12) Short Pin 7 and 8 to use MCU signal for Hlx
J10	LIB/HIB	
J13	LIA/HIA	
J44	MODE/SDO	Short J44 to connect the SDO pull up resistor only if using SPI configuration
J11	SHC	Connecting these jumpers shorts SHx to power ground. This is for specific IC testing purpose. DO NOT connect these jumpers for normal operation
J14	SHB	
J17	SHA	
JP7	5V_HALL	Hall sensor power selection <ul style="list-style-type: none"> Short Pin 1 and 2 to use external supply 5V_EXT for Hall sensor (J33) Short Pin 3 and 4 to use 5V VCC for Hall sensor
JP8	SPEED_POT_VR	Speed potentiometer options: <ul style="list-style-type: none"> Short Pin 1 and 2 to use on-board speed potentiometer Short Pin 3 and 4 to use remote off-board speed potentiometer (not included in the EVB kit)

When AUXVCC is configured by JP4, TP26 AUXVCC should be at a voltage close to 3.3V (AUXVCC_IC option) or 5V (VCC option) after powering up the board, unless it is configured to using an external source. TP4 nFAULT should be at AUXVCC level when the IC is enabled.

The board has VDRV configured at 12V and AUXVCC at 3.3V. For different voltage applications, adjust the feedback resistor values, R88 and R89 for VDRV, R11 and R12 for AUXVCC, following the instructions provided in RAA227063 datasheet and application note.

VREF is the current-sense amplifier reference voltage input. It is divided down to 1/2 the supply actual amplifier reference voltage. Use J37 to configure the required VREF voltage as VCC or AUXVCC, and check it at TP21.

In the motor driving test, gate control input signals are from the MCU. Short Pin 3 to 4 and Pin 7 to 8 for J8/J10/J13. The IC LIx/HIx (x = A, B, C) pins connect to the PWM pin on MCU connector J5 and J4A.

For the gate switching test without an MCU/motor, control input signals can be from an external signal source. Short Pin 1 to 2 and Pin 5 to 6 for J8/J10/J13. The IC LIx/HIx pins are connected to the HIx_EXT and LIx_EXT (x = A, B, C) connectors J7, J9, and J12 on the left-side of the board.

Table 2 lists the configuration jumpers for Hardware (HW) Interface configuration. DO NOT short any pins of these pin-straps if using an SPI configuration.

Table 2. HW Interface Configuration Jumpers

Jumper	Signal/Pin	Description
J34	CSGAIN/SCLK	Current Sense (CS) amplifier gain selection <ul style="list-style-type: none"> ▪ Short Pin 1 and 2 to set CS_GAIN to 40V/V ▪ Short Pin 3 and 4 to set CS_GAIN to 20V/V ▪ Short Pin 5 and 6 to set CS_GAIN to 10V/V ▪ Short Pin 7 and 8 to set CS_GAIN to 5V/V
J38	MODE/SDO	Operation mode selection <ul style="list-style-type: none"> ▪ Short Pin 1 and 2 to set 3-phase PWM Mode and use ground-side shunt resistor for current sensing ▪ Short Pin 3 and 4 to set 3-phase PWM Mode and use low-side $r_{DS(ON)}$ for current sensing ▪ Short Pin 5 and 6 to set 3-phase HI/LI Mode and use low-side $r_{DS(ON)}$ for current sensing ▪ Short Pin 7 and 8 to set 3-phase HI/LI Mode and use ground-side shunt resistor for current sensing
J39	IDRV/SDI	Gate Driver Strength (Peak Source/Sink Current I_{src}/I_{snk}) selection <ul style="list-style-type: none"> ▪ Short Pin 1 and 2 to set $I_{src} = 1100mA$ and $I_{snk} = 2400mA$ ▪ Short Pin 3 and 4 to set $I_{src} = 700mA$ and $I_{snk} = 1400mA$ ▪ Short Pin 5 and 6 to set $I_{src} = 500mA$ and $I_{snk} = 1000mA$ ▪ Short Pin 7 and 8 to set $I_{src} = 400mA$ and $I_{snk} = 800mA$ ▪ Short Pin 9 and 10 to set $I_{src} = 310mA$ and $I_{snk} = 650mA$ ▪ Short Pin 11 and 12 to set $I_{src} = 220mA$ and $I_{snk} = 500mA$ ▪ Short Pin 13 and 14 to set $I_{src} = 160mA$ and $I_{snk} = 350mA$ ▪ Short Pin 15 and 16 to set $I_{src} = 70mA$ and $I_{snk} = 180mA$
J40	VDSTH/nSCS	VDS OCP Threshold (VDS_TH) selection <ul style="list-style-type: none"> ▪ Short Pin 1 and 2 to set VDS_TH = 2150mV ▪ Short Pin 3 and 4 to set VDS_TH = 1600mV ▪ Short Pin 5 and 6 to set VDS_TH = 1200mV ▪ Short Pin 7 and 8 to set VDS_TH = 710mV ▪ Short Pin 9 and 10 to set VDS_TH = 645mV ▪ Short Pin 11 and 12 to set VDS_TH = 400mV ▪ Short Pin 13 and 14 to set VDS_TH = 240mV ▪ Short Pin 15 and 16 to set VDS_TH = 75mV

2. Board Design

Figure 2 shows the top image of the board. The RAA227063 IC is at the center of the board; the motor connectors are on top; the MCU connectors are on lower/bottom of the board; and the external control input signals for gate control are on left for testing the IC without MCU and motor. There is a SPI connector J42 on the bottom left for convenience. The motor control switches SW-1/SW-2 and speed potentiometer are on the bottom right. Main configuration jumpers are located in the middle of the board. Figure 3 shows the bottom image of the board.

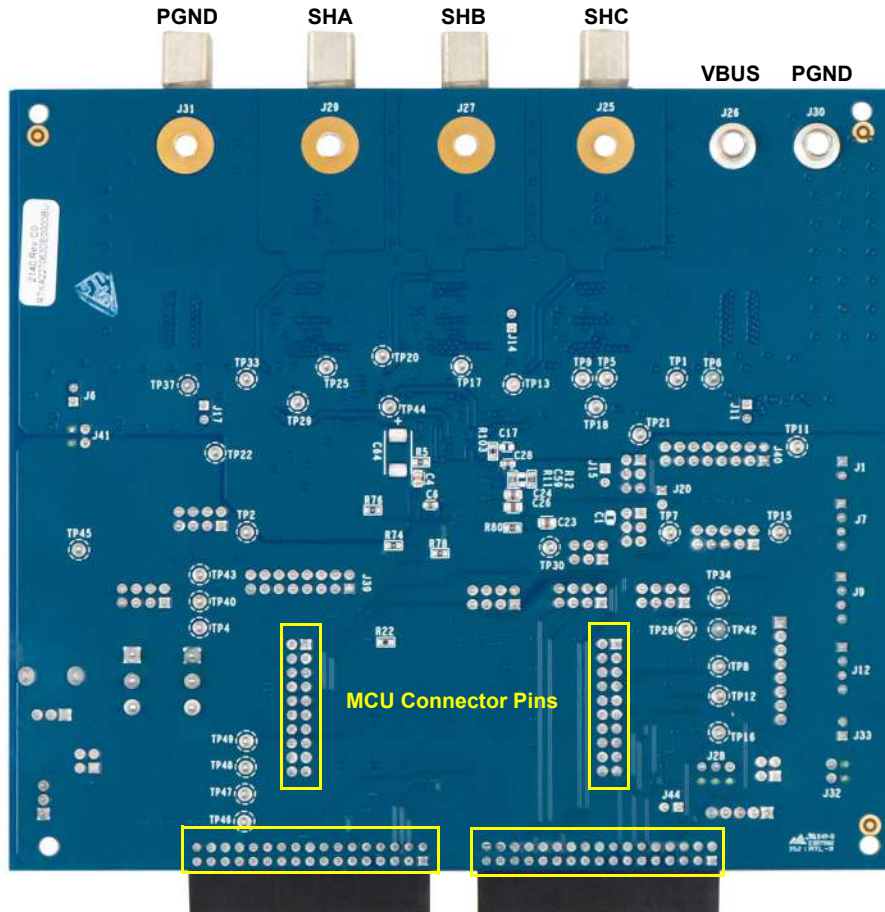

Figure 3. RTKA227063DE0000BU Evaluation Board (Bottom View)

2.1 Schematics

Figure 4 and Figure 5 show the total two pages of the board schematic. The schematic file can be downloaded from Renesas website. The first page includes the RAA227063 and its external components, MCU connectors, configuration jumpers, SPI connector, and test points. The second page includes the main power input, 3-phase drive bridges, motor voltage sensing, Hall sensor support, extra MCU connectors, toggle switches, speed potentiometer, and motor connection terminals.

DNP (Do Not Populate) components are not installed on the board. They are place holders for possible usage in certain applications when necessary, such as the MOSFET snubber and extra filtering capacitors.

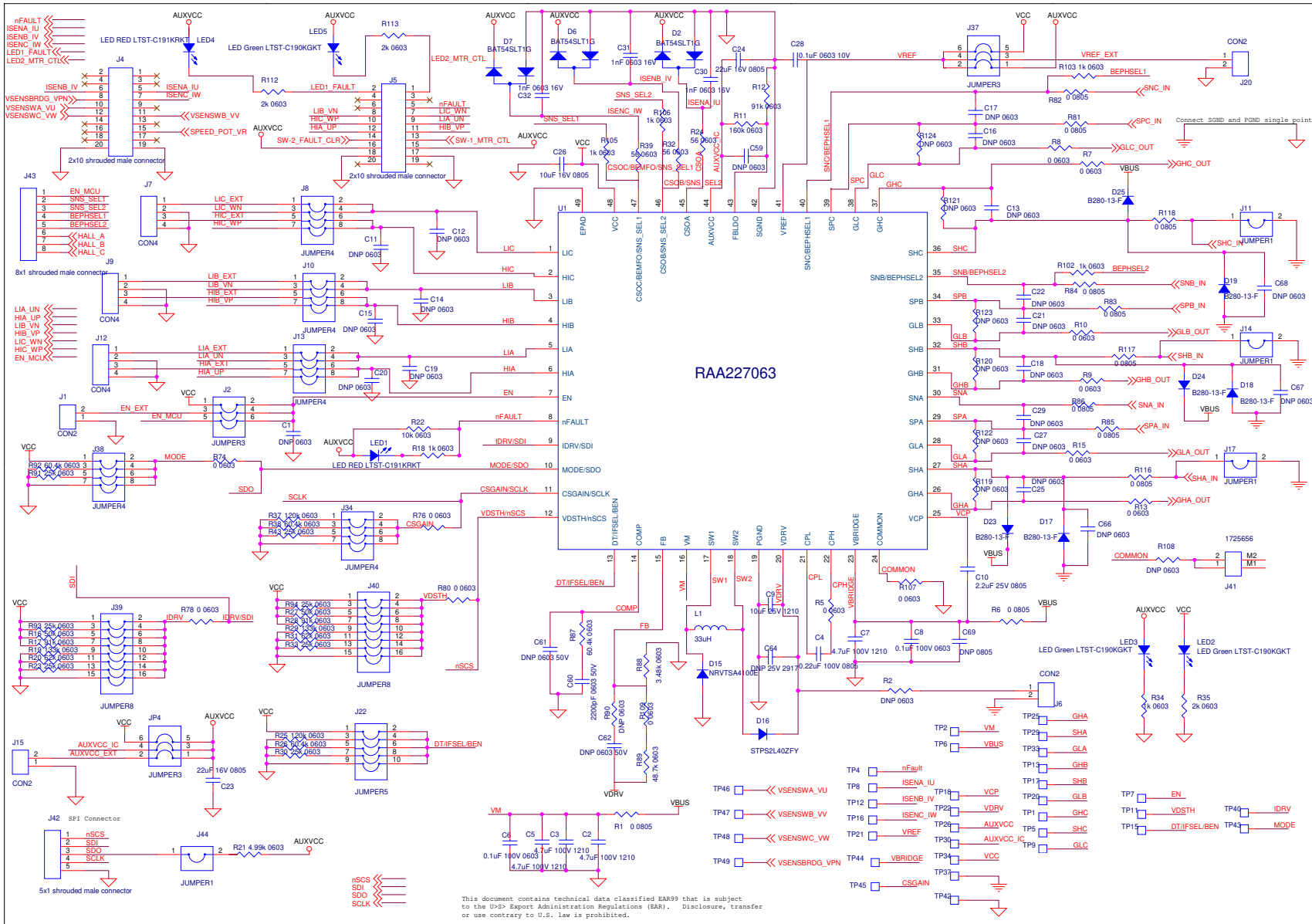

Figure 4. RTKA227063DE0000BU Evaluation Board Schematic (Page 1)

2.2 MCU Interface

The board has MCU connectors J4 and J5 that are compatible to Renesas RL78, RX13T, RX23T, RX24T, and RA6T1 MPU card connectors CNA and CNB. [Table 3](#) lists the pin assignments for the MCU connector J4 and [Table 4](#) list the pin assignments for the MCU J5. See the schematic in [Figure 4](#). The MCU card information can be found on the [website](#).

Table 3. MCU Connector J4 Pin Assignments

Pin	Name	Description
1	N/C	Not connected
2	N/C	Not connected
3	N/C	Not connected
4	N/C	Not connected
5	ISENSA_IU	Motor current sense signal for Phase A (U)
6	ISENSB_IV	Motor current sense signal for Phase B (V)
7	ISENSC_IW	Motor current sense signal for Phase C (W)
8	VSENSBRDG_VPN	Motor voltage sense signal for VBRIDGE
9	N/C	Not connected
10	VSENSWA_VU	Motor voltage sense signal for Phase A (U)
11	VSENSWB_VV	Motor voltage sense signal for Phase B (V)
12	VSENSWC_VW	Motor voltage sense signal for Phase C (W)
13	N/C	Not connected
14	N/C	Not connected
15	SPEED_POT_VR	Motor speed adjust potentiometer signal
16	N/C	Not connected
17	N/C	Not connected
18	N/C	Not connected
19	SGND	Signal ground
20	SGND	Signal ground

Table 4. MCU Connector J5 Pin Assignments

Pin	Name	Description
1	LED2_MTR_CTL	LED signal from MCU to indicate motor status to LED5 (green) on board
2	LED1_FAULT	LED signal from MCU to indicate system fault to LED4 (red) on board
3	N/C	Not connected
4	N/C	Not connected
5	nFAULT	RAA227063 IC fault signal to MCU
6	N/C	Not connected
7	LIC_WN	Gate control input signal for low side FET of Phase C (W)
8	LIB_VN	Gate control input signal for low side FET of Phase B (V)
9	LIA_UN	Gate control input signal for low side FET of Phase A (U)
10	HIC_WP	Gate control input signal for high side FET of Phase C (W)

Table 4. MCU Connector J5 Pin Assignments (Cont.)

Pin	Name	Description
11	HIB_VP	Gate control input signal for high side FET of Phase B (V)
12	HIA_UP	Gate control input signal for high side FET of Phase A (U)
13	SW-1_MTR_CTL	Switch1 (SW-1) signal to MCU
14	SW-2_FAULT_CLR	Switch2 (SW-2) signal to MCU
15	AUXVCC	Supply voltage from RAA227063 to MCU
16	AUXVCC	Supply voltage from RAA227063 to MCU
17	SGND	Signal ground
18	SGND	Signal ground
19	N/C	Not connected
20	N/C	Not connected

The EVB also has MCU connectors (J4A and J5A) that are compatible to the new Renesas RA2E1 MCU board. [Table 5](#) and [Table 6](#) list the pin assignments for the MCU connector J4A and J5A. See the schematic in [Figure 5](#).

For some communication signals to MCU that are not covered in the MCU connectors J4, J5, J4A, and J5A, the EVB provides an additional signal connector, J43, and SPI connector, J42. See [Table 7](#) and [Table 8](#) and schematic for the pin assignments.

Table 5. MCU Connector J4A Pin Assignments

Pin	Name	Description
1	N/C	Not connected
2	SGND	Signal ground
3	VSENSBRDG_VPN	Motor voltage sense signal for VBRIDGE
4	SGND	Signal ground
5	ISENA_IU	Motor current sense signal for Phase A (U)
6	SGND	Signal ground
7	ISENB_IV	Motor current sense signal for Phase B (V)
8	SGND	Signal ground
9	ISENC_IW	Motor current sense signal for Phase C (W)
10	SGND	Signal ground
11	VSENSWA_VU	Motor voltage sense signal for Phase A (U)
12	VSENSWB_VV	Motor voltage sense signal for Phase B (V)
13	VSENSWC_VW	Motor voltage sense signal for Phase C (W)
14	SGND	Signal ground
15	N/C	Not connected
16	N/C	Not connected
17	N/C	Not connected
18	SGND	Signal ground
19	N/C	Not connected
20	SGND	Not connected

Table 5. MCU Connector J4A Pin Assignments (Cont.)

Pin	Name	Description
21	N/C	Not connected
22	SGND	Signal ground
23	LIA_UN	Gate control input signal for low side FET of Phase A (U)
24	SGND	Signal ground
25	HIA_UP	Gate control input signal for high side FET of Phase A (U)
26	SGND	Signal ground
27	LIB_VN	Gate control input signal for low side FET of Phase B (V)
28	SGND	Signal ground
29	HIB_VP	Gate control input signal for high side FET of Phase B (V)
30	SGND	Signal ground
31	LIC_WN	Gate control input signal for low side FET of Phase C (W)
32	SGND	Signal ground
33	HIC_WP	Gate control input signal for high side FET of Phase C (W)
34	SGND	Signal ground

Table 6. MCU Connector J5A Pin Assignment

Pin	Name	Description
1	AUXVCC	Supply voltage from RAA227063 to MCU
2	N/C	Not connected
3	SCLK	SPI clock input from MCU
4	SDI	SPI data input from MCU (MOSI)
5	SDO	SPI data output to MCU (MISO)
6	nSCS	SPI chip select from MCU
7	EN_MCU	IC enable from MCU
8	nFAULT	IC nFAULT to MCU
9	N/C	Not connected
10	HALL_A	Hall sensor signal to MCU (Phase A)
11	HALL_B	Hall sensor signal to MCU (Phase B)
12	HALL_C	Hall sensor signal to MCU (Phase C)
13	N/C	Not connected
14	N/C	Not connected
15	N/C	Not connected
16	N/C	Not connected
17	N/C	Not connected
18	SGND	Signal ground
19	N/C	Not connected
20	N/C	Not connected

Table 6. MCU Connector J5A Pin Assignment (Cont.)

Pin	Name	Description
21	N/C	Not connected
22	N/C	Not connected
23	N/C	Not connected
24	N/C	Not connected
25	N/C	Not connected
26	N/C	Not connected
27	N/C	Not connected
28	SGND	Signal ground
29	N/C	Not connected
30	SGND	Signal ground
31	N/C	Not connected
32	SGND	Signal ground
33	N/C	Not connected
34	N/C	Not connected

Table 7. Additional Signal Connector J43 Pin Assignment

Pin	Name	Description
1	EN_MCU	IC enable from MCU
2	SNS_SEL1	Control signal 1 input from MCU for Sample/Hold output selection of current sense amplifier (CSA, CSB, CSC)
3	SNS_SEL2	Control signal 2 input from MCU for Sample/Hold output selection of current sense amplifier (CSA, CSB, CSC)
4	BEPHSEL1	Control signal 1 input from MCU for BEMF sensing phase selection
5	BEPHSEL2	Control signal 2 input from MCU for BEMF sensing phase selection
6	HALL_A	Hall sensor signal to MCU (Phase A)
7	HALL_B	Hall sensor signal to MCU (Phase B)
8	HALL_C	Hall sensor signal to MCU (Phase C)

Table 8. SPI Connector J42 Pin Assignments

Pin	Name	Description
1	nSCS	SPI chip select from MCU
2	SDI	SPI data input from MCU (MOSI)
3	SDO	SPI data output to MCU (MISO)
4	SCLK	SPI clock input from MCU
5	SGND	Signal ground

2.3 LED Indicators

The board has five LEDs located at lower right corner for system status indication. [Table 9](#) describes the LEDs.

Note: LED4 and LED5 functions need appropriate firmware to support.

Table 9. LED Indicators

LED	Name	Description
1	nFAULT	Red: Turns on when the IC nFAULT pulls low
2	VCC	Green: Turns on when VCC (5V) is ON
3	AUXVCC	Green: Turns on when AUXVCC is ON
4	FAULT	Red: Turns on when MCU declares system fault, or depends on firmware programming. Control signal is input from the MCU through J5 Pin 2.
5	Motor Status	Green: Turns on when MCU declares motor running, or depends on firmware programming. Control signal is input from the MCU through J5 Pin 1.

2.4 Switches and Speed Potentiometer

The board has two toggle switches (SW-1 and SW-2) and one potentiometer (Speed Pot R110) located at lower right corner.

SW-1 controls the motor start/stop or change direction with appropriate firmware support. Toggle down to close the switch and bring SW-1_MTR_CTL signal from AUXVCC to ground.

SW-2 clears the MCU fault with appropriate firmware support. Toggle down to close the switch and bring SW-2_FAULT_CLR signal from AUXVCC to ground.

You can assign different functions for the toggles switches on the board with firmware support.

Speed Pot adjusts motor speed and direction with appropriate firmware support. Turning from CCW to CW positions increases SPEED_POT_VR voltage from 0 to AUXVCC. It has a center detent that can make the voltage to half of AUXVCC. The firmware can be designed to use the center detent voltage to spin the motor in different direction.

There is also a connector (J45) that allows a remote potentiometer connection if required. Configure JP8 for using on-board or remote potentiometer as indicated in [Table 1](#). The external potentiometer is not provided with the EVB board.

2.5 Control Signal Input

When the EVB receives gate control PWM signals from the MCU, the signals are input through the MCU connector J5 or J4A. When the EVB is tested without the MCU, the gate control signals are input through Llx_EXT and Hlx_EXT (x = A, B, C) connectors J7, J9, J12 located at left-side of the board. Configure jumpers J8, J10, and J13 accordingly based on [Table 1](#).

2.6 Hall Sensor Support

For a motor with a Hall sensor, connect J32 5V_HALL to the Hall sensor power, and sensor signals to J28 connector. Connect the conditioned Hall sensor signals (HALL_A, HALL_B, HALL_C) to the MCU through the MCU connector J5A, or the additional signal connector J43.

2.7 Bill of Materials

Qty	Reference Designator	Description	Manufacturer	Manufacturer Part Number
0	C1, C11, C12, C13, C14, C15, C16, C17, C18, C19, C20, C21, C22, C25, C27, C29, C33, C34, C35, C38, C41, C44, C45, C46, C47, C59, C66, C67, C68	DNP 0603		
7	C2, C3, C5, C7, C36, C39, C42	4.7 μ F 100V 1210	TDK	C3225X7S2A475K200AB
1	C4	0.22 μ F 100V 0805	Kemet	C0805C224K1RACAUTO
9	C6, C8, C37, C40, C43, C48, C49, C50, C55	0.1 μ F 100V 0603	Venkel	C0603X7R101-104KNE
1	C9	10 μ F 25V 1210	AVX	12103C106KAT2A
1	C10	2.2 μ F 25V 0805	AVX	08053C225KAT2A
2	C23, C24	22 μ F 16V 0805	Venkel	C0805X5R160-226KNE
1	C26	10 μ F 16V 0805	Venkel	C0805X5R160-106KNE
1	C28	0.1 μ F 0603 10V	Kemet	C0603C104K8RACTU
3	C30, C31, C32	1nF 0603 16V	Venkel	C0603X7R160102KNE
2	C51, C52	330 μ F 100V	Panasonic	EEV-FK2A331M
3	C53, C56, C58	1nF 0603 50V	AVX	06035C102KAT2A
1	C54	100nF 0603 50V	AVX	06035C104KAT2A
1	C57	4.7 μ F 16V 0805	Murata	GCJ21BR71C475KA01L
1	C60	2200pF 0603 50V	Samsung	CL10B222KB8NNNC
0	C61, C62	DNP 0603 50V		
0	C64	DNP 25V 2917		
1	C65	0.1 μ F 25V 0603	Yageo	CC0603KRX7R8BB104
0	C69	DNP 0805		
6	D2, D6, D7, D11, D13, D14	Diode Array Schottky 30V	Onsemi	BAT54SLT1G
4	D8, D9, D10, D12	Diode Array 100V	Onsemi	BAV99LT1G
1	D15	Diode Schottky 100V	Onsemi	NRV TSA4100ET3G
9	D17, D18, D19, D20, D21, D22, D23, D24, D25	Diode Schottky 80V	Diodes	B280-13-F
9	J1, J6, J11, J14, J15, J17, J20, J33, J44	CONN-HEADER, TH, 1 \times 2	Würth	61300211121
3	J2, J37, JP4	CONN-HEADER, TH, 2 \times 3	Würth	61300621121
2	J4, J5	2 \times 10 shrouded male connector	Molex	70246-2001
2	J4A, J5A	CONNECTOR, RCPT, 34POS, 2ROW, 2.54MM	Würth	613034243121
3	J7, J9, J12	CONN-HEADER, TH, 1 \times 4	Würth	61300411121
5	J8, J10, J13, J34, J38	CONN-HEADER, TH, 2 \times 4	Würth	61300821121
1	J22	CONN-HEADER, TH, 2 \times 5	Würth	61301021121
4	J25, J27, J29, J31	Lug Terminals	BERG/FCI	KPA8CTP

Qty	Reference Designator	Description	Manufacturer	Manufacturer Part Number
2	J26, J30	Banana Jack	Keystone	575-4
1	J28	Fixed Terminal Blocks 3P 2.54mm 90DEG	Phoenix Contact	1725669
2	J32, J41	Fixed Terminal Blocks 2P 2.54mm 90DEG	Phoenix Contact	1725656
2	J39, J40	CONN-HEADER, TH, 2×8	Wurth	61301621121
1	J42	5×1 shrouded male connector	JST	B5B-XH-A(LF)(SN)
1	J43	8×1 shrouded male connector	JST	B8B-XH-A(LF)(SN)
1	J45	3×1 shrouded male connector	JST	B3B-XH-A(LF)(SN)
2	JP7, JP8	JUMPER2	Wurth	61300421121
1	L1	Inductor 33μH	Coilcraft	XAL6060-333MEB
2	LED1, LED4	LED RED	Liteon	LTST-C191KRKT
3	LED2, LED3, LED5	LED GREEN	Liteon	LTST-C190KGKT
6	Q1, Q2, Q3, Q4, Q5, Q6	N-Channel MOSFET	Maxpower	MXP80N4P7BG
11	R1, R6, R81, R82, R83, R84, R85, R86, R116, R117, R118	0Ω 0805	Yageo	RC0805JR-070RL
0	R2, R90, R108, R119, R120, R121, R122, R123, R124	DNP 0603		
20	R5, R7, R8, R9, R10, R13, R15, R53, R54, R55, R62, R63, R64, R74, R76, R78, R80, R107, R109, R125	0Ω 0603	Venkel	CR0603-10W-000T
1	R11	160k 0603	Yageo	RC0603FR-07160KL
3	R12, R17, R28	91k 0603	Panasonic	ERJ-3EKF9102V
2	R16, R27	50k 0603	Venkel	CR0603-10W-4992FT
7	R18, R21, R34, R102, R103, R105, R106	1k 0603	Panasonic	ERJ-3EKF1001V
2	R19, R29	133k 0603	Venkel	CR0603-10W-1333FT
2	R20, R31	62k 0603	Yageo	RC0603FR-0762KL
7	R22, R65, R66, R69, R70, R71, R72	10k 0603	Venkel	CR0603-10W-1002FT
7	R23, R30, R33, R43, R91, R93, R94	24.9k 0603	Panasonic	ERJ-3EKF2492V
3	R24, R32, R39	56 0603	Panasonic	ERJ-3EKF56R0V
2	R25, R37	120k 0603	Vishay/Dale	CRCW0603120KFKEA
4	R26, R38, R87, R92	60.4k 0603	Yageo	RC0603FR-0760K4L
6	R35, R111, R112, R113, R114, R115	2k 0603	KOA	RK73H1JTDD2001F
0	R44, R45, R46, R47, R48, R49	DNP 1206		
10	R50, R51, R52, R67, R96, R97, R98, R99, R100, R101	100k 0603	Venkel	CR0603-10W-1003FT
3	R56, R58, R60	3m 2512 3W sense resistor	Susumu	KRL6432E-M-R003-F-T1
4	R57, R59, R61, R68	4.99k 0603	Panasonic	ERJ-3EKF4991V
1	R88	3.48k 0603	Panasonic	ERJ-3EKF3481V

Qty	Reference Designator	Description	Manufacturer	Manufacturer Part Number
1	R89	48.7k 0603	Panasonic	ERJ-3EKF4872V
1	R110	10k Speed Pot	Bourns	PTV09A-4225U-B103
2	SW-1, SW-2	Toggle switch	E-switch	100SP3T1B1M2QE
34	TP1, TP2, TP4, TP5, TP6, TP7, TP8, TP9, TP11, TP12, TP13, TP15, TP16, TP17, TP18, TP20, TP21, TP22, TP25, TP26, TP29, TP30, TP33, TP34, TP37, TP40, TP42, TP43, TP44, TP45, TP46, TP47, TP48, TP49	TEST POINT	Keystone	5007
1	U1	IC-3-PHASE 60V MOTOR DRIVER, 48P, QFN, ROHS	Renesas	RAA2270634GNP#AA0

2.8 Board Layout

Figure 6 to Figure 15 show the board layout of each layer. Board design file can also be downloaded from Renesas web site.

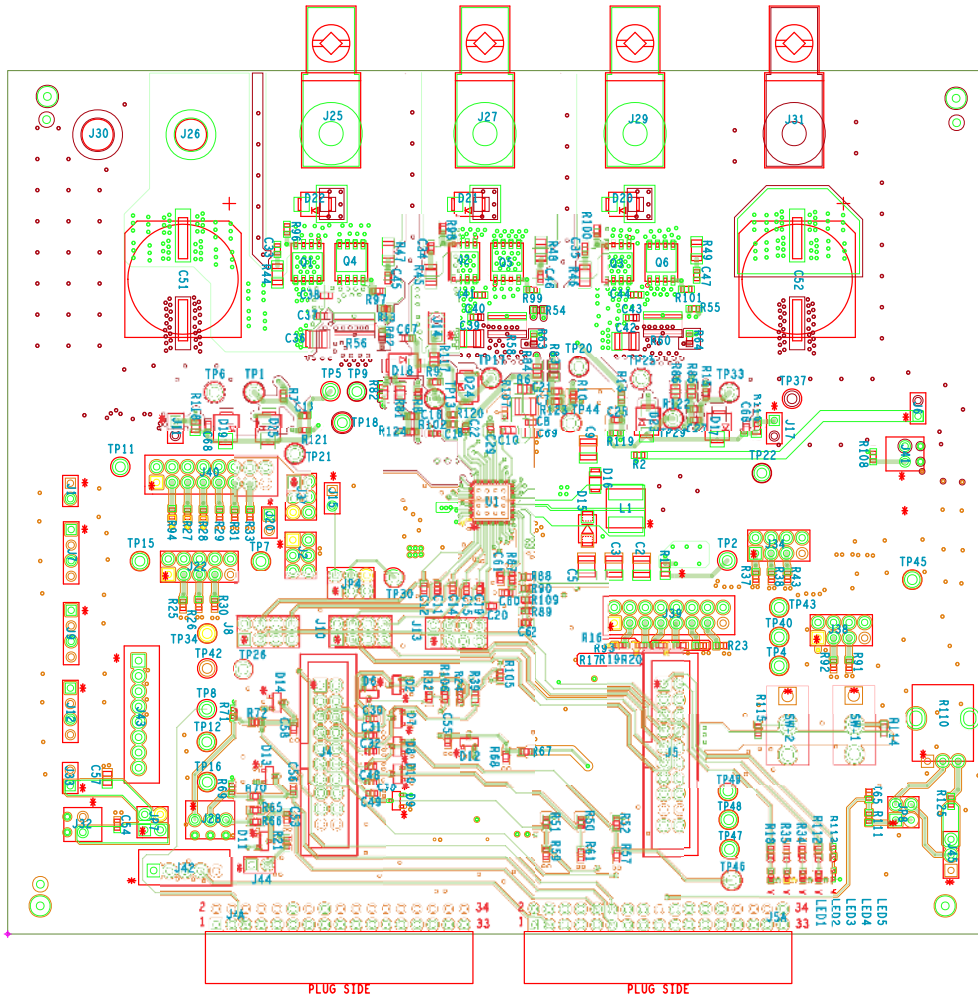

Figure 6. Evaluation Board Layer 1 (Top Layer)

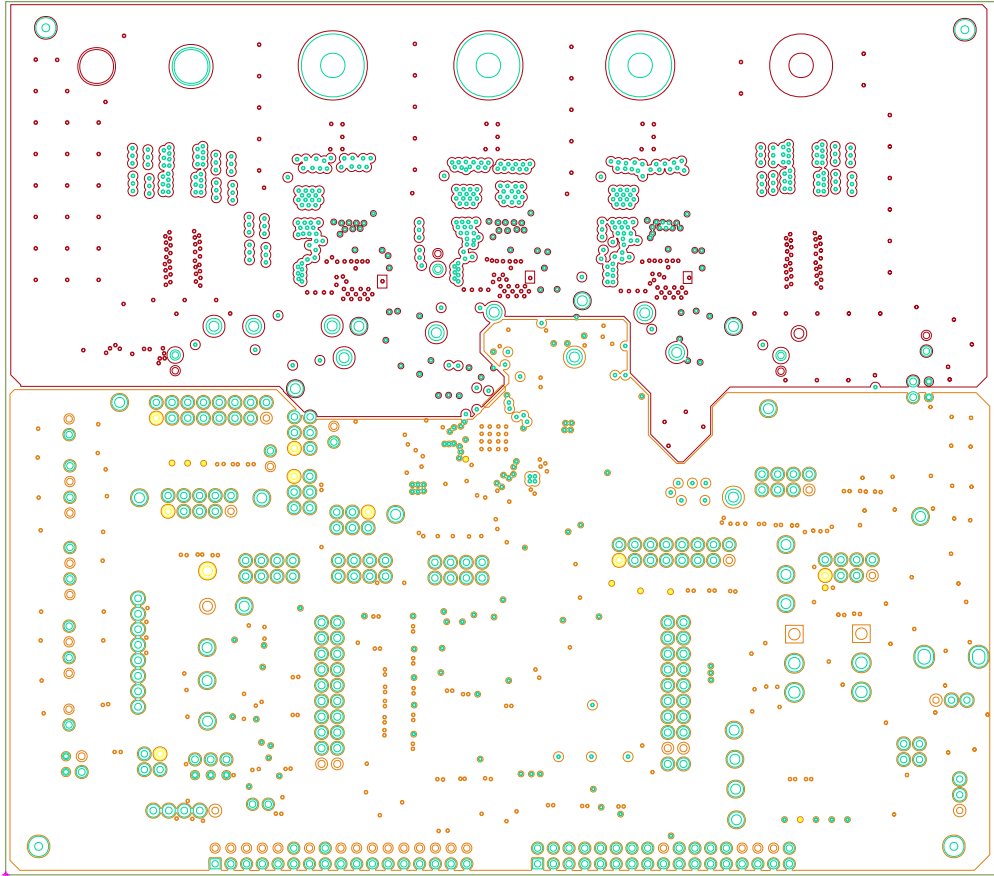

Figure 7. Evaluation Board Layer 2

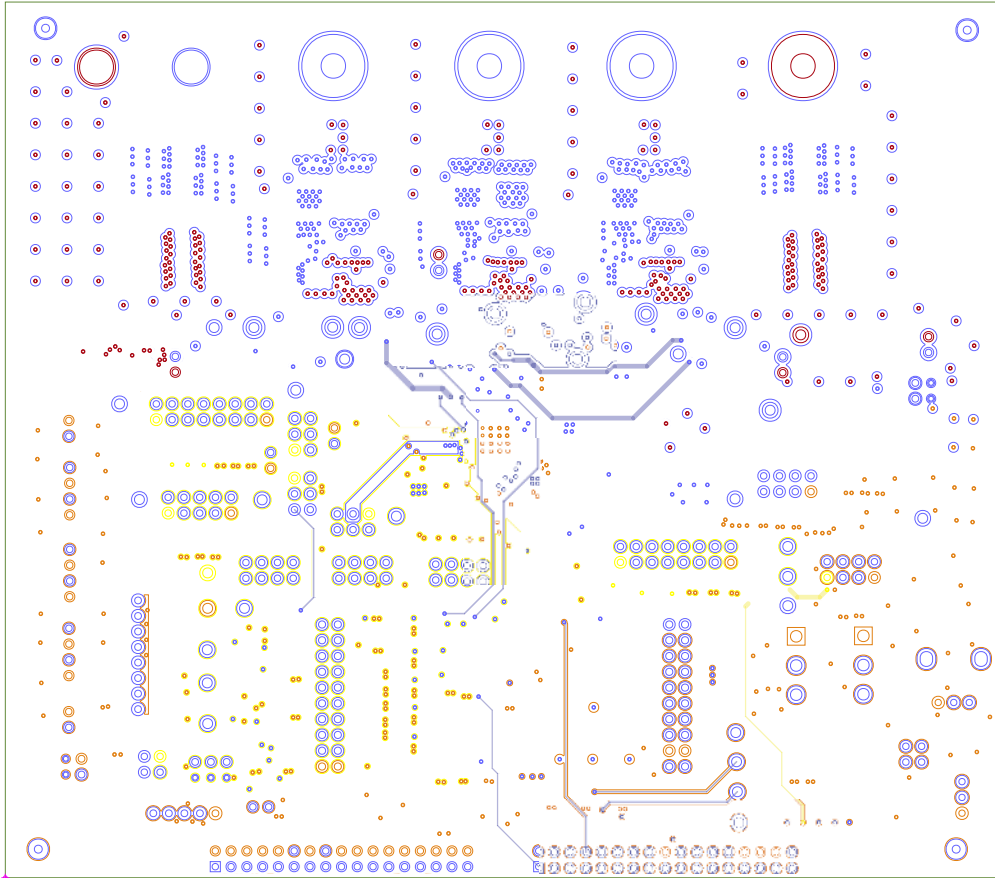

Figure 8. Evaluation Board Layer 3

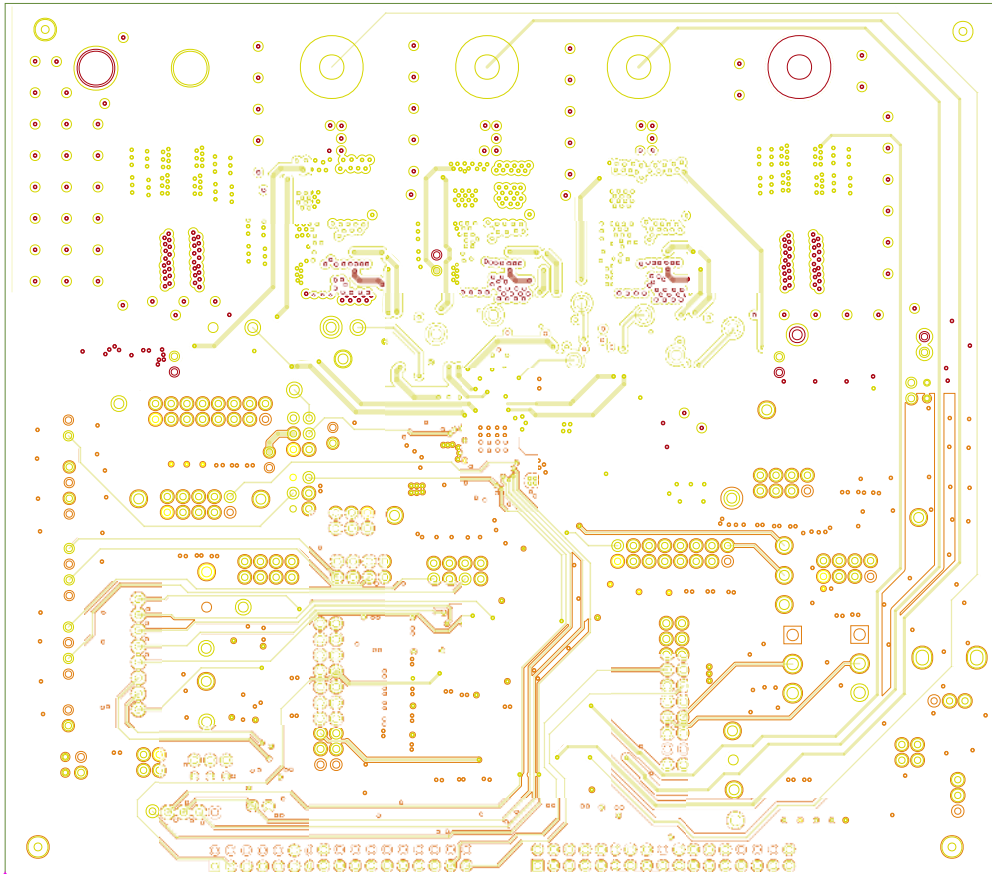

Figure 9. Evaluation Board Layer 4

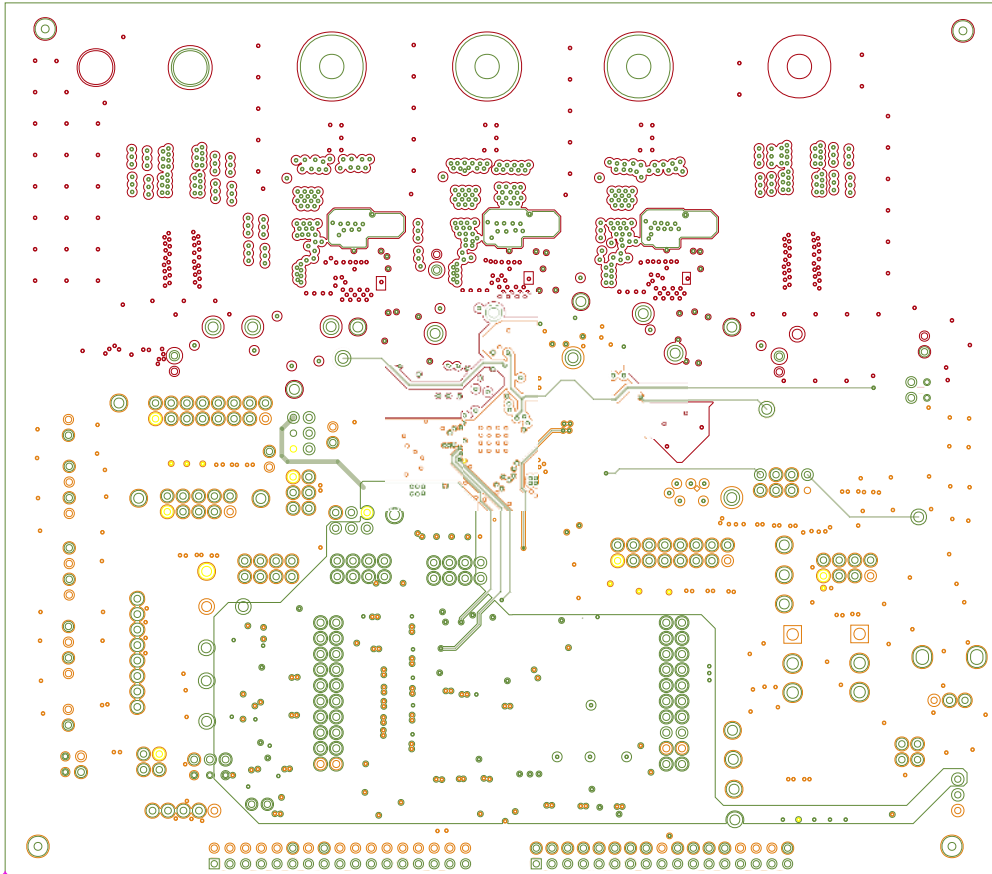

Figure 10. Evaluation Board Layer 5

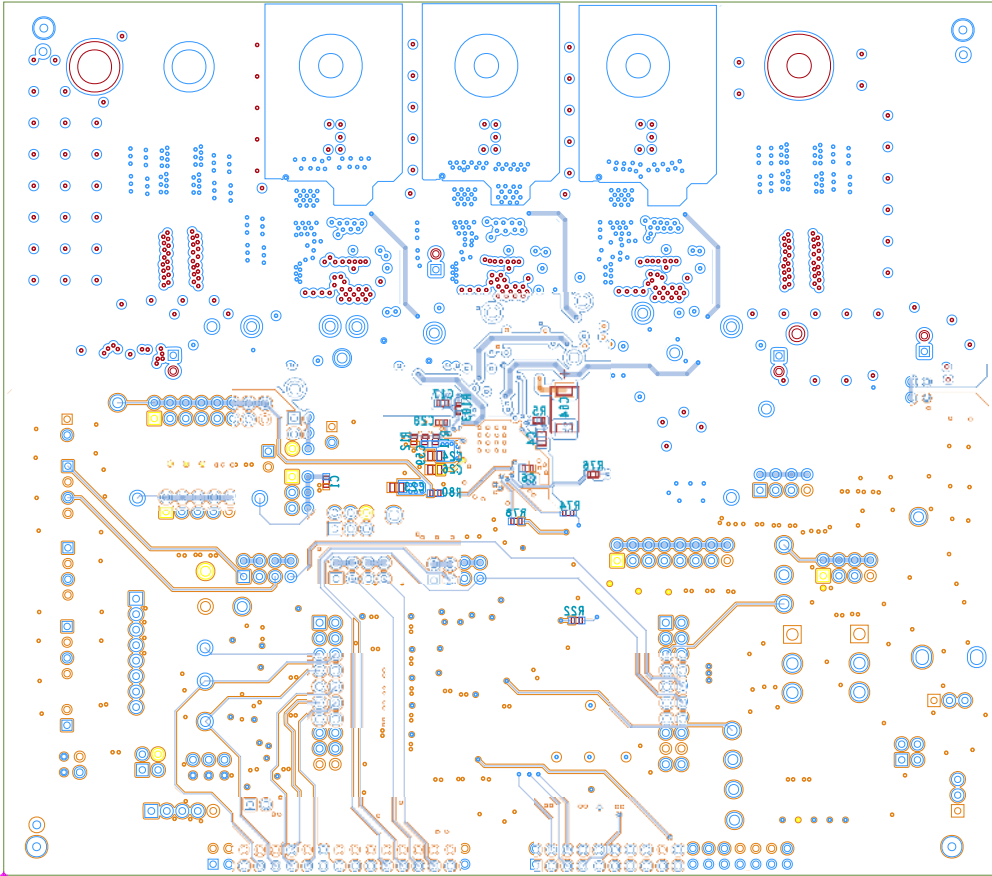

Figure 11. Evaluation Board Layer 6 (Bottom Layer)

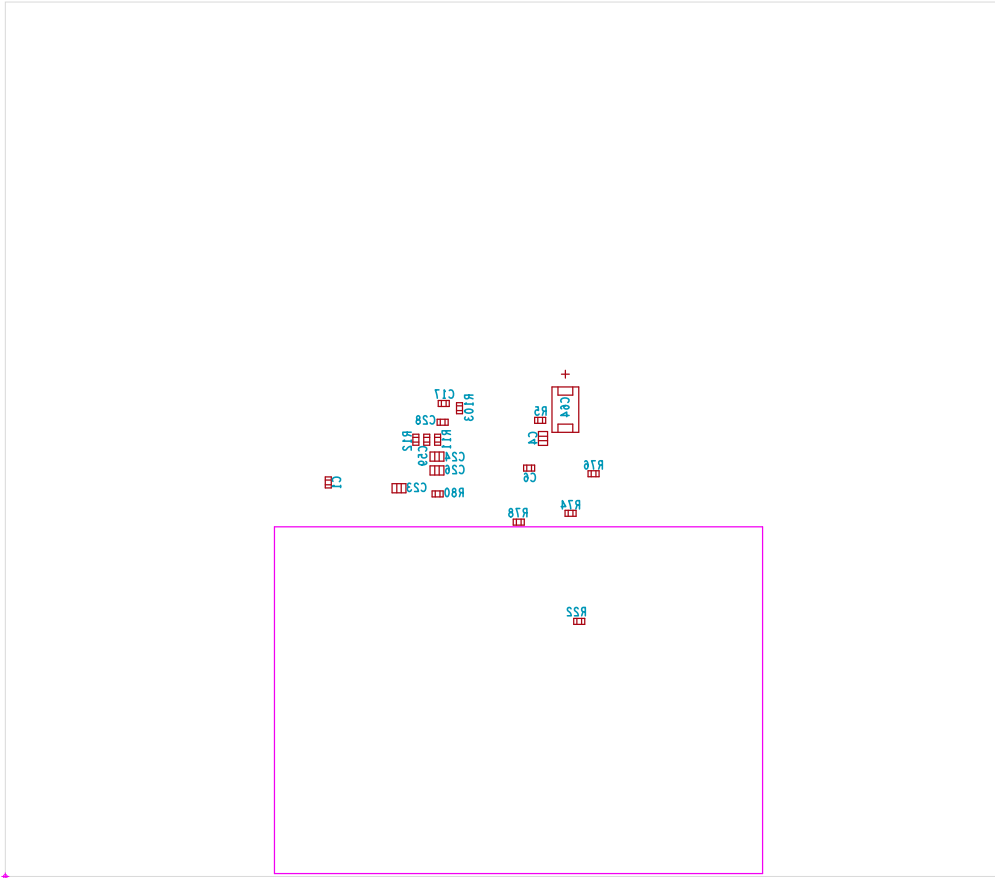

Figure 13. Evaluation Board Assembly Bottom

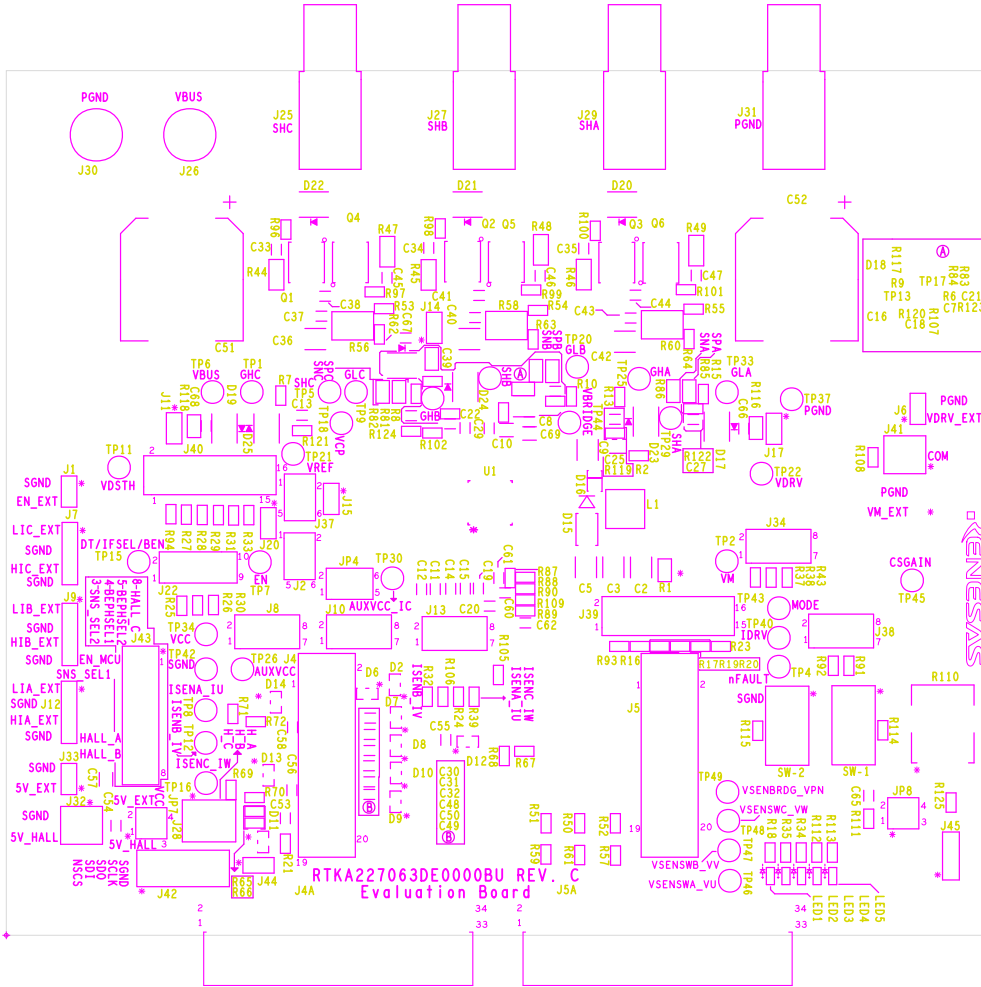

Figure 14. Evaluation Board Silkscreen Top

3. Ordering Information

Part Number	Description
RTKA227063DE0000BU	RAA227063 Evaluation Board

4. Revision History

Revision	Date	Description
1.00	Nov 1, 2021	Initial release

IMPORTANT NOTICE AND DISCLAIMER

RENESAS ELECTRONICS CORPORATION AND ITS SUBSIDIARIES (“RENESAS”) PROVIDES TECHNICAL SPECIFICATIONS AND RELIABILITY DATA (INCLUDING DATASHEETS), DESIGN RESOURCES (INCLUDING REFERENCE DESIGNS), APPLICATION OR OTHER DESIGN ADVICE, WEB TOOLS, SAFETY INFORMATION, AND OTHER RESOURCES “AS IS” AND WITH ALL FAULTS, AND DISCLAIMS ALL WARRANTIES, EXPRESS OR IMPLIED, INCLUDING, WITHOUT LIMITATION, ANY IMPLIED WARRANTIES OF MERCHANTABILITY, FITNESS FOR A PARTICULAR PURPOSE, OR NON-INFRINGEMENT OF THIRD PARTY INTELLECTUAL PROPERTY RIGHTS.

These resources are intended for developers skilled in the art designing with Renesas products. You are solely responsible for (1) selecting the appropriate products for your application, (2) designing, validating, and testing your application, and (3) ensuring your application meets applicable standards, and any other safety, security, or other requirements. These resources are subject to change without notice. Renesas grants you permission to use these resources only for development of an application that uses Renesas products. Other reproduction or use of these resources is strictly prohibited. No license is granted to any other Renesas intellectual property or to any third party intellectual property. Renesas disclaims responsibility for, and you will fully indemnify Renesas and its representatives against, any claims, damages, costs, losses, or liabilities arising out of your use of these resources. Renesas' products are provided only subject to Renesas' Terms and Conditions of Sale or other applicable terms agreed to in writing. No use of any Renesas resources expands or otherwise alters any applicable warranties or warranty disclaimers for these products.

(Rev.1.0 Mar 2020)

Corporate Headquarters

TOYOSU FORESIA, 3-2-24 Toyosu,
Koto-ku, Tokyo 135-0061, Japan
www.renesas.com

Contact Information

For further information on a product, technology, the most up-to-date version of a document, or your nearest sales office, please visit:
www.renesas.com/contact/

Trademarks

Renesas and the Renesas logo are trademarks of Renesas Electronics Corporation. All trademarks and registered trademarks are the property of their respective owners.