

7334L2622F02LF

Catalogue Part Number Key

Lead Free Version (Optional)

Durability
 0: 2500 Mating Cycles
 2: 10000 Mating Cycles
 5: 100000 Mating Cycles

Number of contacts :
 2: 8 contacts ISO
 3: 16 contacts ISO + AFNOR

GENERAL:
 This L26 connector uses a "sliding" contact technology suitable for most applications.
 It has been designed for easy mounting on the PCB.

ELECTRICAL PROPERTIES:
 Insulation resistance : 5000 MΩ min
 Dielectric withstanding : 750 Vrms min
 Current carrying capacity : 10µA min. 1A max
 Contact resistance : 100mΩ max
 Card sensor type : Normally closed

MECHANICAL PROPERTIES:
 Contact Normal force : 0.6 N max (EMV Standard)
 Insertion force : 10 N max
 Extraction force : 1 N min
 Durability : According to UTE C93-421

MATERIAL:
 Housing : Thermoplastic 30 % Glass Filled, Colour Black, Rated UL94V0
 Contacts and switch : Phosphor bronze
 Plating : Nickel all over on contact area
 Gold on contact area.
 Tin/Lead on soldertails
 FOR LEAD FREE PLATING :
 Matte Tin on solder tail in place of Tin/Lead
 Bare edge allowed

ENVIRONMENT:
 Operating temperature: -20°C / +70°C
 Storage temperature: -40°C / +85°C
 Printed Circuit Board thickness : 1.6mm

REFERENCE DOCUMENTS:
 Product specification VGN 11596
 Packaging Specification VGN 11619

A

B

C

D

A

B

C

D

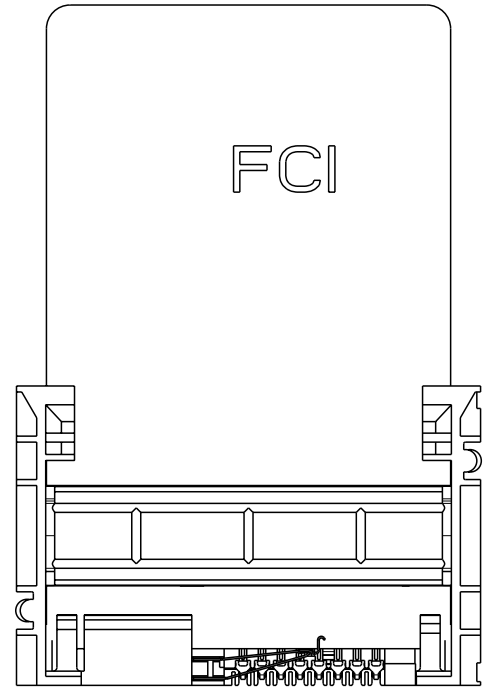

SCALE 1:1

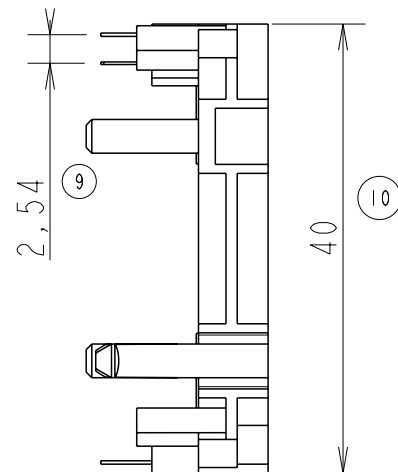
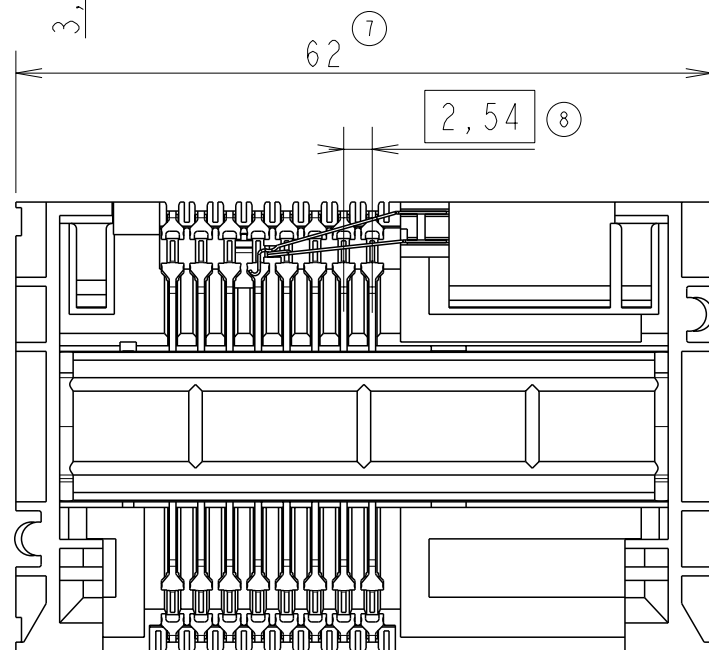
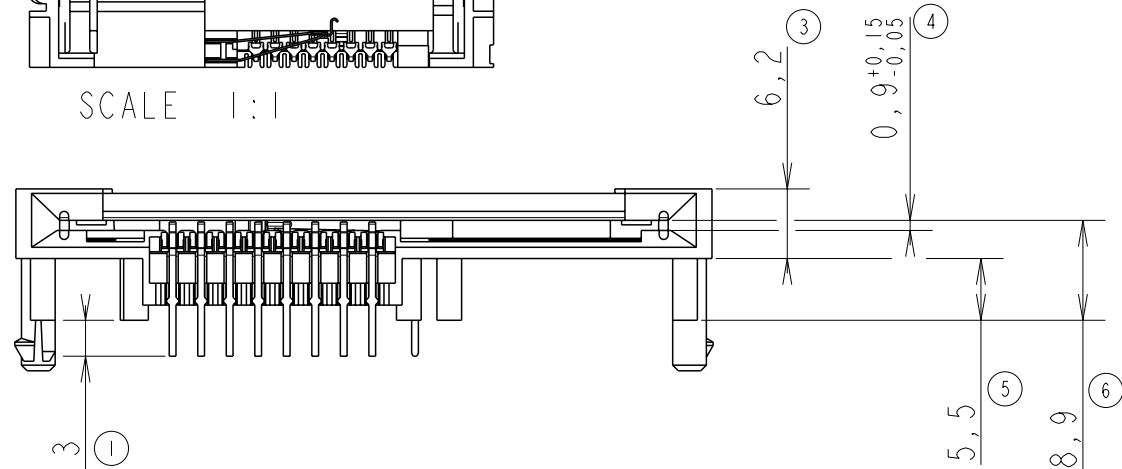

LEAD FREE VERSION:

"This product meets European Union Directives and other country regulations as described in GS-22-008"

The housing will withstand exposure to 260°C peak temperature for 10seconds in a wave solder application with a 1.6mm minimum thick circuit board. Use protective adhesive tape (Kapton or Teflon) or protective metallic devices on the areas which are directly exposed to wave soldering as it is used in classical leaded wave soldering

General Tolerances: ± 0.2 mm

www.fciconnect.com		surface	tolerance std	projection	mm
		ISO 1302 ✓	ISO 406 ISO 1101		
		TOLERANCES UNLESS OTHERWISE SPECIFIED			
Dr	N. TWINCY	2002/04/30	ANGULAR	0.X	±
Eng	F TISSERAND	2002/04/30	LINEAR	0.XX	±
Chr	RAMESH P.K	2009/03/26	0° ±°	0.XXX	±
Appr	S.S.CHERIAN	2009/03/26	Product family		5S2F
				size	A3
				Scale	3:2
				ECN	109-0048
				Spec ref	SEE NOTES
FCi		L26 TYPE F02		dwg no	VJW_54702
		catalog no		SEE TABLE	CUSTOMER
				sheet 1 of 2	Rev. F

rev	ecn no	dr	date
A	F20307	DLE	2002/04/30
B	Is 3053	JTA	2003/05/13
C	105-0071	DTK	2005/06/25
D	106-0084	SSC	2006/06/21
E	106-0189	SSC	2006/10/17
F	109-0048	SSC	2009/03/26
-	-	-	-



RECOMMENDED PCB LAYOUT CONTACT CONFIGURATION : ISO & AFNOR
(CONNECTOR SIDE)

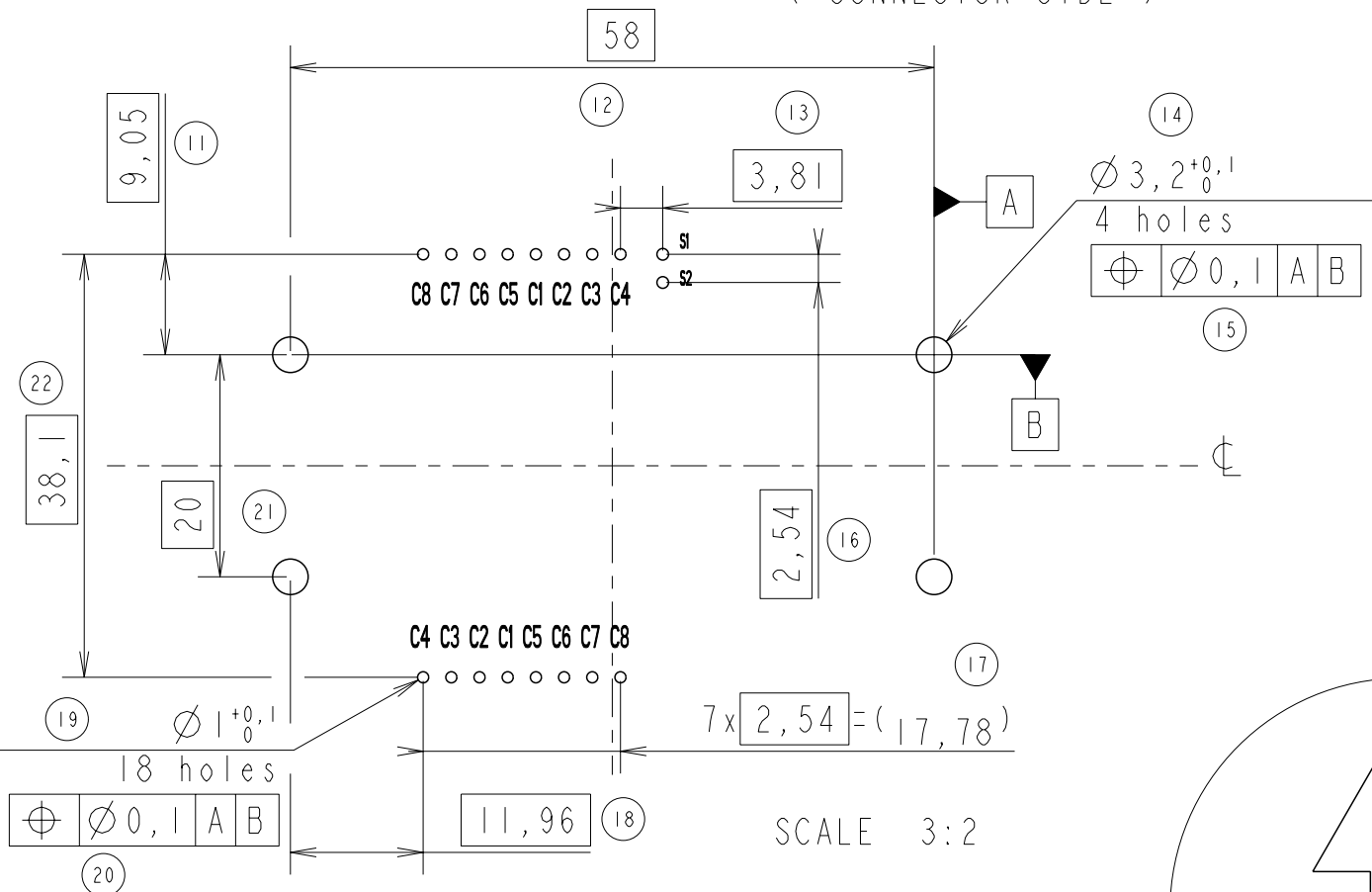

STANDARD LAYOUT FOR 'KEEP OUT ZONE' (Connector Side)

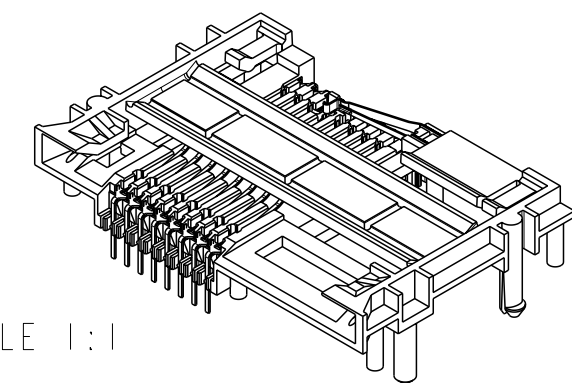
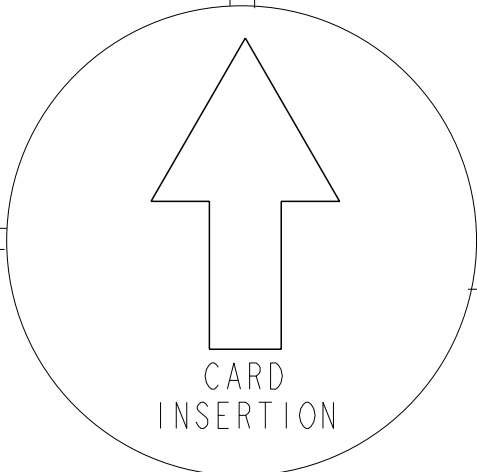
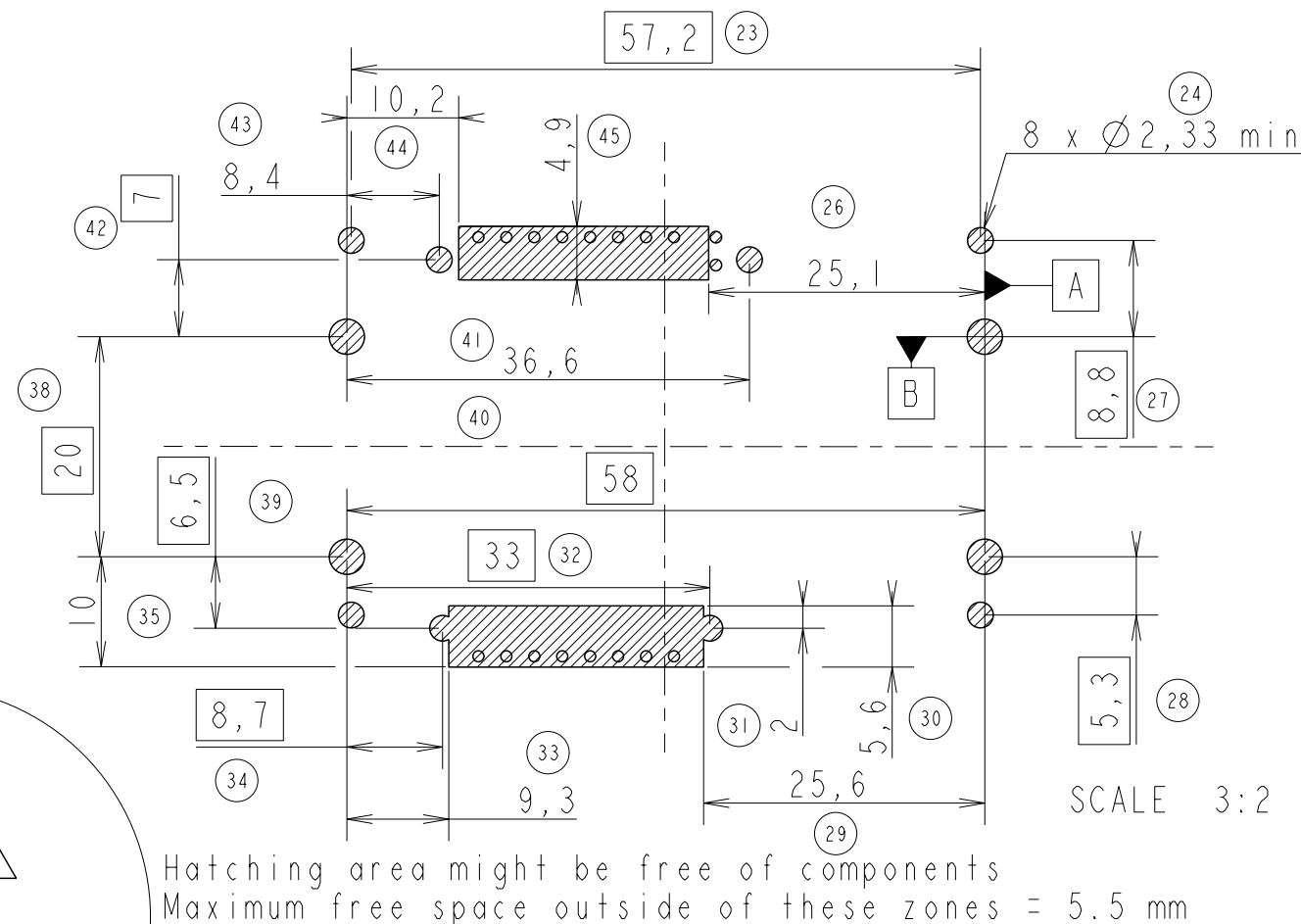

RECOMMENDED PCB LAYOUT CONTACT CONFIGURATION : ISO
(CONNECTOR SIDE)

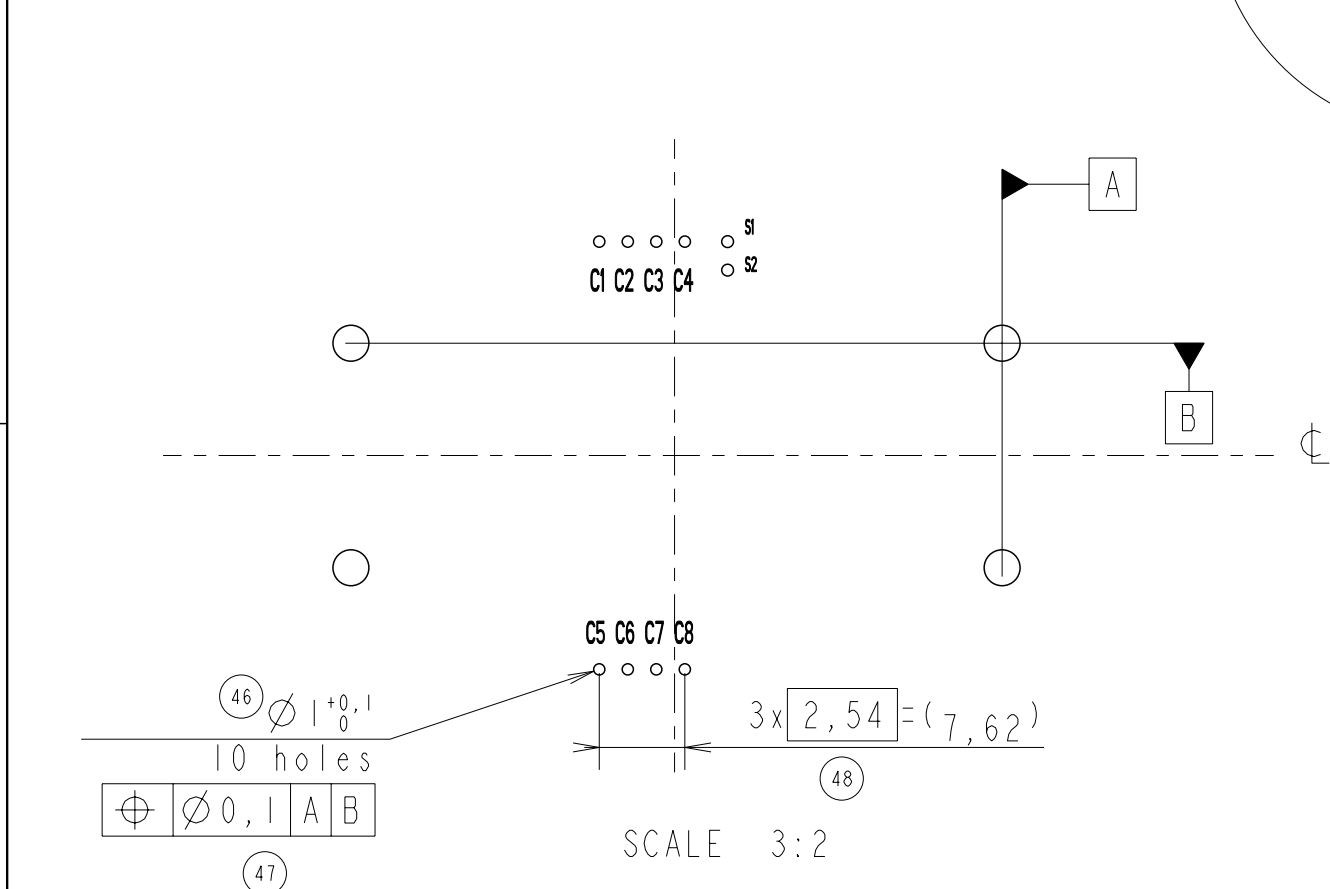

EUROPEAN PROJECTION

www.fciconnect.com		surface - ✓ ISO 1302	tolerance std ISO 406 ISO 1101	projection mm
TOLERANCES UNLESS OTHERWISE SPECIFIED				
Dr	N. TWINCY	2002/04/30	ANGULAR	0.X ±
Eng	F TISSERAND	2002/04/30	LINEAR	0.XX ±
Chr	RAMESH P.K	2009/03/26	0° ±°	0.XXX ±
Appr	S.S.CHERIAN	2009/03/26	Product family	5S2F
FCi		L26 TYPE F02		Rev. F
catalog no		SEE TABLE	CUSTOMER	sheet 2 of 2



Copyright FCI.