

REV.	DATE	DESCRIPTION
NC	01/10/00	INITIAL RELEASE
A	10/01/06	UPDATE DRAWING FORMAT
B	08/03/07	REVISE CABLE DESCRIPTION TO RG-179

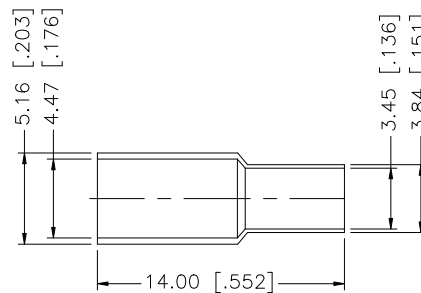
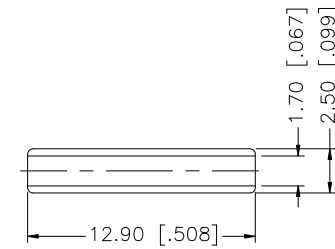
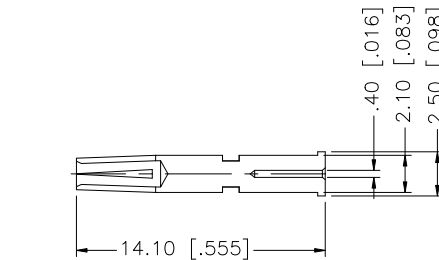
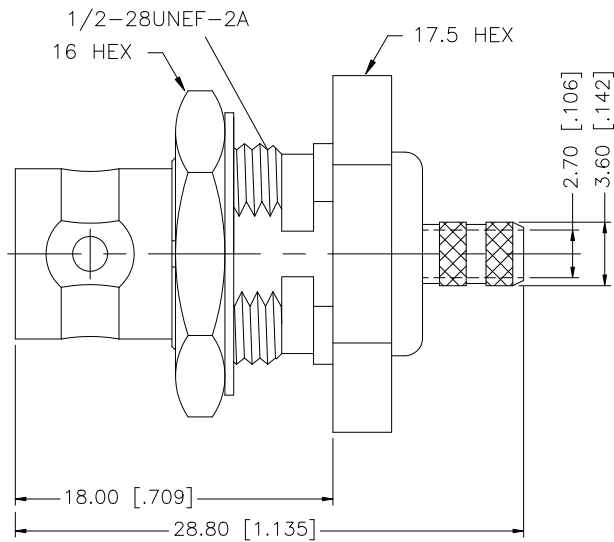
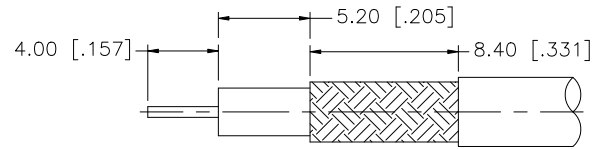
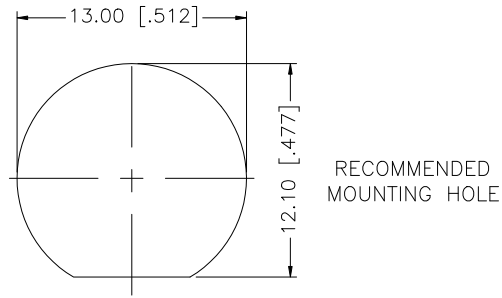

CRIMP NOTES:

1. CRIMPED FERRULE HEX CRIMP SIZE .178"
2. CRIMPED CONTACT PIN HEX CRIMP SIZE .068"

DESCRIPTION	MATERIAL	FINISH	QTY	UNLESS OTHERWISE SPECIFIED DIMENSIONS ARE IN MILLIMETERS. DIMENSIONS IN [] ARE IN INCHES AND FOR CUSTOMER REFERENCE ONLY.	APPROVALS	DATE	Amphenol Connex			
				UNLESS OTHERWISE SPECIFIED TOLERANCES FOR MILLIMETERS ARE: 0.5 - 8mm ± 0.20mm 8 - 30mm ± 0.40mm 30 - 120mm ± 0.50mm	DRAWN G.R.S.	08/03/07	PART DESCRIPTION BNC BULKHEAD CRIMP JACK (FOR RG-179 DOUBLE BRAID CABLE)			
				UNLESS OTHERWISE SPECIFIED TOLERANCES FOR INCHES ARE: .020 - .315 ± 0.007" .315 - 1.180 ± 0.015" 1.180 - 4.724 ± 0.020"	CHECKED					
					ISSUED		DWG. NO. 112648.DWG			
					SHEET 1 OF 1					
					CAD FILE C:/112/112648.DWG		SCALE A			
				DO NOT SCALE DRAWING						