

REVISED		REVISIONS			
NO.	DATE	DESCRIPTION	DATE	BY	APP'D
B	REVISED PER ECO-12-011893		27JUN12	KH	PO

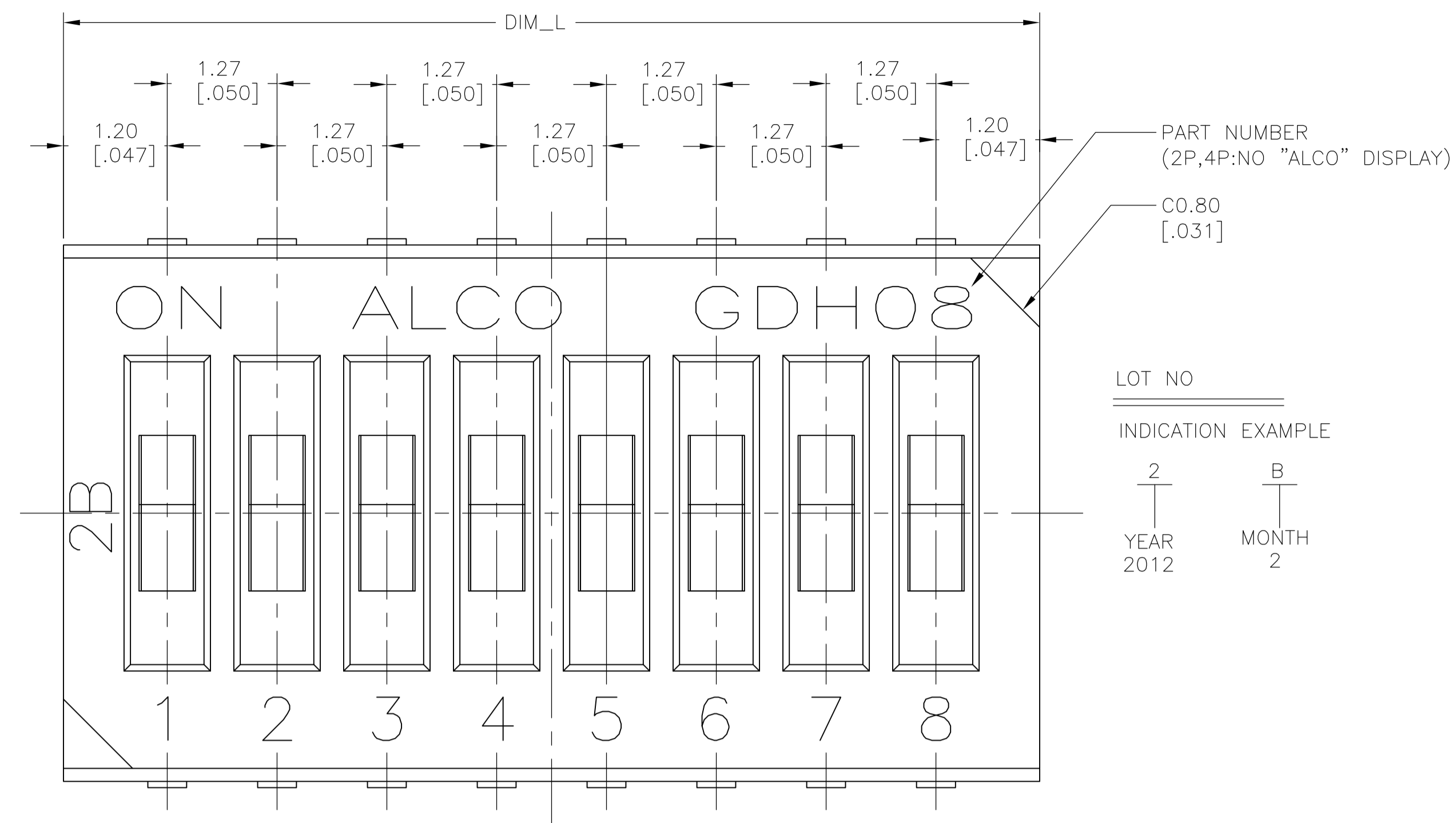

PART NUMBER
(2P,4P:NO "ALCO" DISPLAY)

0.80
[.031]

LOT NO _____

INDICATION EXAMPLE

2 B

YEAR MONTH

2012 2

SPECIFICATIONS:

MATERIALS:
CASE-PPS UL94V-0, BLACK
COVER-PPS UL94V-0, BLACK
ACTUATOR-LCP UL94V-0, WHITE
FIXED CONTACT-COPPER ALLOY, GOLD OVER NICKEL PLATE
MOVING CONTACT-COPPER ALLOY, GOLD OVER NICKEL PLATE
TERMINAL-COPPER ALLOY, GOLD OVER NICKEL PLATE
TAPE SEAL-POLYIMIDE FILM

ELECTRICAL:
CONTACT RATING: NON-SWITCHING: 100 MILLIAMPS @50VDC
SWITCHING: 25 MILLIAMPS @24 VDC
INITIAL CONTACT RESISTANCE: 100 MILLIOHMS MAX. @2VDC, 10mA.
CONTACT RESISTANCE(AFTER TESTS): 300MILLIOHMS MAX.@2VDC.10mA,
INSULATION RESISTANCE: 100 MEGOHMS MIN @100VDC
DIELECTRIC STRENGTH: 300 VAC, 1MINUTE.
LIFE EXPECTANCY: 1000 CYCLES MIN.

MECHANICAL:
ACTUATION FORCE: 4.94(490gf) MAX.

ENVIRONMENTAL:
OPERATING TEMPERATURE: -30°C TO +85°
STORAGE TEMPERATURE: -45°C TO +100°C
SOLDER HEAT RESISTANCE PER 109-201, CONDITION B SWITCH IN OFF POSITION
SOLDER ABILITY PER JIS C 0050 & JIS C 0053.

- NOTES:**
- SUPPLIED WITH TAPE SEAL STANDARD
 - SWITCH IS TO HAVE OVERALL HEIGHT AS SHOWN
 - ALL MATERIALS AND FINISHES SHALL COMPLY WITH EU DIRECTIVE 2002/95/EC OF 27JAN2003 (ROHS)
 - SUPPLIED PACKAGED IN A TUBE.

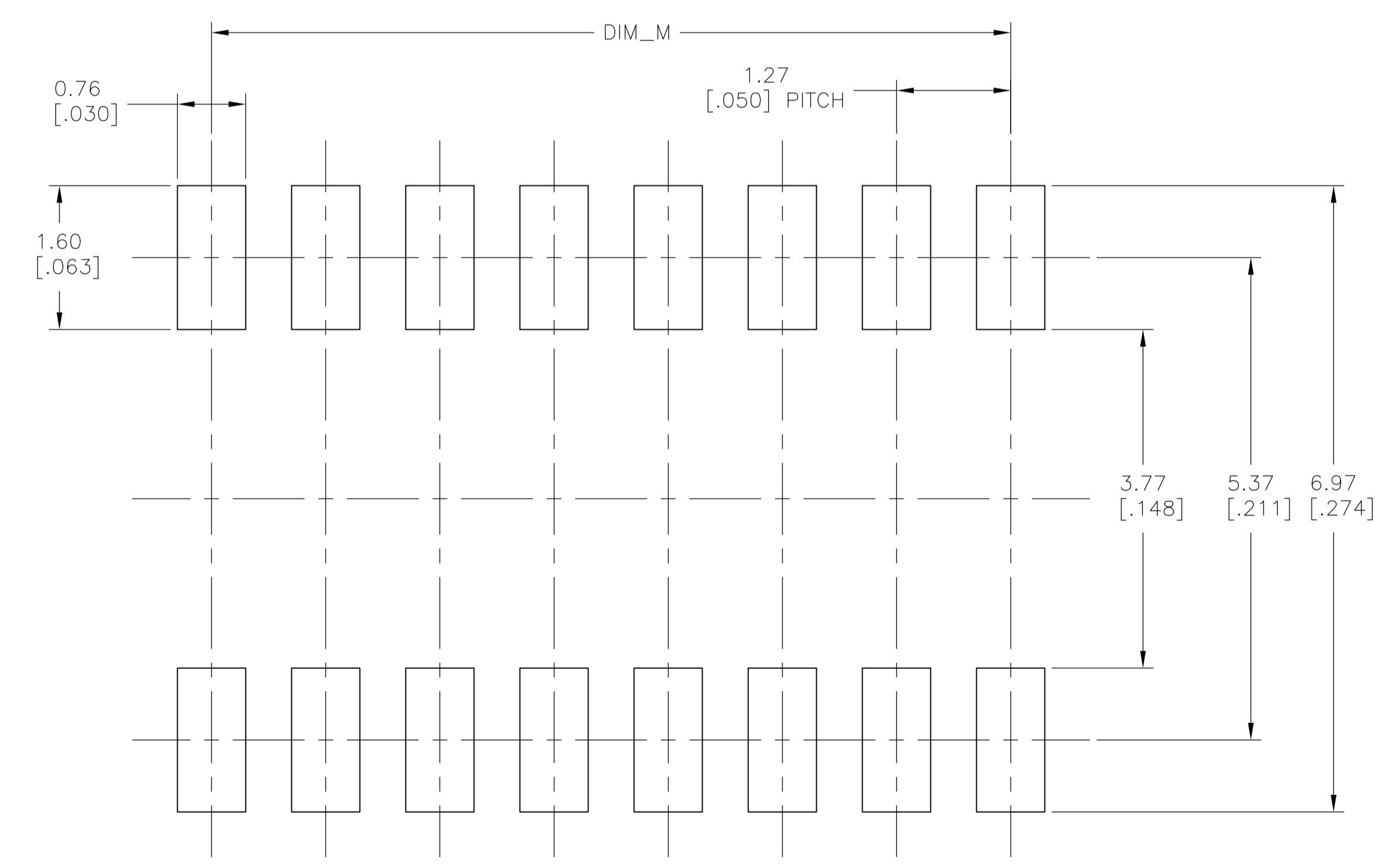
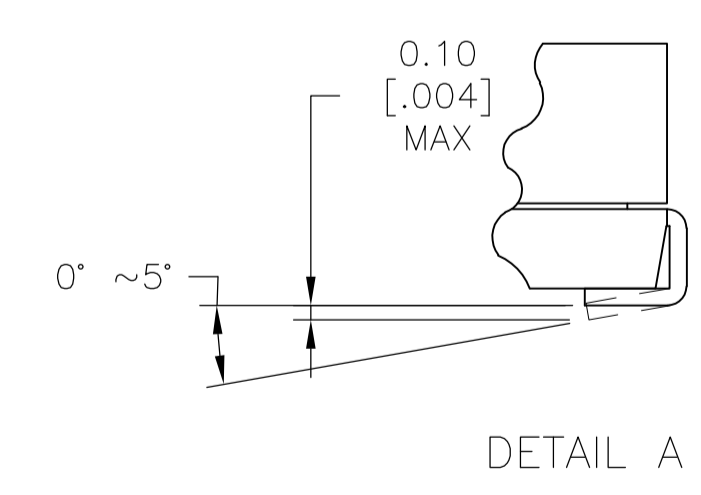
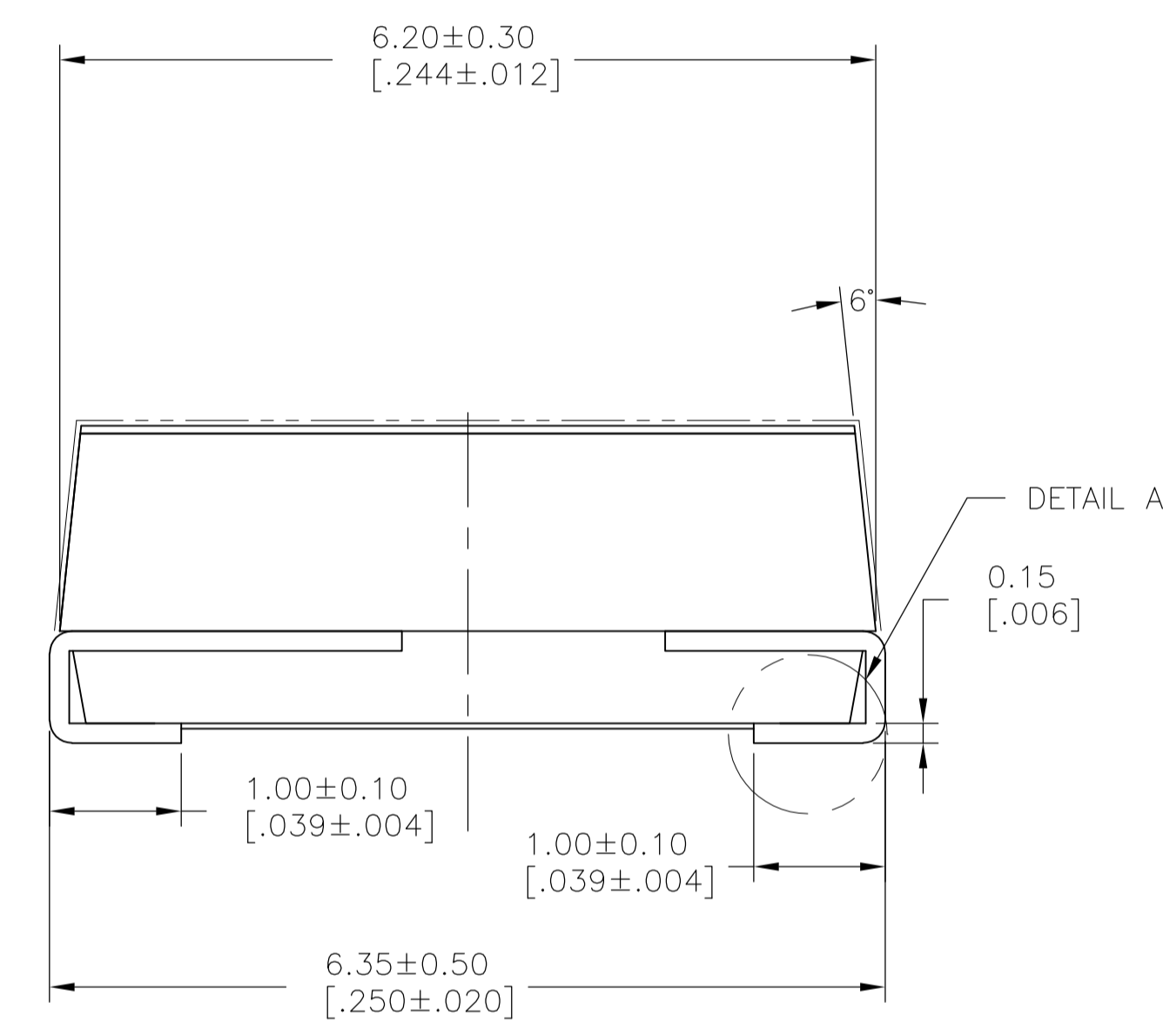
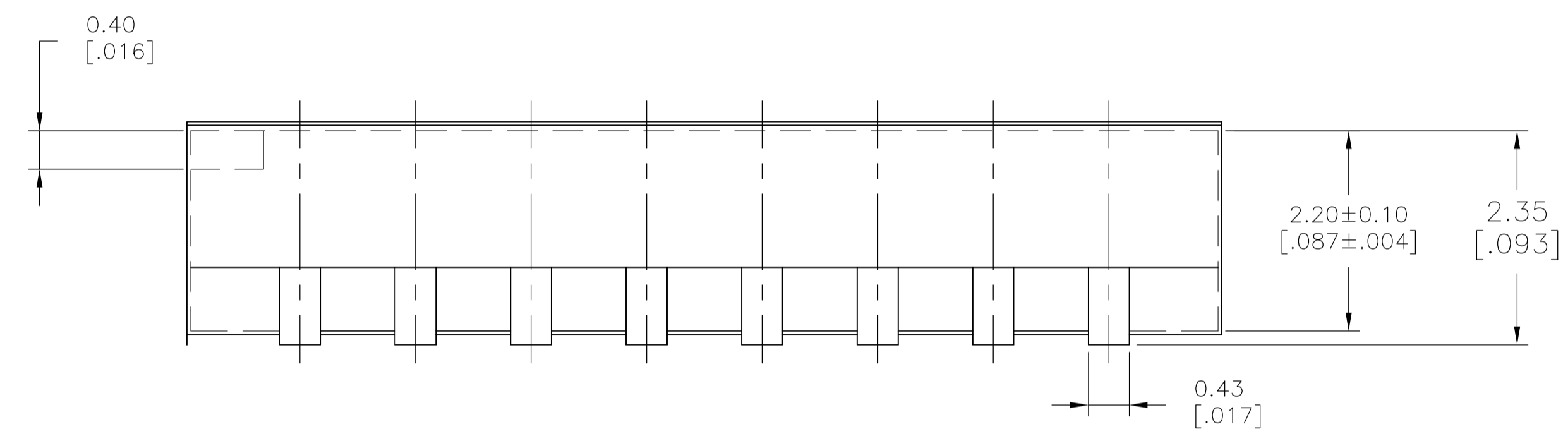

MOUNTING PAD DIMENSIONS(5/1)

POS	DIM M	DIM L	ALCO DISCRPTION	TE P/N
10	11.43[.450]	13.83[.544]	GDH10SA04	1977830-5
8	8.89[.350]	11.29[.444]	GDH08SA04	1977830-4
6	6.35[.250]	8.75[.344]	GDH06SA04	1977830-3
4	3.81[.150]	6.21[.244]	GDH04SA04	1977830-2
2	1.27[.05]	3.67[.144]	GDH02SA04	1977830-1
POS	DIM M	DIM L ±0.50[.020]	ALCO DISCRPTION	TE P/N

THIS DRAWING IS A CONTROLLED DOCUMENT.

DIMENSIONS: mm [INCHES]

TOLERANCES UNLESS OTHERWISE SPECIFIED:

0 PLC	±	-
1 PLC	±	-
2 PLC	±	-
3 PLC	±	0.40[.016]
4 PLC	±	-
ANGLES	±	-

MATERIAL: - FINISH: -

WEIGHT: -

CUSTOMER DRAWING

DIN: KIRAN HOLAL 30MAR2012
CHK: OTT.PETER 30MAR2012
APP'D: OTT.PETER 30MAR2012
NAME: OTT.PETER
PRODUCT SPEC: -
APPLICATION SPEC: -
SIZE: A1
CAGE CODE: 00779
DRAWING NO: 1977830
RESTRICTED TO: -

SCALE: 20:1 SHEET: 1 OF 1 REV: B