

REVISIONS				
P	LTN	DESCRIPTION	DATE	APVD
A		FIRST RELEASE	19AUG2019	SZ SZ
A1		ECO-19-016042	21OCT2019	SZ SZ
A2		ECO-19-017633	07NOV2019	SZ SZ

NOTES, UNLESS OTHERWISE SPECIFIED
 1. MATERIAL:
 HOUSING - THERMOPLASTIC, GLASS PREINFORCED, COLOR, BLACK, UL 94V-0
 CONTACTS- COPPER ALLOY.
 2. FINISH:
 MATING AREA - NOBLE METAL OVERALL NICKEL.
 SOLDER TAIL - MATTE TIN OVERALL NICKEL.
 3. MARK P/N AND DATA CODE IN APPROX. AREA AS SHOWN.
 4. NOT RELEASED
 5. PICK AND PLACE TAPE

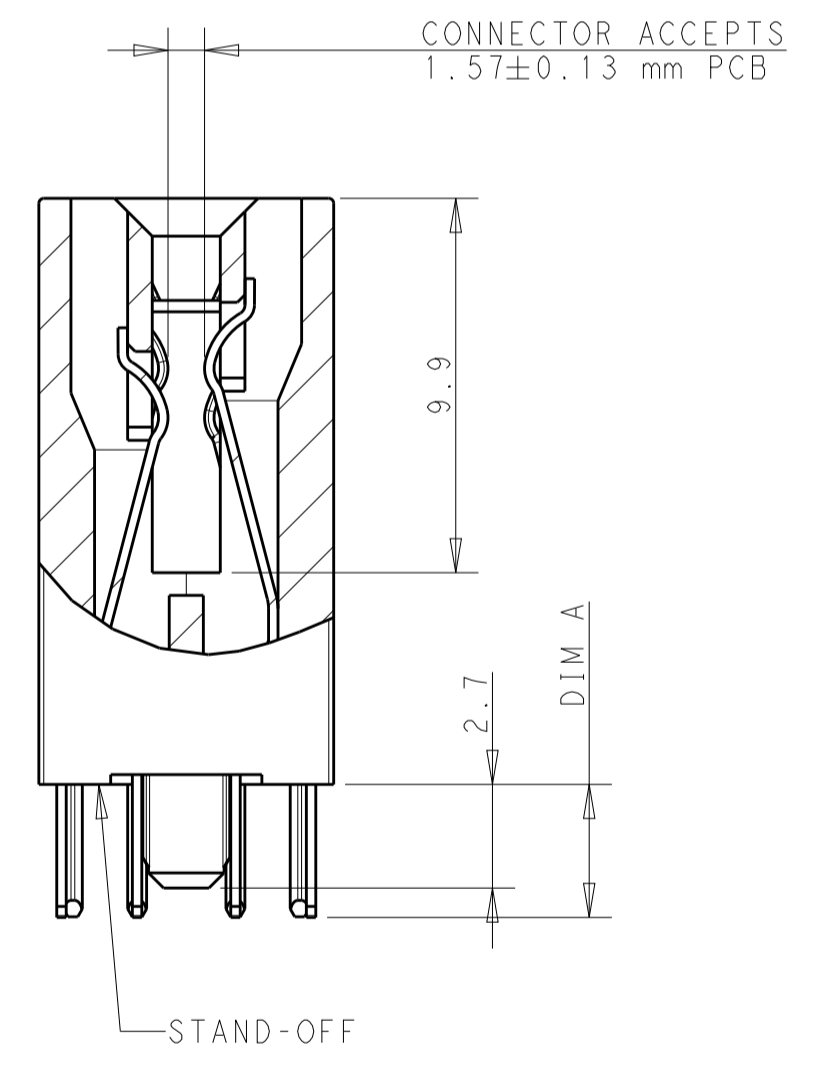

SECTION S-S

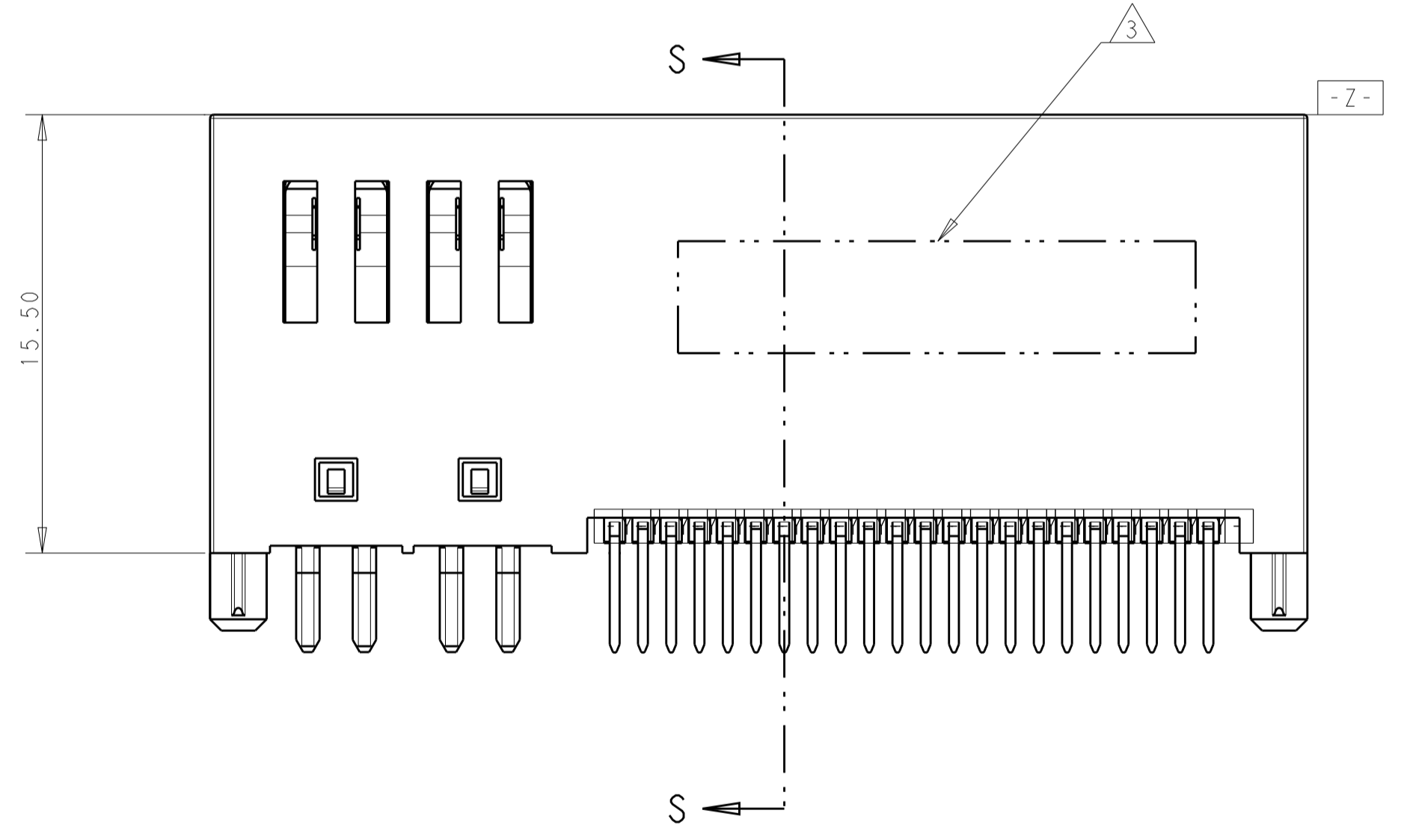
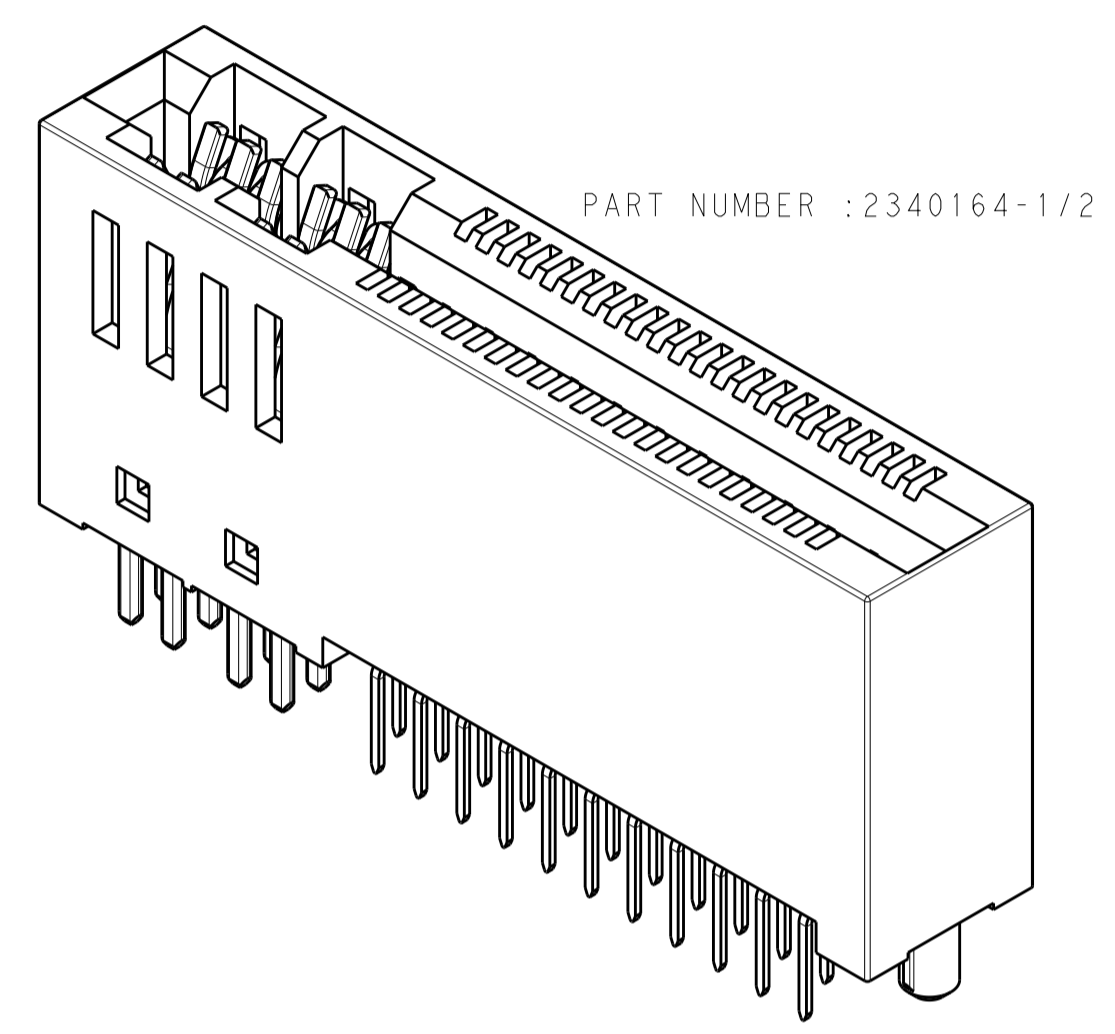
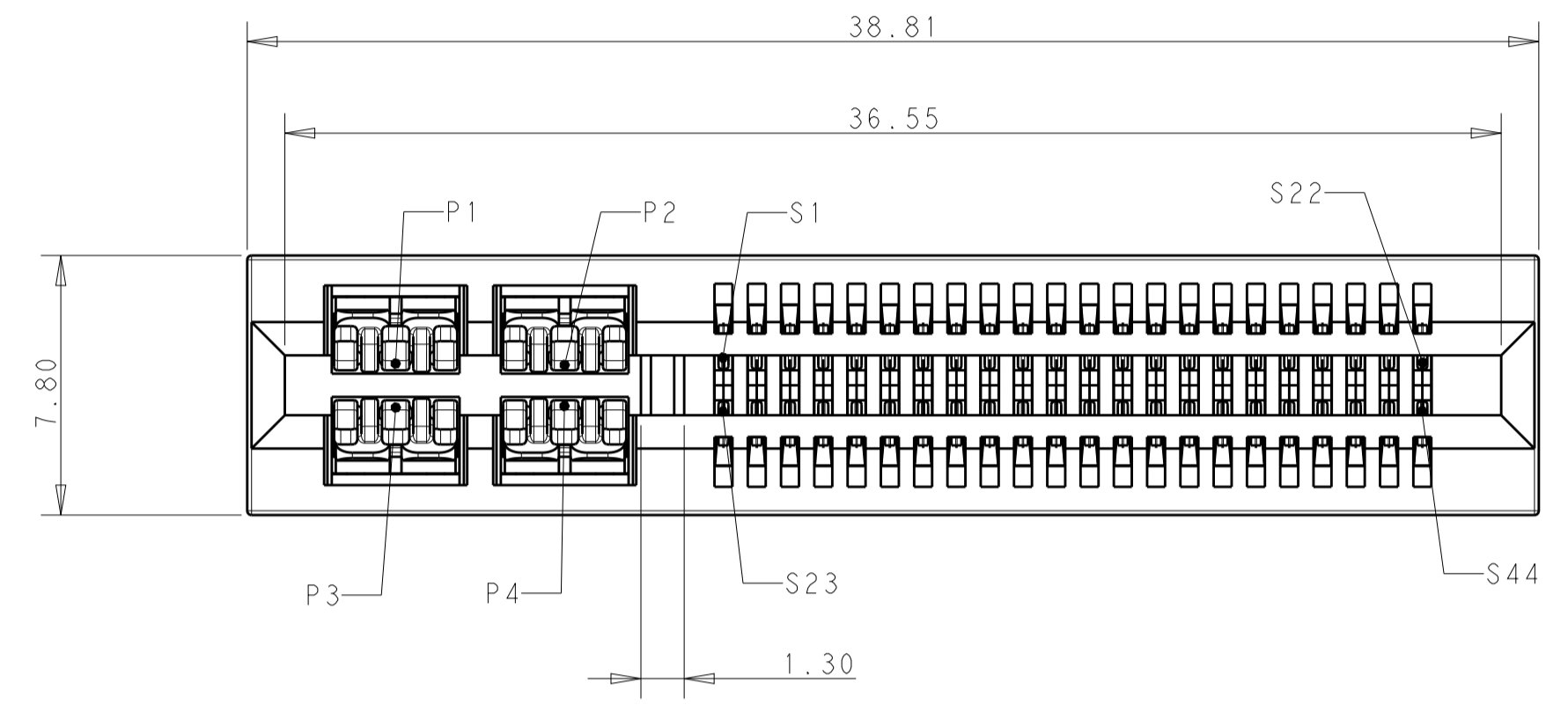
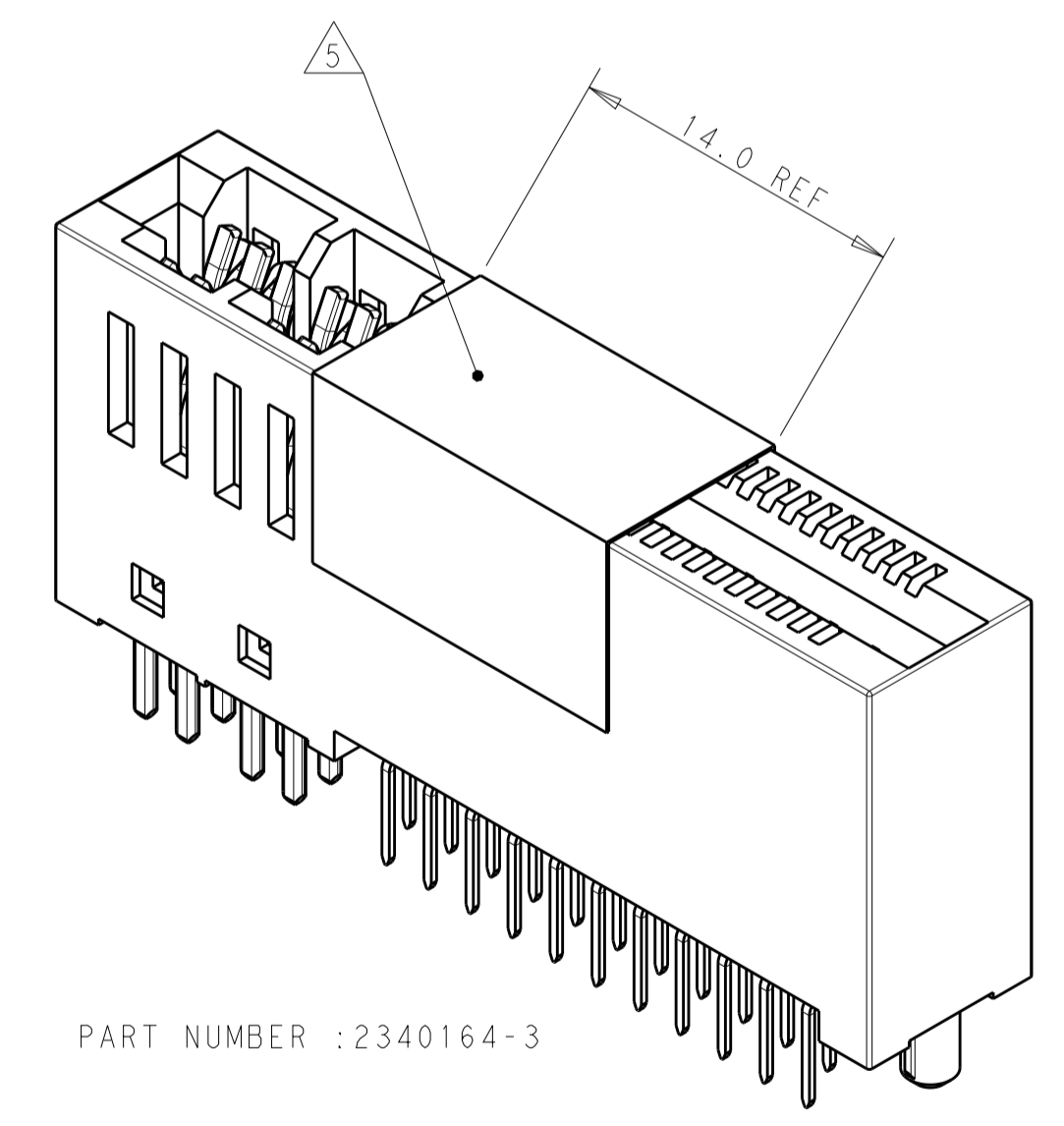

PART NUMBER : 2340164-3

SCALE 4:1

TAPE & REEL	YES	2.90 ± 0.25	2340164-3
HARD TRAY	NO	2.90 ± 0.25	2340164-2
HARD TRAY	NO	3.50 ± 0.25	2340164-1
PACKAGE TYPE	PICK AND PLACE TAPE 5	DIM A	PART NUMBER

THIS DRAWING IS A CONTROLLED DOCUMENT.		OWN: SEAN ZHANG 26JUL2018	TE Connectivity
DIMENSIONS: mm		CHK: SUNY ZHAO 26JUL2018	
TOLERANCES UNLESS OTHERWISE SPECIFIED:		APVD: SUNY ZHAO 26JUL2018	NAME: HD PLUS, CARD EDGE VERTICAL, TH
0 PLC	±	PRODUCT SPEC	108-128091
2 PLC	±0.50	APPLICATION SPEC	
3 PLC	±0.25		
4 PLC	±		
ANGLES	±		
MATERIAL		FINISH	
CUSTOMER DRAWING		WEIGHT	
SCALE 4:1		SHEET 1 OF 2	REV A2

REVISIONS				
P.	LTN	DESCRIPTION	DATE	APVD
		SEE SHEET 1		

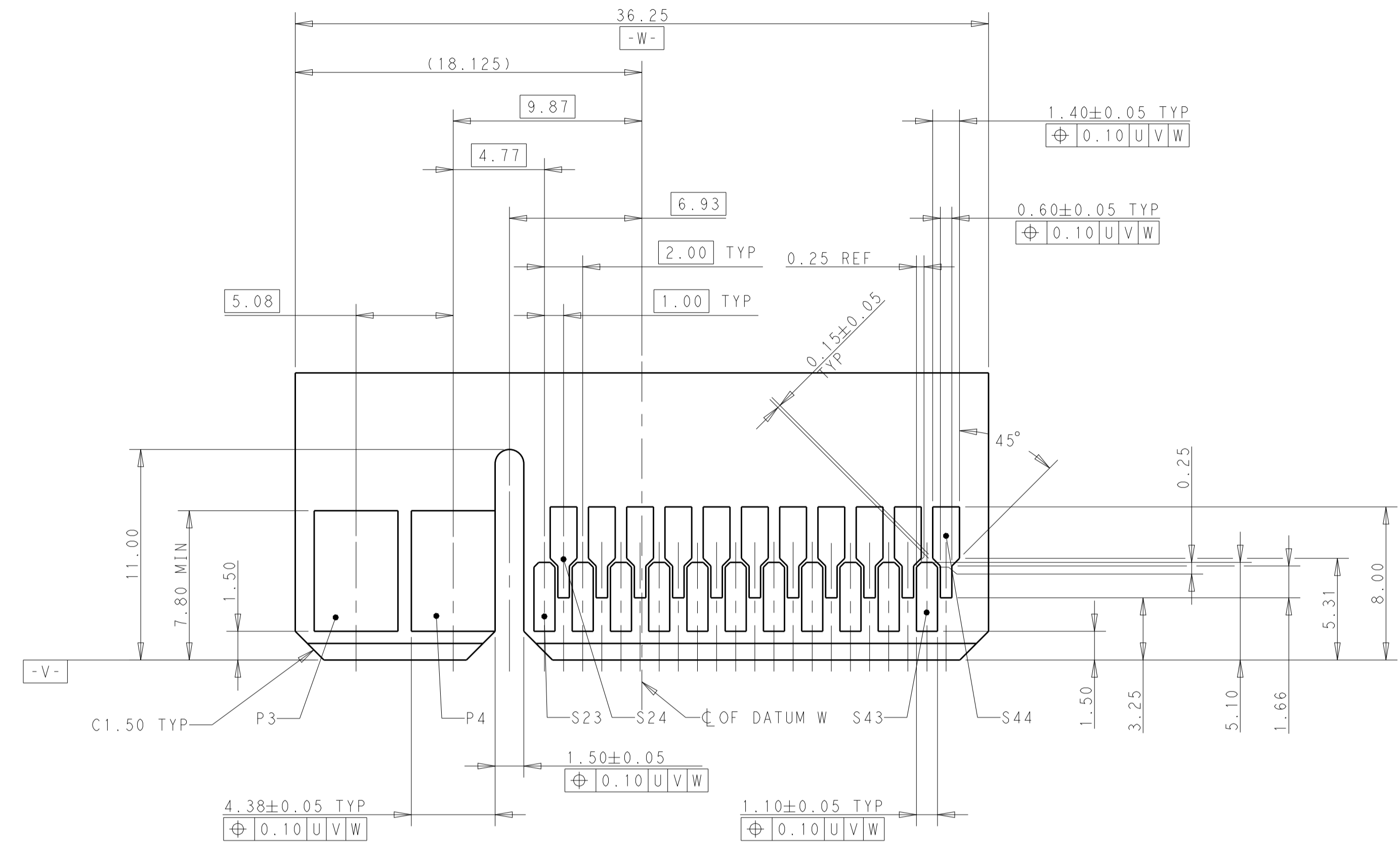

RECOMMENDED MATING BOARD EDGE CONFIGURATION (PRIMARY SIDE SHOWN)

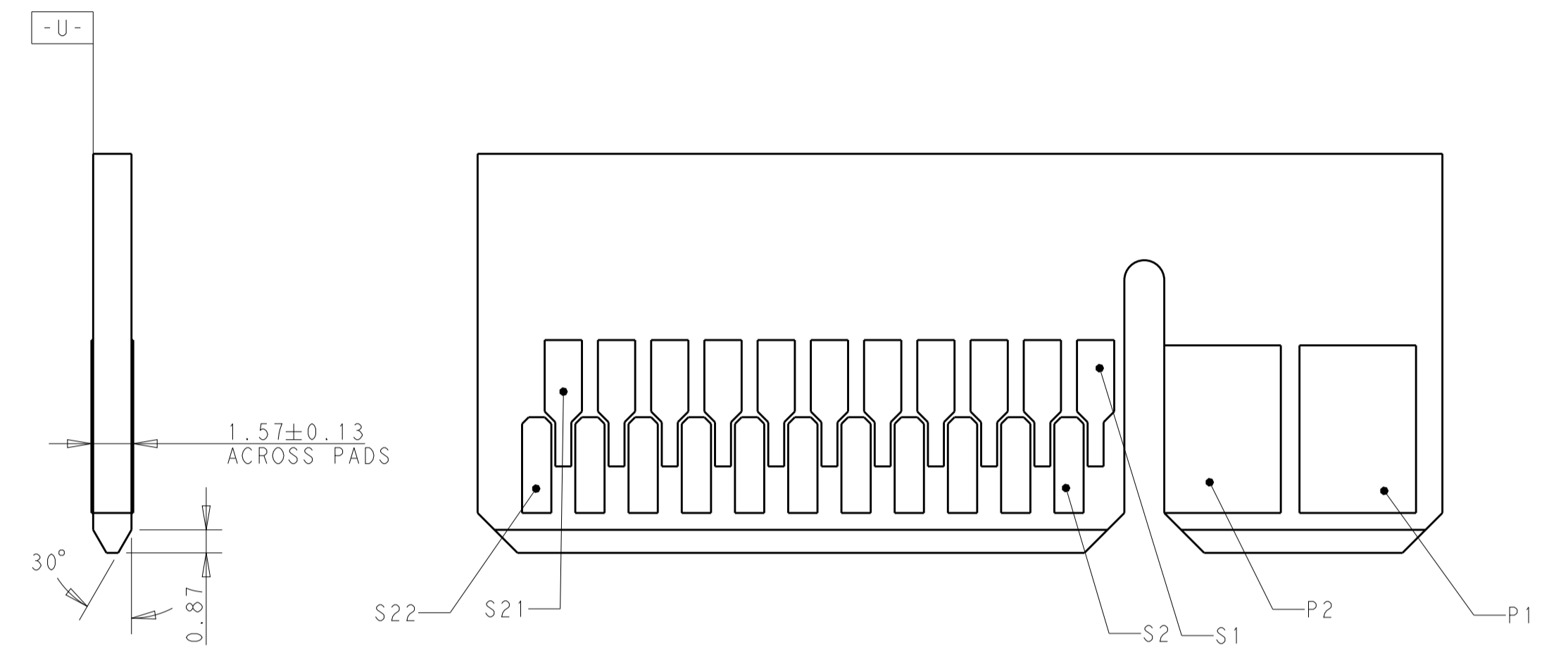

RECOMMENDED MATING BOARD EDGE CONFIGURATION (SECONDARY SIDE SHOWN)

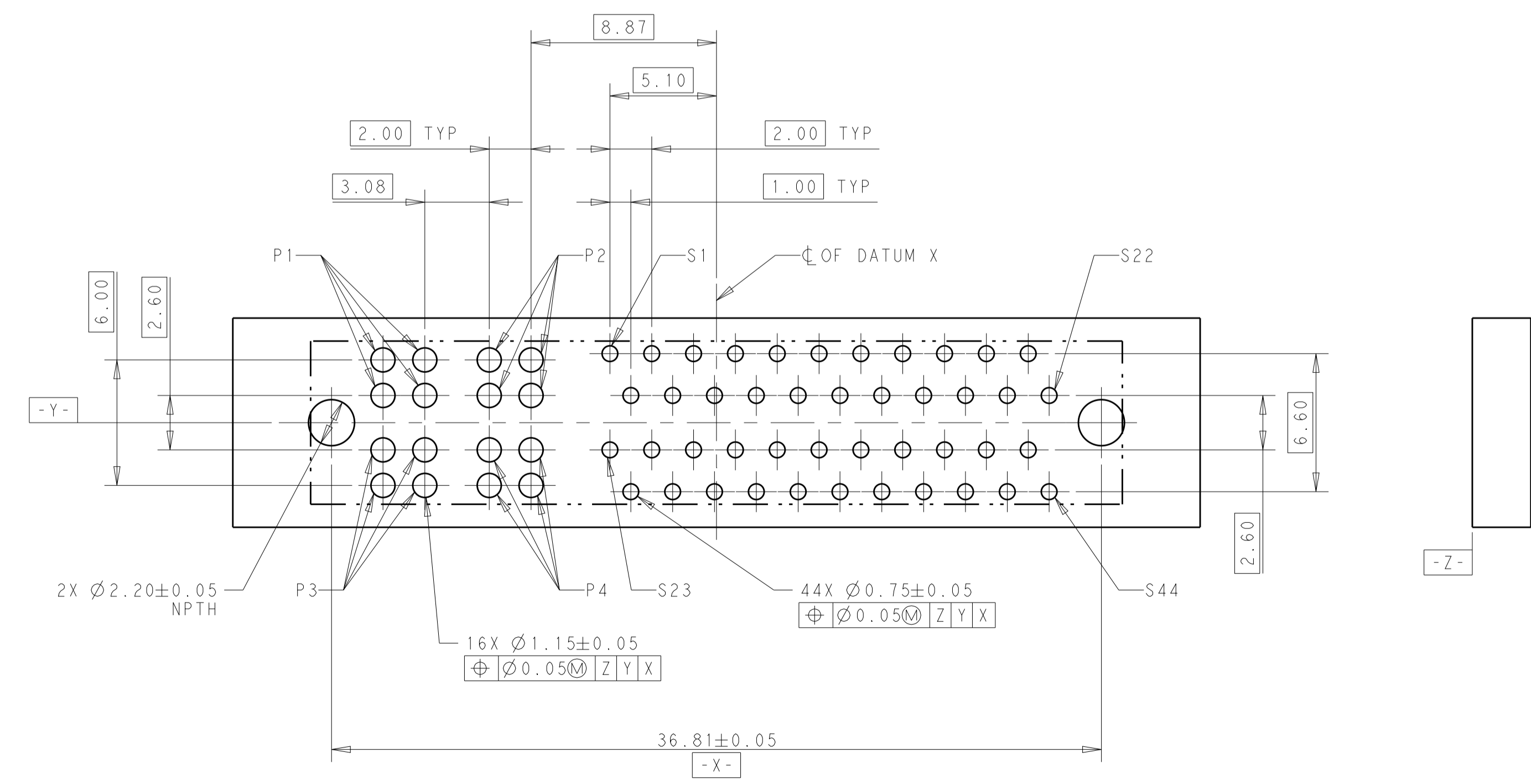

RECOMMENDED MOUNTING BOARD CONFIGURATION LAYOUT VIEW FROM COMPONENT SIDE

- NOTES FOR MOUNTING BOARD, UNLESS OTHERWISE SPECIFIED:
1. PLATED THROUGH HOLE, SIGNAL:
FINISHED HOLE SIZE: 0.75mm.
DRILL HOLE SIZE: 0.85±0.025mm.
 2. PLATED THROUGH HOLE, POWER:
FINISHED HOLE SIZE: 1.15mm.
DRILL HOLE SIZE: 1.25±0.025mm.
 3. COPPER PLATING THICKNESS: 0.025~0.05mm.
 4. SURFACE FINISH: OSP OR IMMERSION TIN PLATING IS RECOMMENDED.

THIS DRAWING IS A CONTROLLED DOCUMENT.		OWN: SEAN ZHANG 26 JUL 2018	TE Connectivity
DIMENSIONS: mm		CHK: -	
TOLERANCES UNLESS OTHERWISE SPECIFIED: 0 PLC ± 1 PLC ±0.20 2 PLC ±0.10 3 PLC ± 4 PLC ± ANGLES ±2°		APVD: -	NAME: HD PLUS, CARD EDGE VERTICAL, TH
MATERIAL: -		PRODUCT SPEC: -	RESTRICTED TO: -
FINISH: -		APPLICATION SPEC: -	SIZE: A1
CUSTOMER DRAWING		WEIGHT: -	CAGE CODE: 2340164
SCALE: 5:1		SHEET: 2 OF 2	REV: A2