

THIS COPY IS PROVIDED ON A RESTRICTED BASIS AND IS NOT TO BE USED IN ANY WAY DETRIMENTAL TO THE INTERESTS OF PANDUIT CORP.

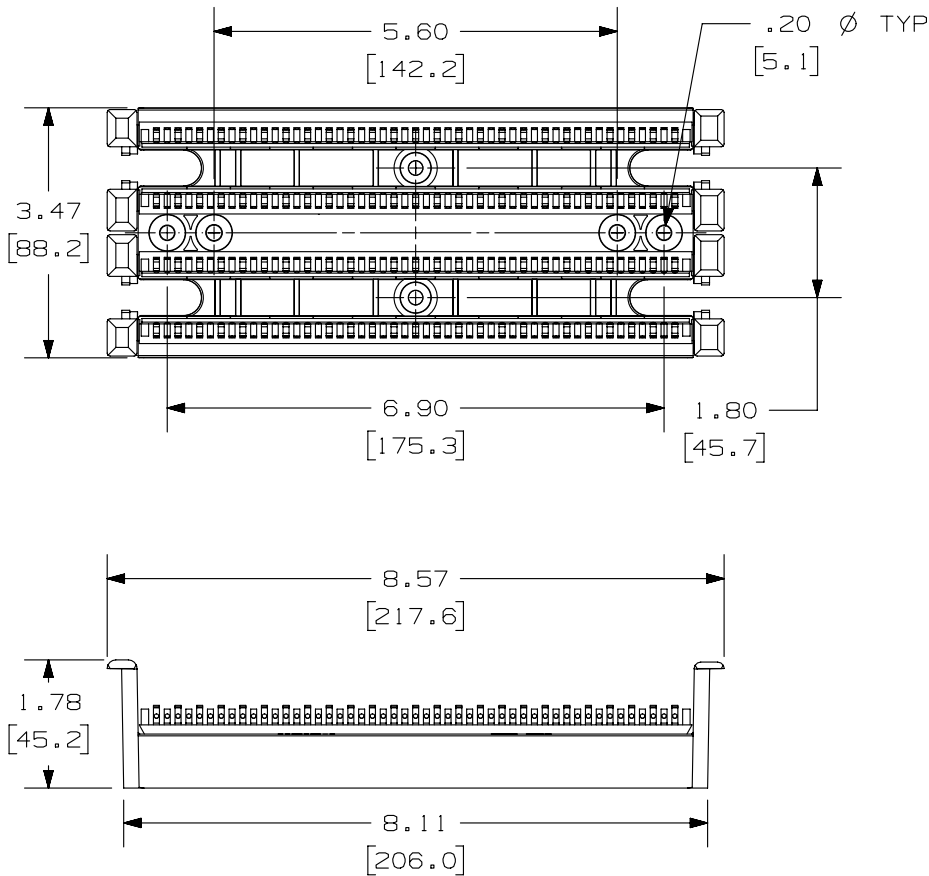

PANDUIT PART NO.	WEIGHT
P110B100-X	.420 LB/EACH 190 g/EACH

NOTE:

- DIMENSIONS ARE NOMINAL UNLESS OTHERWISE SPECIFIED.
- TOOTH GEOMETRY IN WIRE SEPARATOR SIMPLIFIED FOR DWG CLARITY.
- WIRE SEPERATOR TEETH MARKED ACCORDING TO 25-PAIR TIP COLOR SCHEME.
- APPEARING ON TOP SURFACE: "PANDUIT", PART#, AND QC#.
- DIMINSIONS IN [] ARE IN METRIC UNITS.

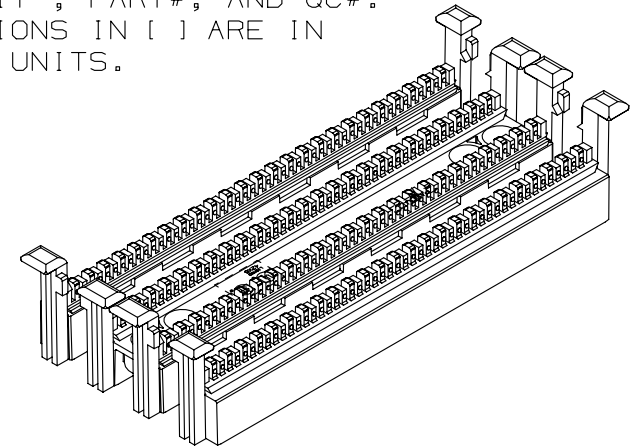

PART NUMBER		P110B100-X	
TITLE			
PAN-PUNCH 110 PUNCH DOWN SYSTEM 100 PAIR BASE		WITHOUT LEGS	
CUSTOMER DRAWING			
ITEM REVISION NAME		B50000LH/07	
DATASET FILE NAME		B50000LH_DC/07B	
UNLESS OTHERWISE SPECIFIED, DIMENSIONAL TOLERANCES ARE: IN [mm]		MATERIAL:	
.x \pm		.xxx \pm .010 [.3]	
.xx \pm .03 [.8]		ANGLES \pm	
THIRD ANGLE PROJECTION		DRAWING NUMBER:	
DRAWN BY		KA-10492	
DATE		SHT 1 OF 1	
2-5-97		A	
CHK		SCALE	
CAF		NONE	

REV	DATE	BY	CHK	APR	DESCRIPTION	ECN
1	5/20/14	JSP	REFR	MMR	A. REVISED DRAWING TITLE BLOCK.	KA-10492
R	2-5-97	BAP	CAF	CAF	RELEASED TO PRODUCTION	KA-10492

D10100DA/14